

# **NISSAN R34**

# **SERVICE MANUAL**

## QUICK REFERENCE INDEX

GENERAL INFORMATION _____	GI
ENGINE CONTROL SYSTEM _____	EC
AUTOMATIC TRANSMISSION _____	AT
BRAKE SYSTEM _____	BR
STEERING SYSTEM _____	ST
RESTRAINT SYSTEM _____	RS
HEATER & AIR CONDITIONER _____	HA
ELECTRICAL SYSTEM _____	EL
SERVICE DATA _____	SD

# NISSAN

MODEL R34 SERIES

## FOREWORD

This Service Manual contains information concerning necessary service procedures and relevant data for the model R34 series.

All information, illustrations and specifications contained in this Service Manual are based on the latest product information available at the time of publication. If your NISSAN model differs from the specifications contained in this Service Manual, consult your NISSAN distributor for information.

The right is reserved to make changes in specifications and methods at any time without notice.

© 1998 NISSAN MOTOR CO., LTD. Printed in Japan

All rights reserved. No part of this Service Manual may be reproduced or stored in a retrieval system, or transmitted in any form, or by any means, electronic, mechanical, photocopying, recording or otherwise, without the prior written permission of Nissan Motor Company Ltd., Tokyo, Japan.

8E-OR34JO

www.rss-gtr.org

# HOW TO USE THIS MANUAL

- ▶ This Service Manual only contains the service data specifications and trouble diagnosis information such as self-diagnosis, CONSULT, circuit diagram and so on.
- ▶ For other information not specified in this manual, refer to Japanese version Service Manual (Pub. No. A006029) and wiring diagram manual (Pub. No. WD8E0R34J0).

## IMPORTANT SAFETY NOTICE

The proper performance of service is essential for both the safety of the technician and the efficient functioning of the vehicle.

The service methods in this Service Manual are described in such a manner that the service may be performed safely and accurately.

Service varies with the procedures used, the skills of the technician and the tools and parts available. Accordingly, anyone using service procedures, tools or parts which are not specifically recommended by NISSAN must first be completely satisfied that neither personal safety nor the vehicle's safety will be jeopardized by the service method selected.

# GENERAL INFORMATION

## SECTION **GI**

GI

EC

AT

BR

ST

RS

HA

EL

SD

## CONTENTS

<b>CONSULT CHECKING SYSTEM</b> .....	2	<b>IDENTIFICATION INFORMATION</b> .....	3
Function and System Application .....	2	Model Variation .....	3
Lithium Battery Replacement .....	2	Vehicle Identification Number .....	4
Checking Equipment .....	2	Vehicle Identification Plate .....	4

# CONSULT CHECKING SYSTEM

## Function and System Application

Diagnostic test mode	Function	ENGINE	A/T	Air bag	ABS
Work support	This mode enables a technician to adjust some devices faster and more accurately by following the indications on CONSULT.	×	—	—	—
Self-diagnostic results	Self-diagnostic results can be read and erased quickly.	×	×	×	×
Trouble diagnostic record	Current self-diagnostic results and all trouble diagnostic records previously stored can be read.	—	—	×	—
ECU discriminated No.	Classification number of a replacement ECU can be read to prevent an incorrect ECU from being installed.	—	—	×	—
Data monitor	Input/Output data in the ECM can be read.	×	×	—	×
Active test	Diagnostic Test Mode in which CONSULT drives some actuators apart from the ECMs and also shifts some parameters in a specified range.	×	—	—	×
ECM part number	ECM part number can be read.	×	×	—	×
Function test	Conducted by CONSULT instead of a technician to determine whether each system is "OK" or "NG".	×	—	—	—

x: Applicable

## Lithium Battery Replacement

CONSULT contains a lithium battery. When replacing the battery obey the following:

**WARNING:**

Replace the lithium battery with SANYO Electric Co., Ltd., CR2032 only. Use of another battery may present a risk of fire or explosion. The battery may present a fire or chemical burn hazard if mistreated. Do not recharge, disassemble or dispose of in fire.

Keep the battery out of reach of children and discard used battery conforming to the local regulations.

## Checking Equipment

When ordering the below equipment, contact your NISSAN distributor.

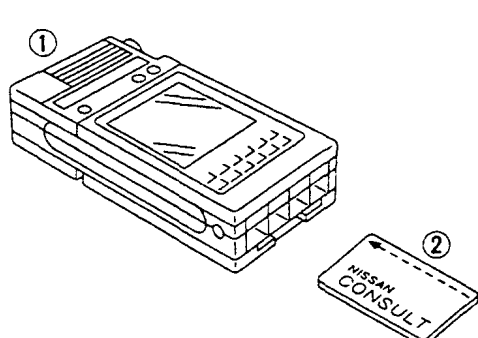
Tool name	Description
<b>NISSAN CONSULT</b> ① CONSULT unit and accessories ② Program card UE990: For Automatic transmission of Dual matic M-ATx EE980: Except for Automatic transmission of Dual matic M-Atx	 <p>NT004</p>

# IDENTIFICATION INFORMATION

## Model Variation

Body	Grade	Model	Engine	Transmission	Rear differential carrier
		RH drive			
2-door	25GT TURBO	GGKBRTFR34UDA	RB25DET	FS5R30A	R200V
		GGKBRTAR34UDA		RE4R01B	
4-door	25GT-X	BGKAREFR34EDA	RB25DE	FS5W71C	R200
		BGKAREAR34EDA		RE4R01B	
2-door	20GT	GGHAREFR34EDA	RB20DE	FS5W71C	R200
		GGHAREAR34EDA		RE4R01B	
	25GT	GGKAREFR34EDA	RB25DE	FS5W71C	
		GGKAREAR34EDA		RE4R01B	
	25GT TURBO	GGKBRTFR34UDA	RB25DET	FS5R30A	
		GGKBRTAR34UDA		RE4R01B	
4-door	20GT	BGHAREFR34EDA	RB20DE	FS5W71C	R200
		BGHAREAR34EDA		RE4R01B	
	25GT	BGKAREAR34EDA	RB25DE	RE4R01B	
		BGKBRTFR34UDA		RB25DET	
	25GT TURBO	BGKBRTAR34UDA	RE4R01B		

### Prefix and suffix designations:

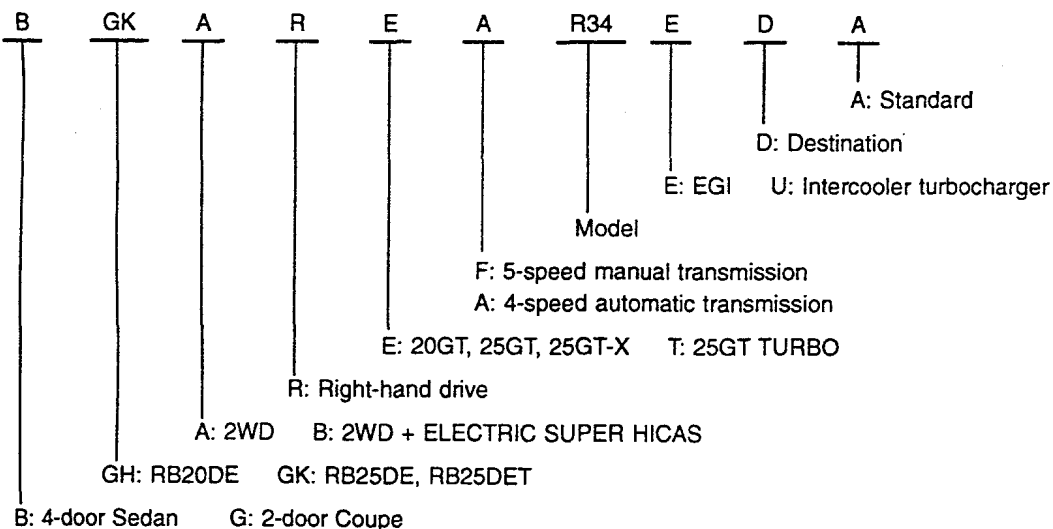

# IDENTIFICATION INFORMATION

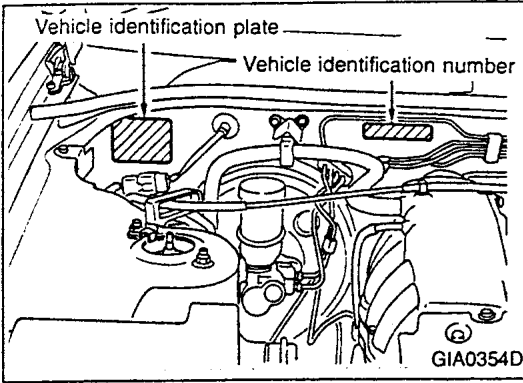

## Vehicle Identification Number

The stamping position for vehicle identification number is at the right side of cowl top panel.

GF-HR34: From HR34-000001

GF-ER34: From ER34-000001

GF-ENR34: From ENR34-000001

## Vehicle Identification Plate

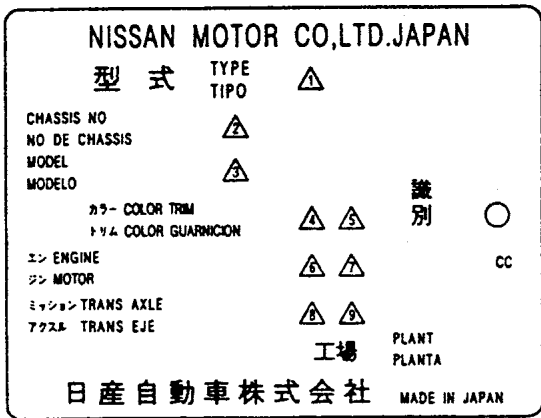

- △1 Type
- △2 Chassis No.
- △3 Model
- △4 Body color
- △5 Inner trim color
- △6 Engine type
- △7 Displacement
- △8 Transmission type
- △9 Transaxle type

GIA0018D

# ENGINE CONTROL SYSTEM

## SECTION **EC**

GI

EC

AT

BR

ST

RS

HA

EL

SD

## CONTENTS

<b>ENGINE AND EMISSION CONTROL OVERALL SYSTEM</b> .....	2
System Description.....	2
Description of Engine Control.....	2
System Diagram.....	3
Component Parts Location.....	6
Vacuum Hose Drawing.....	8
Circuit Diagram.....	11
ECM (.TCM) Terminal Layout.....	13
<b>TROUBLE DIAGNOSES</b> .....	15

Fail-Safe and Backup Functions.....	15
Self-diagnosis.....	16
<b>CONSULT</b> .....	19
Symptom Matrix Chart.....	28
Idle Speed Inspection and Adjustment.....	35
Ignition Timing Inspection and Adjustment.....	36
Air/Fuel Ratio Inspection.....	37
Fuel Pressure Inspection.....	38
ECM (.TCM) Input/Output Signal Reference Value.....	39



# ENGINE AND EMISSION CONTROL OVERALL SYSTEM

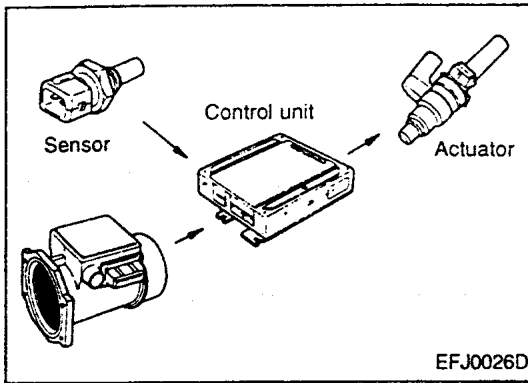

## System Description

The engine control system, which performs various controls such as the fuel injection control and ignition timing control with a single control unit, has been adopted.

Diagnostic system applicable to CONSULT has been adopted for easier inspection, service, and trouble diagnostic operations.

## Description of Engine Control

Item	Description	RB20DE (L/B)	RB25DE	RB25DET
Fuel injection control	<ul style="list-style-type: none"> <li>Performs optimum fuel injection for every operation condition for improved exhaust performance and response.</li> <li>Adopts SOFIS (Sophisticated and Optimized Fuel Injection System) control for optimized fuel injection.</li> <li>Adopts air/fuel ratio feedback learning control that performs compensation of air/fuel ratio for improved drivability when the system is in a transitional condition due to sudden change in air/fuel ratio.</li> </ul>	○	○	○
Ignition timing control	<ul style="list-style-type: none"> <li>Uses an ignition timing map stored in the control unit to perform controls so that the optimum ignition timing is obtained for every operating condition.</li> <li>Performs knock control, in which the ignition timing is advanced/retarded according to the presence of knocking, so that the optimum ignition timing is obtained for every operating condition and type of fuel.</li> </ul>	○	○	○
Idle speed control	<ul style="list-style-type: none"> <li>Performs feedback control to obtain the target idle speed for various conditions, such as during warm-up or when the air conditioner is actuated, via the AAC valve that adjusts the intake air amount when the throttle valve is fully closed.</li> </ul>	○	○	○
Fuel pump drive control	<ul style="list-style-type: none"> <li>Turns the fuel pump relay ON/OFF according to the engine speed signal.</li> <li>In RB25DET model, FPCM (Fuel Pump Control Modulator) control has been adopted for reduced idle noise.</li> </ul>	○	○	○
Heated oxygen sensor heater control	<ul style="list-style-type: none"> <li>Promotes warm-up of the heated oxygen sensor for improved air/fuel ratio feedback function.</li> </ul>	○	○	○
Air conditioner cut control	<ul style="list-style-type: none"> <li>Turns the air conditioner relay OFF at starting or during acceleration to reduce the engine load.</li> </ul>	○	○	○
Auxiliary electric fan control	<ul style="list-style-type: none"> <li>Turns the auxiliary electric fan relay ON/OFF according to the engine coolant temperature signal and air conditioner signal.</li> </ul>	—	○	○
Engine, A/T, TCS/ABS integrated control	<ul style="list-style-type: none"> <li>Reduces engine torque during gearshift or when TCS (Traction Control System) is being operated via a multiplex communication line.</li> </ul>	○	○	○
Variable valve timing control	<ul style="list-style-type: none"> <li>According to the engine speed and load, controls the cam phase by hydraulic pressure to change intake valve open/close timing for increased engine torque at low and middle speeds and for enhanced output.</li> </ul>	○	○	○
Canister purge control	<ul style="list-style-type: none"> <li>Performs duty control of the canister purge air according to various operating conditions.</li> </ul>	○	○	○
Variable air intake valve control	<ul style="list-style-type: none"> <li>Controls the intake air passage in the intake manifold collector to increase engine torque at low and middle speeds and to enhance output.</li> </ul>	○	○	—
Air jet swirl control	<ul style="list-style-type: none"> <li>According to operation conditions, turns the air jet swirl control solenoid valve ON/OFF to open/close the air jet swirl control valve for stable combustion.</li> </ul>	○	—	—
Turbo pressure control	<ul style="list-style-type: none"> <li>Turns the Turbo pressure control solenoid valve ON/OFF according to operation conditions.</li> </ul>	—	—	○
Fail-safe and backup controls	<ul style="list-style-type: none"> <li>Ensures the vehicle's safe operation and enables the vehicle to be driven in an emergency when any of the system major components (microcomputer in the control unit, engine coolant temperature sensor, etc.) fails.</li> </ul>	○	○	○
Diagnostic system	<ul style="list-style-type: none"> <li>For easier trouble diagnosis, self-diagnostic system is adopted and the existing diagnostic system is modified so that CONSULT can be used.</li> </ul>	○	○	○

# ENGINE AND EMISSION CONTROL OVERALL SYSTEM

## System Diagram

RB20DE (L/B)

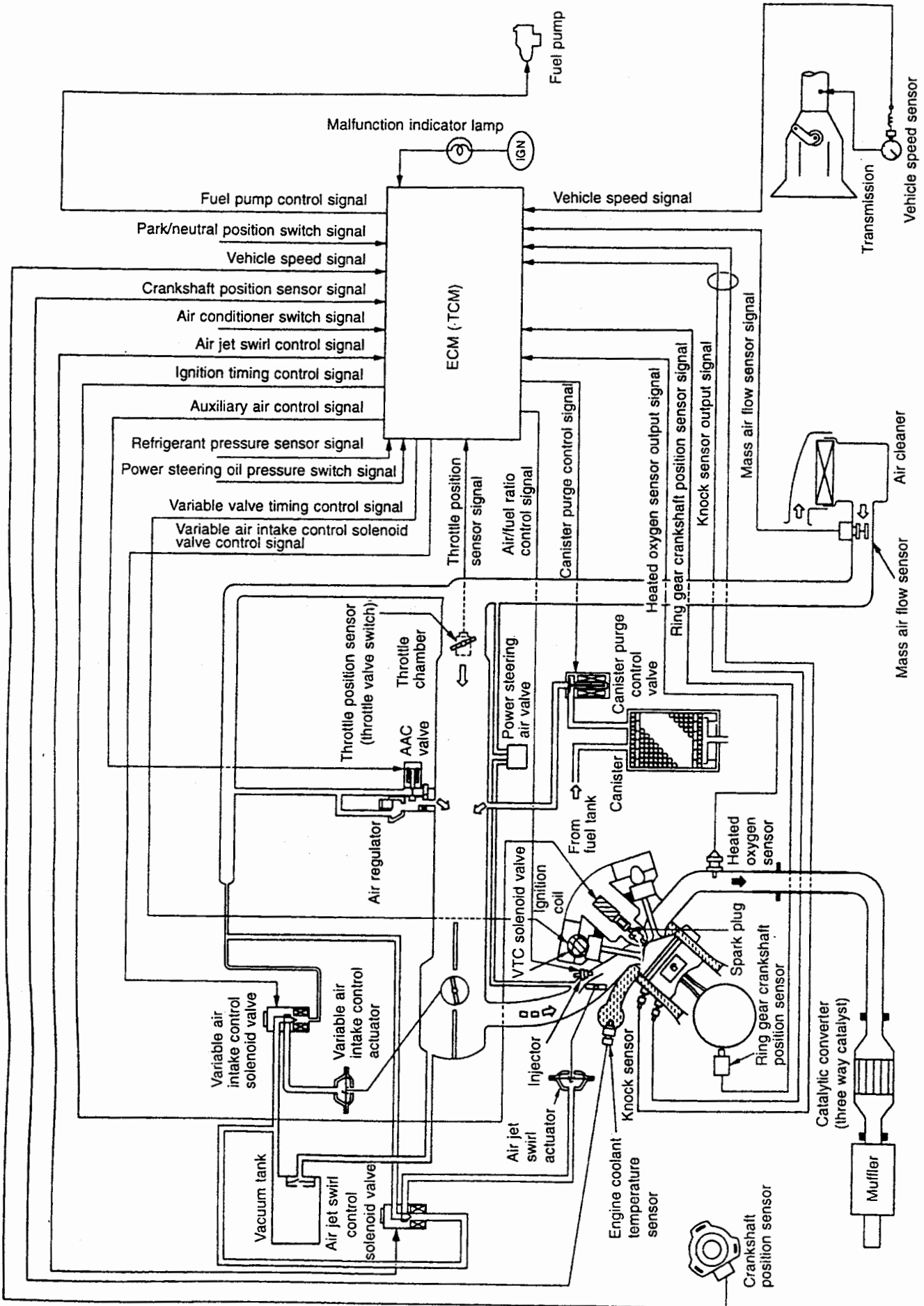

GI  
EC  
AT  
BR  
ST  
PS  
HA  
EL  
SD

# ENGINE AND EMISSION CONTROL OVERALL SYSTEM

## System Diagram (Cont'd)

RB25DE

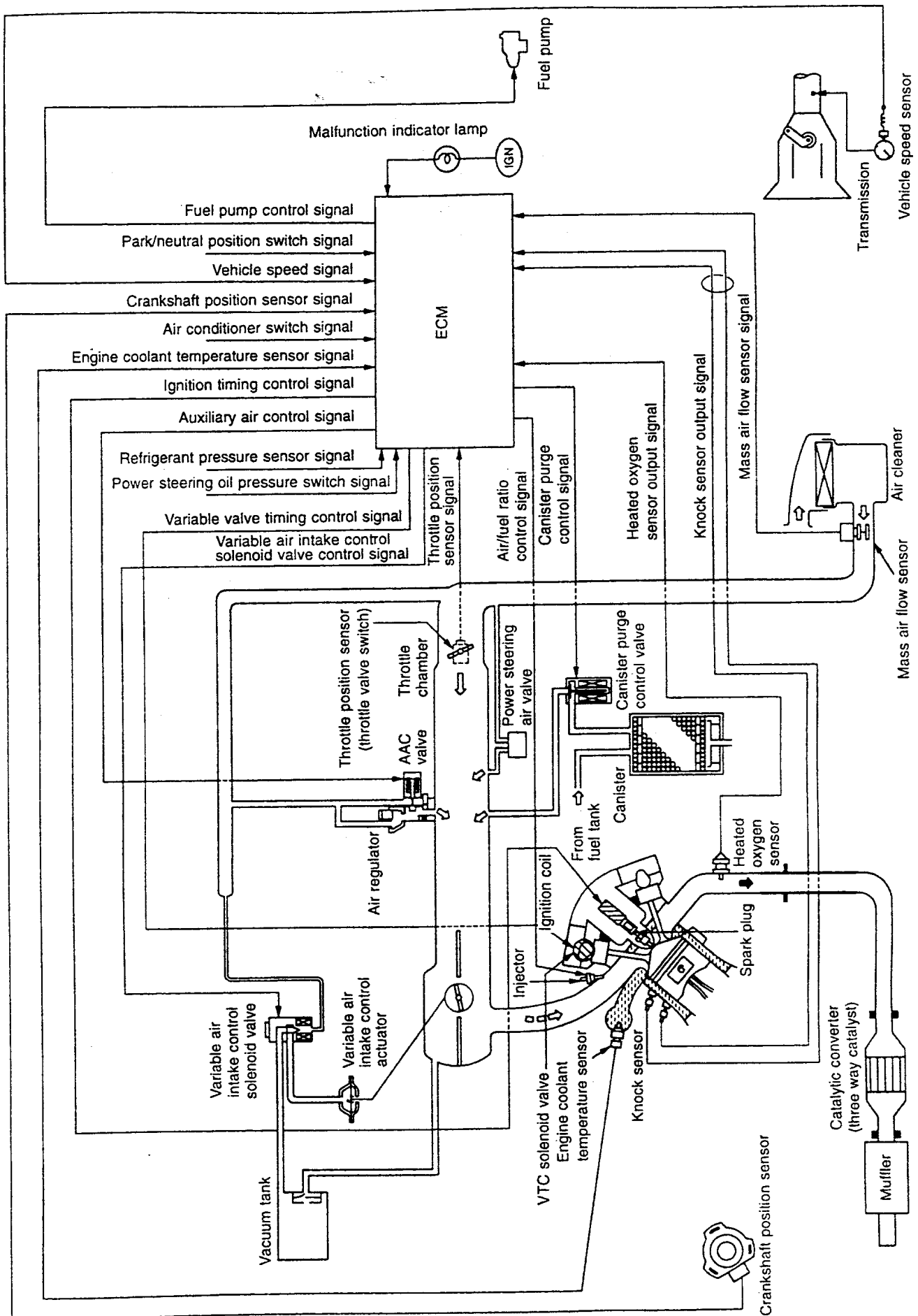

ECL1775D

# ENGINE AND EMISSION CONTROL OVERALL SYSTEM

## System Diagram (Cont'd)

RB25DET

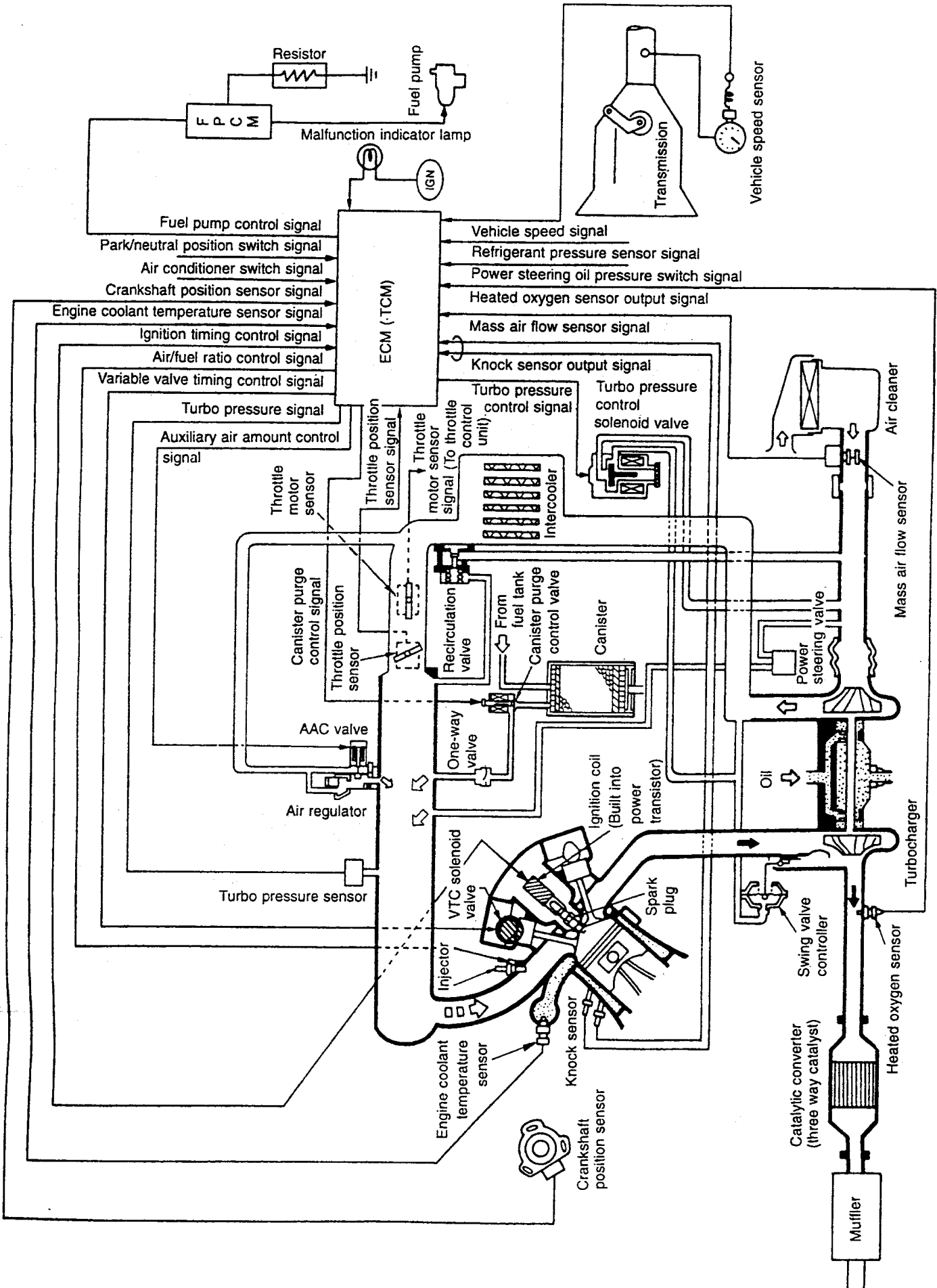

GI  
EC  
AT  
BR  
ST  
RS  
HA  
EL  
SD

ECL1776D

# ENGINE AND EMISSION CONTROL OVERALL SYSTEM

## Component Parts Location

RB20DE (L/B), RB25DE

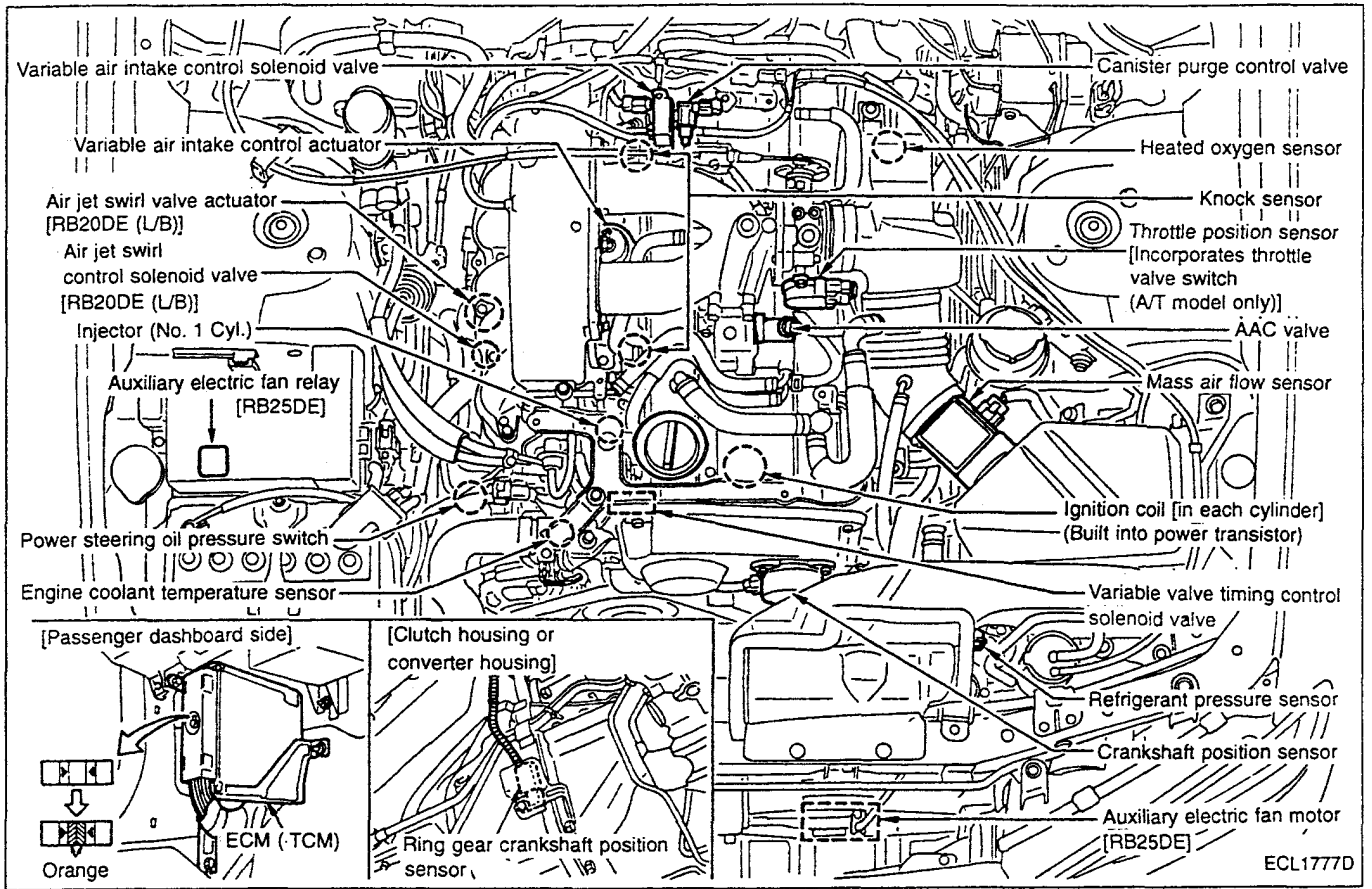

Component name		Type	Location	
Actuators	Fuel injector	High-resistance	Fuel tube	
	Fuel pump	Electric, turbine	Right rear of luggage compartment (in fuel tank)	
	IAA unit	AAC valve	Solenoid valve (Duty control)	Intake manifold collector (Upper)
		Air regulator	Wax	
	Ignition coil	Micro-mold (Built into power transistor)	Cylinder head (Top of each spark plug)	
	Canister purge control valve	Solenoid valve (Duty control)	Upper part of rocker cover	
	Variable valve timing control solenoid valve	Solenoid valve (ON-OFF control)	Front end of cylinder head	
	Variable intake control solenoid valve	Solenoid valve (ON-OFF control)	Upper part of rocker cover	
	Variable air intake control actuator	Diaphragm	Intake manifold collector	
	Air jet swirl solenoid valve [RB20DE (L/B)]	Solenoid valve (ON-OFF control)	Lower part of intake manifold	
Air jet swirl actuator [RB20DE (L/B)]	Diaphragm			
Sensors	Crankshaft position sensor	Photoelectric (Directly driven by camshaft)	Left front of cylinder head	
	Ring gear crankshaft position sensor [RB20DE (L/B)]	Magnetic	Clutch housing or converter housing	
	Mass air flow sensor	Hot wire	Air cleaner	
	Throttle position sensor [Incorporates throttle valve switch (A/T models only)]	Variable resistance	Throttle chamber	
	Engine coolant temperature sensor	Thermistor	Water outlet	
	Heated oxygen sensor	Zirconia (with heater)	Exhaust manifold	
	Knock sensor	Piezoelectric	Cylinder block	
	Power steering oil pressure switch	ON-OFF switch	Rear of radiator lower hose	
ECM (-TCM)		104-pin digital control	Passenger dashboard side	
ECM & IGN coil relay		Small universal relay (2M)	Passenger dashboard side Behind ECM (-TCM)	

# ENGINE AND EMISSION CONTROL OVERALL SYSTEM

## Component Parts Location (Cont'd)

RB25DET

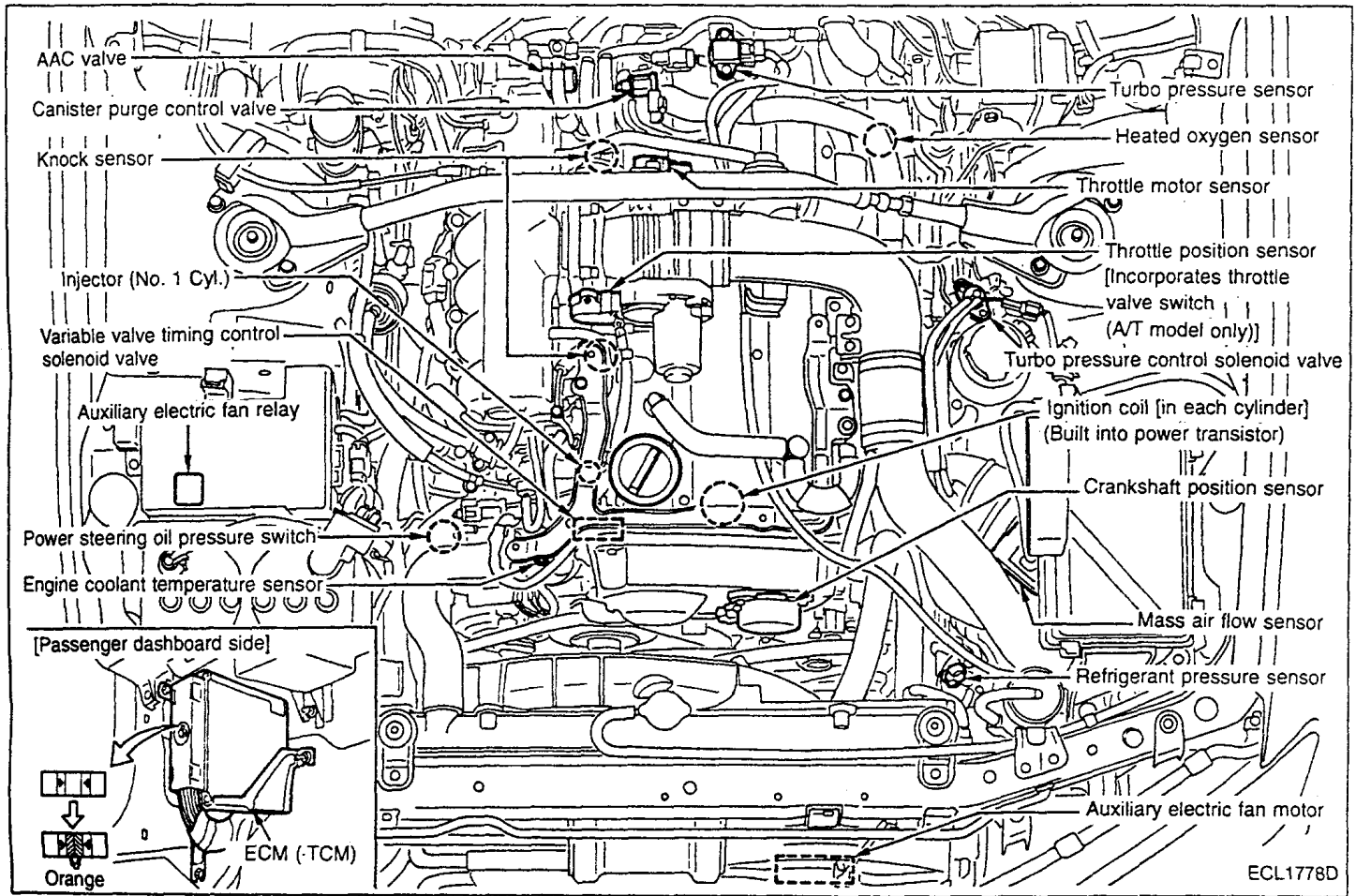

Component name		Type	Location	
Actuators	Fuel injector	High-resistance	Fuel tube	
	Fuel pump	Electric/turbine	Right rear of luggage compartment (in fuel tank)	
	IAA unit	AAC valve	Solenoid valve (Duty control)	Intake manifold collector
		Air regulator	Wax	
	Ignition coil	Micro-mold (Built into power transistor)	Cylinder head (Top of each spark plug)	
	Canister purge control valve	Solenoid valve (Duty control)	Upper part of rocker cover	
	Variable valve timing control solenoid valve	Solenoid valve (ON/OFF control)	Front end of cylinder head	
Turbo pressure control solenoid valve	Solenoid valve (ON/OFF control)	Next to left strut tower		
Sensors	Crankshaft position sensor	Photoelectric (Directly driven by camshaft)	Left front end of cylinder head	
	Mass air flow sensor	Hot wire	Air cleaner	
	Throttle position sensor [Incorporates throttle valve switch (A/T model only)]	Variable resistance	Throttle chamber	
	Throttle motor sensor	Variable resistance		
	Engine coolant temperature sensor	Thermistor	Water outlet	
	Heated oxygen sensor	Zirconia (with heater)	Turbocharger exhaust outlet	
	Knock sensor	Piezoelectric	Cylinder block	
	Turbo pressure sensor	Silicone diaphragm	Upper part of rocker cover	
	Power steering oil pressure switch	ON/OFF switch	Rear of radiator lower hose	
	Vehicle speed sensor	Electromagnetic power generation	Transmission	
ECM (-TCM)	104-pin digital control	Passenger dashboard side		
Fuel pump control modulator (FPCM)	Voltage control	Left rear of luggage compartment		
ECM & IGN coil relay	Small universal relay (2M)	Passenger dashboard side ECM (-TCM)		

# ENGINE AND EMISSION CONTROL OVERALL SYSTEM

## Vacuum Hose Drawing

RB20DE (L/B)

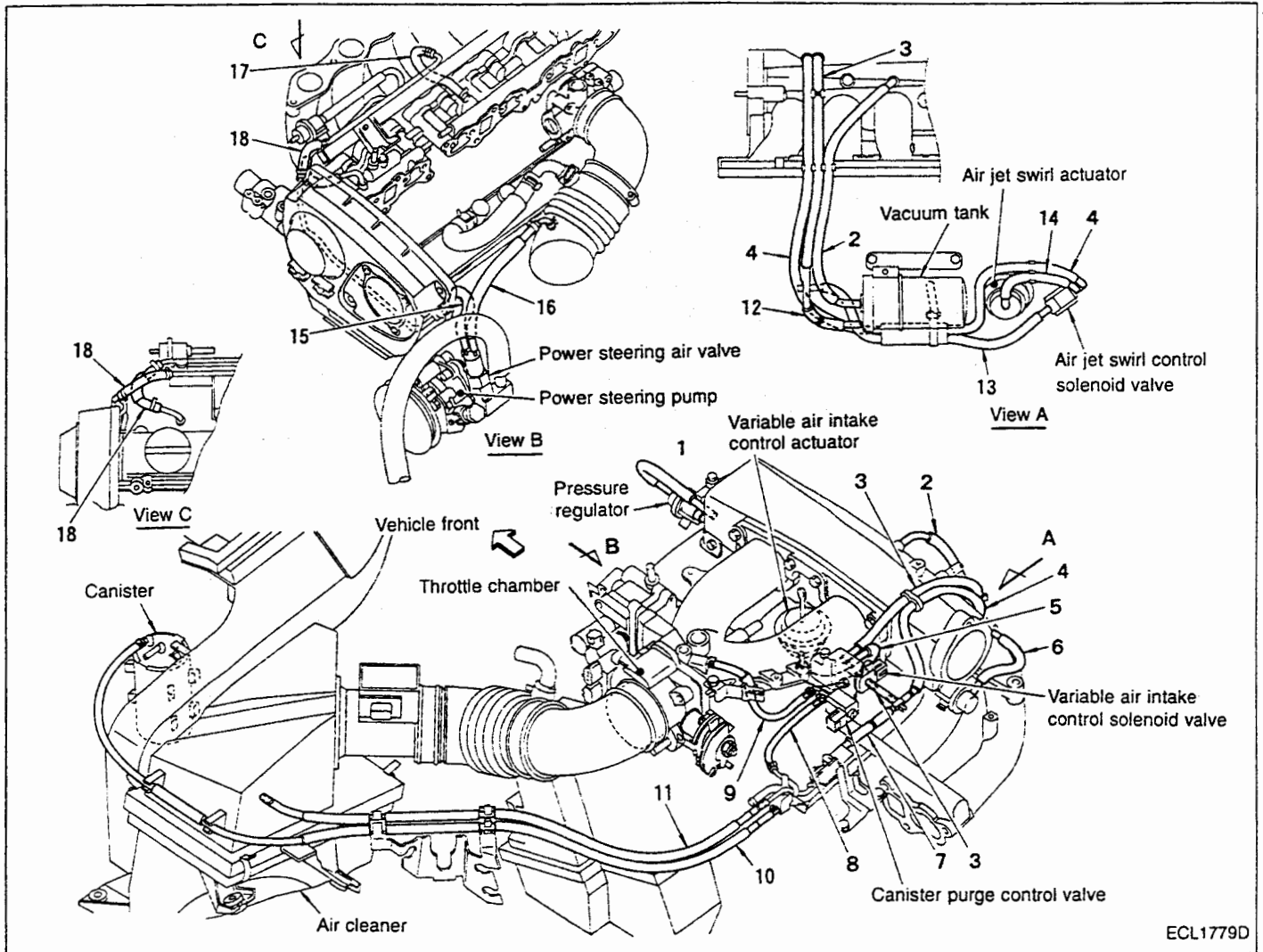

- |   |  |
|---|--|
| 1. Intake manifold collector to Pressure regulator                                    | 10. Canister to Vacuum gallery                                     |
| 2. Intake manifold collector to Vacuum tank   | 11. Air cleaner case to Vacuum gallery                             |
| 3. Variable air intake control solenoid valve to Three-way connector                  | 12. Vacuum tank to Three-way connector                             |
| 4. Air jet swirl control solenoid valve to Three-way connector                        | 13. Air jet swirl control solenoid valve to Three-way connector    |
| 5. Variable air intake control solenoid valve to Variable air intake control actuator | 14. Air jet swirl control solenoid valve to Air jet swirl actuator |
| 6. Intake manifold collector to Fuel damper   | 15. Power steering air valve to Vacuum pipe                        |
| 7. Vacuum pipe to Three-way connector   | 16. Power steering air valve to Air duct                           |
| 8. Canister purge control valve to Vacuum gallery                                     | 17. Air jet swirl assembly to Vacuum pipe                          |
| 9. Canister purge control valve to Throttle chamber                                   | 18. Vacuum pipe to Vacuum pipe                                     |

# ENGINE AND EMISSION CONTROL OVERALL SYSTEM

## Vacuum Hose Drawing (Cont'd)

RB25DE

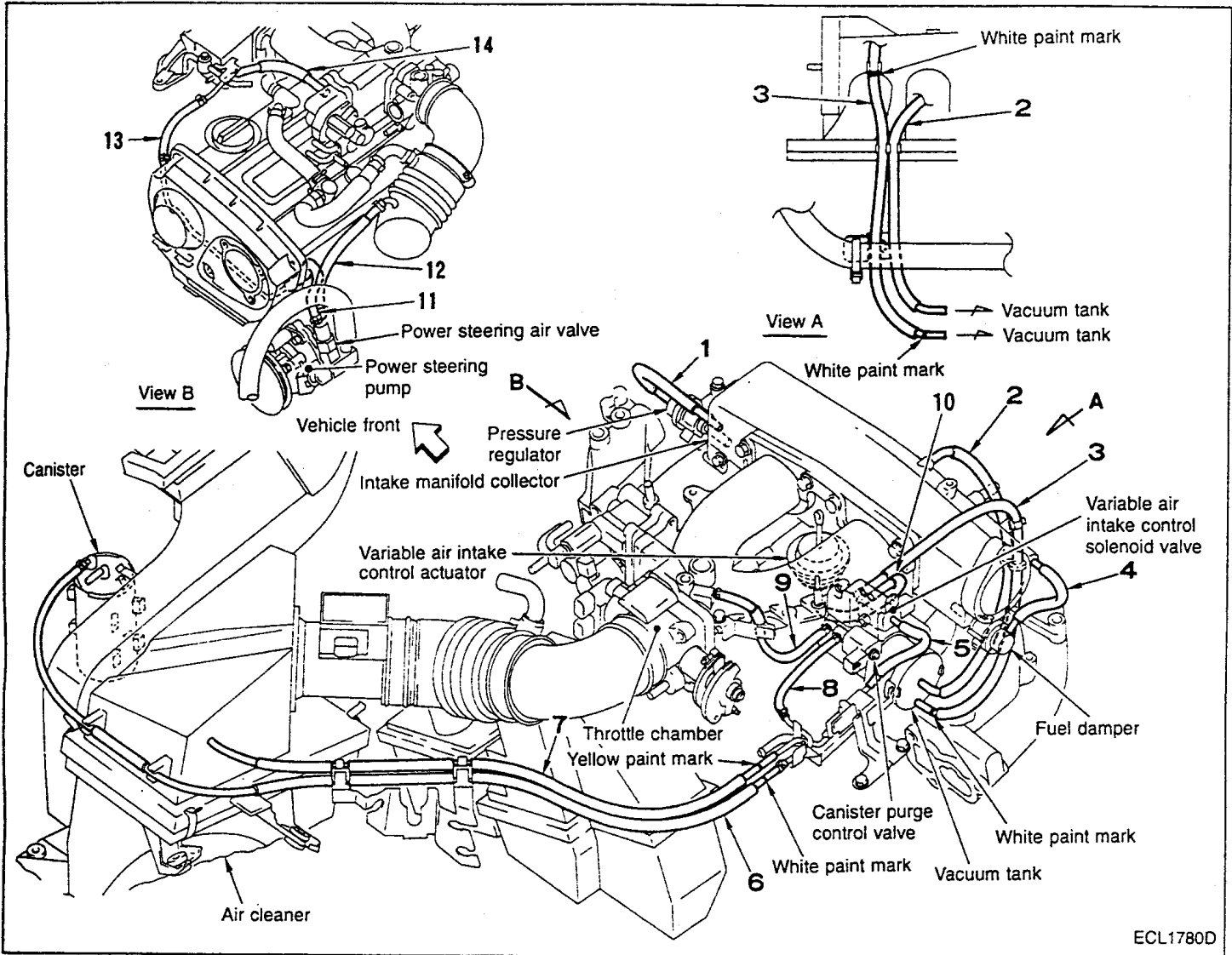

ECL1780D

- |  |   |
|--|---|
| <ol style="list-style-type: none"> <li>1. Intake manifold collector to Pressure regulator</li> <li>2. Intake manifold collector to Vacuum tank</li> <li>3. Variable air intake control solenoid valve to Vacuum tank</li> <li>4. Intake manifold collector to Fuel damper</li> <li>5. Variable air intake control solenoid valve to Vacuum pipe</li> <li>6. Canister to Vacuum gallery</li> <li>7. Air cleaner case to Vacuum gallery</li> </ol> | <ol style="list-style-type: none"> <li>8. Canister purge control valve to Vacuum gallery</li> <li>9. Canister purge control valve to Throttle chamber</li> <li>10. Variable air intake control solenoid valve to Variable air intake control actuator</li> <li>11. Power steering air valve to Vacuum pipe</li> <li>12. Power steering air valve to Air duct</li> <li>13. Vacuum pipe to Vacuum pipe</li> <li>14. AAC valve to Vacuum pipe</li> </ol> |
|--|---|

GI  
 EC  
 AT  
 BR  
 ST  
 RS  
 HA  
 EL  
 SD



# ENGINE AND EMISSION CONTROL OVERALL SYSTEM

## Vacuum Hose Drawing (Cont'd)

RB25DET

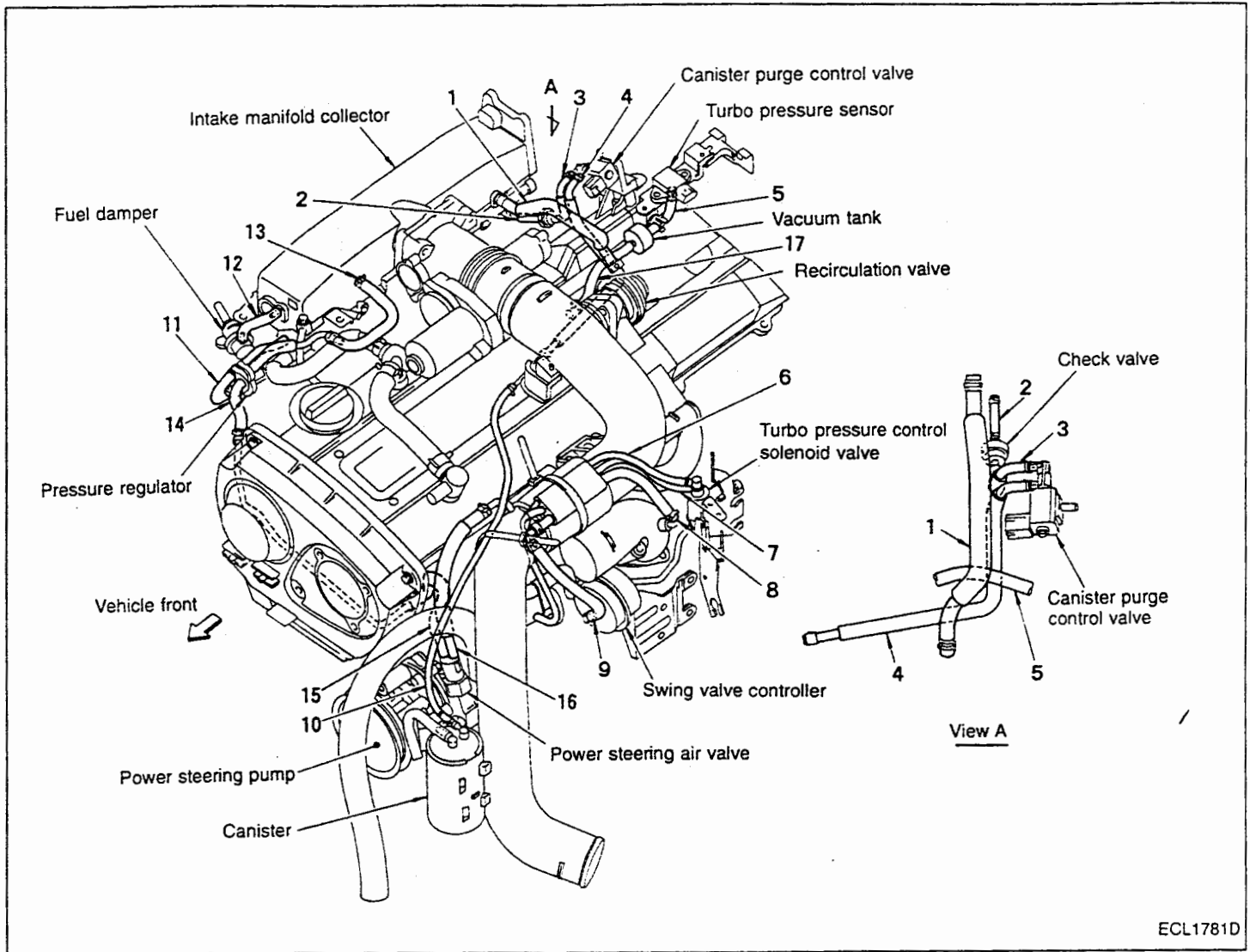

ECL1781D

- |  |  |
|--|--|
| <ol style="list-style-type: none"> <li>1. Intake manifold collector to Recirculation valve</li> <li>2. One-way valve to Intake manifold collector</li> <li>3. Canister purge control valve to One-way valve</li> <li>4. Canister purge control valve to Vacuum pipe</li> <li>5. Turbo pressure sensor to Vacuum tank</li> <li>6. Turbo pressure control solenoid valve to Air tube</li> <li>7. Turbo pressure control solenoid valve to Three-way connector</li> <li>8. Air inlet tube to Three-way connector</li> <li>9. Swing valve controller to Three-way connector</li> </ol> | <ol style="list-style-type: none"> <li>10. Canister to Vacuum pipe</li> <li>11. Pressure regulator to Intake manifold collector</li> <li>12. Fuel damper to Intake manifold collector</li> <li>13. Intake manifold collector to Vacuum pipe</li> <li>14. Vacuum pipe to Vacuum pipe</li> <li>15. Power steering air valve to Vacuum pipe</li> <li>16. Power steering air valve to Air inlet hose</li> <li>17. Air inlet pipe to Vacuum tank</li> </ol> |
|--|--|

# ENGINE AND EMISSION CONTROL OVERALL SYSTEM

## Circuit Diagram

RB20DE (L/B)-M/T, RB25DE, RB25DET M/T MODELS

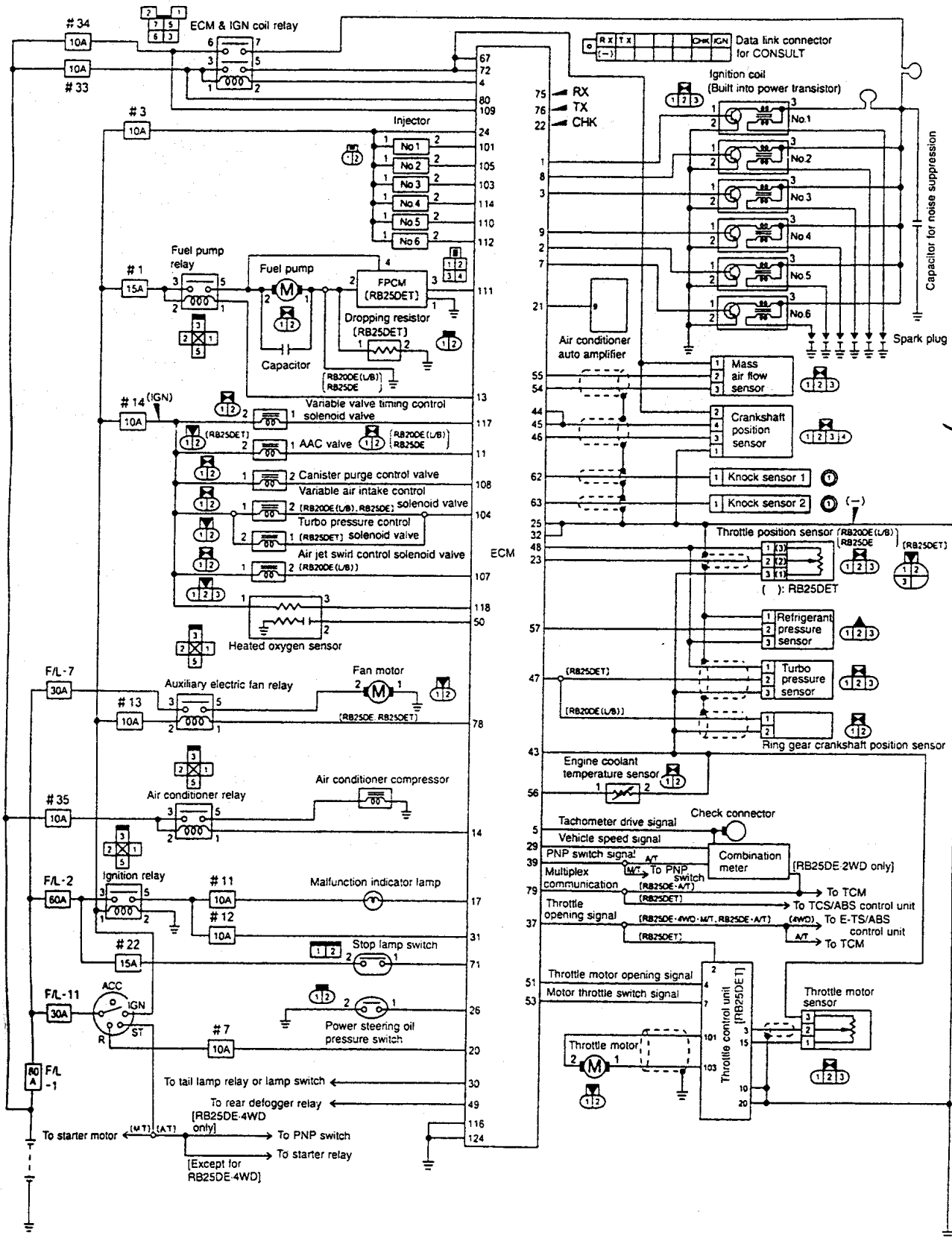

GI  
EC  
AT  
BR  
ST  
RS  
HA  
EL  
SD

# ENGINE AND EMISSION CONTROL OVERALL SYSTEM

## Circuit Diagram (Cont'd)

RB20DE (L/B)-A/T, RB25DET-A/T MODELS

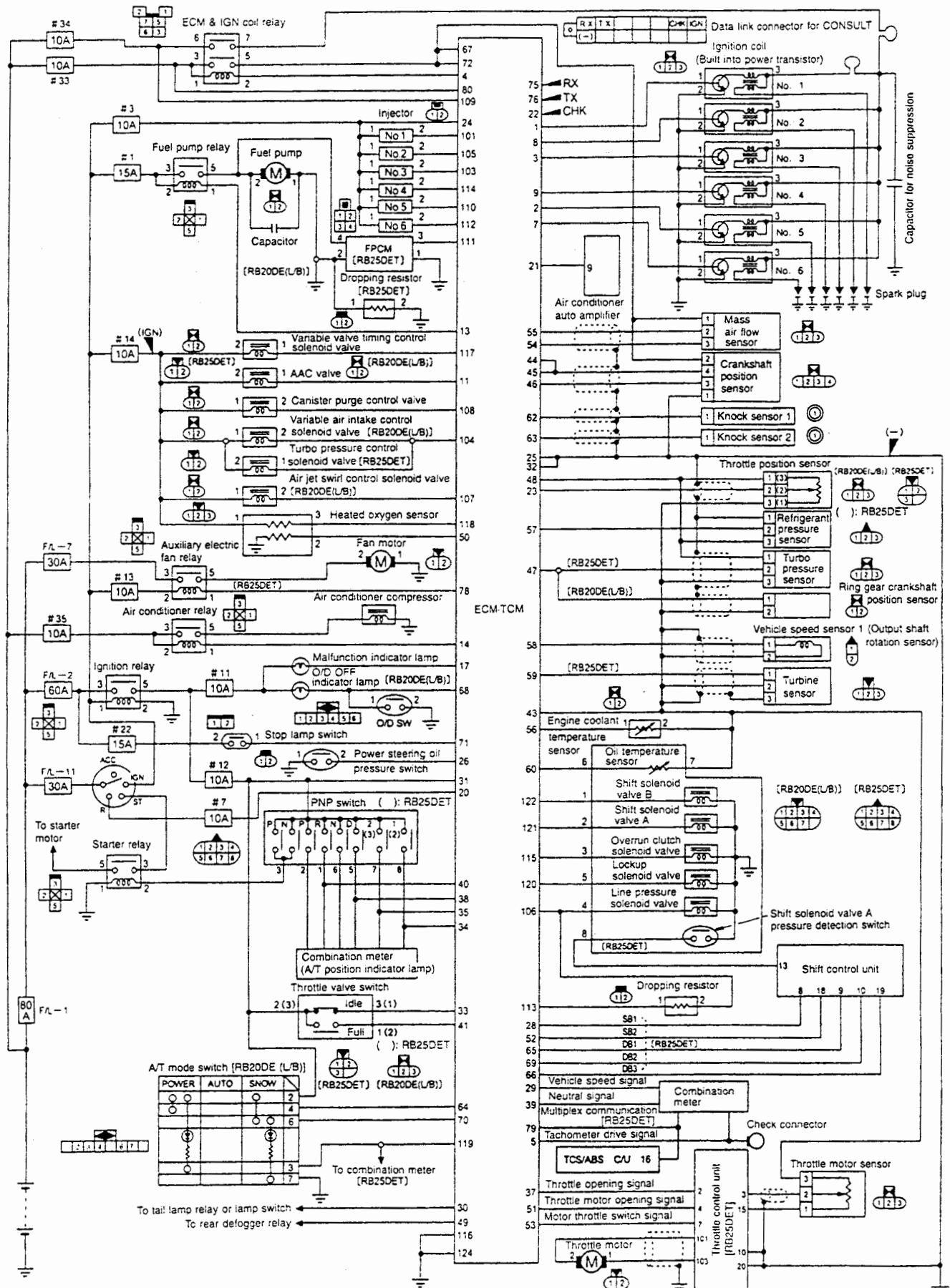

# ENGINE AND EMISSION CONTROL OVERALL SYSTEM

## ECM (.TCM) Terminal Layout

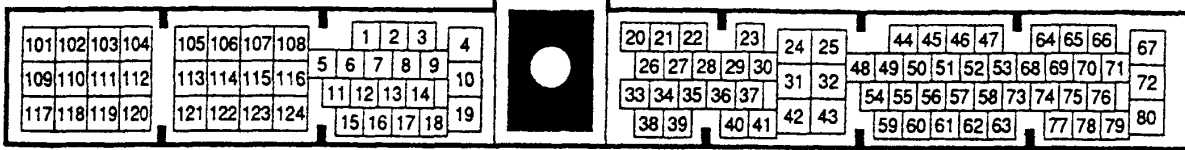

(Data link connector for CONSULT)

ECQ0357D

Terminal No.	Description	Terminal No.	Description
1	Ignition signal (Power transistor drive signal) Cyl. No. 1	*34	"1" position switch signal
2	Ignition signal (Power transistor drive signal) Cyl. No. 5	*35	"2" position switch signal
3	Ignition signal (Power transistor drive signal) Cyl. No. 3	36	—
4	ECM & IGN coil relay control signal	37	Throttle opening signal [RB25DE-4WD-M/T, RB25DE-A/T, RB25DET]
5	Tachometer drive signal	*38	"D" position switch signal
6	—	39	Neutral signal (Park/neutral position switch)
7	Ignition signal (Power transistor drive signal) Cyl. No. 6	*40	"R" position switch signal
8	Ignition signal (Power transistor drive signal) Cyl. No. 2	*41	Full switch signal
9	Ignition signal (Power transistor drive signal) Cyl. No. 4	42	—
10	—	43	Sensor ground
11	AAC valve control signal	44	Crankshaft position sensor 120° (REF) signal
12	—	45	Crankshaft position sensor 120° (REF) signal
13	Fuel pump relay control signal	46	Crankshaft position sensor 1° (POS) signal
14	Air conditioner relay control signal	47	Ring gear crankshaft position sensor signal [RB20DE (L/B)] Turbo pressure sensor signal [RB25DET]
15	—	48	Power supply for throttle position sensor, refrigerant pressure sensor, and turbo pressure sensor
16	—	49	Rear defogger switch signal
17	Malfunction indicator lamp	50	Heated oxygen sensor signal
18	—	51	Throttle motor sensor signal [RB25DET]
19	—	52	SB (select bit) 2 signal [RB25DET-A/T]
20	Ignition switch (START) signal	53	Motor throttle switch signal [RB25DET]
21	Air conditioner switch signal	54	Mass air flow sensor signal
22 (CHK)	Check (Diagnosis start)	55	Mass air flow sensor ground
23	Throttle position sensor signal	56	Engine coolant temperature sensor signal
24 (IGN)	Ignition switch (IGN) signal	57	Refrigerant pressure sensor signal
25	Control unit ground	*58	Output shaft rotation sensor signal (Vehicle speed sensor 1)
26	Power steering oil pressure switch signal	59	Turbine sensor signal [RB25DET-A/T]
27	—	*60	Oil temperature sensor signal
28	SB (select bit) 1 signal [RB25DET-A/T]	61	—
29	Vehicle speed sensor signal (Vehicle speed sensor 2)	62	Knock sensor signal 1
30	Headlamp switch signal	63	Knock sensor signal 2
31	Ignition power supply	64	A/T mode switch signal (POWER) [RB20DE (L/B)-A/T]
32	Control unit ground	65	DB (data bush) 1 signal [RB25DET-A/T]
*33	Idle position switch signal	66	DB (data bush) 3 signal [RB25DET-A/T]

Symbols in ( ) next to terminal numbers indicate the data link connector terminals. Items marked with \* are available on RB20DE (L/B) and RB25DET-A/T models only.

# ENGINE AND EMISSION CONTROL OVERALL SYSTEM

## ECM (·TCM) Terminal Layout (Cont'd)

Terminal No.	Description	Terminal No.	Description
67	Control unit power supply	74	—
*68	O/D OFF indicator lamp	75 (RX)	Receive (Data input to control unit)
69	DB (data bush) 2 signal [RB25DET·A/T]	76 (TX)	Transmit (Data output from control unit)
70	A/T mode switch signal (SNOW) [RB20DE (L/B)·A/T]	77	—
*71	Stop lamp switch signal	78	Auxiliary electric fan relay control signal [RB25DE, RB25DET]
72	Control unit power	79	ECM·TCM, TCS/ABS integrated control signal [Multiplex communication] [RB25DE·A/T, RB25DET]
73	—	80	Battery power supply
101	Injector No. 1 cylinder drive signal	*113	Line pressure solenoid valve control signal (Dropping resistor circuit)
102	—	114	Injector No. 4 cylinder drive signal
103	Injector No. 3 cylinder drive signal	*115	Overrun clutch solenoid valve control signal
104	Variable air intake control solenoid valve control signal [RB20DE (L/B), RB25DE] Turbo pressure control solenoid valve control signal [RB25DET]	116	Injector ground
105	Injector No. 2 cylinder drive signal	117	Variable timing control solenoid valve control signal
*106	Line pressure solenoid valve control signal	118	Heated oxygen sensor heater control signal
107	Air jet swirl control solenoid valve control signal [RB20DE (L/B)]	*119	Power indicator lamp
108	Canister purge control valve control signal	*120	Lockup solenoid valve control signal
109	Control unit power supply (Counter-electromotive current feedback circuit)	*121	Shift solenoid valve A control signal
110	Injector No. 5 cylinder drive signal	*122	Shift solenoid valve B control signal
111	Fuel pump terminal voltage control output signal [RB25DET]	123	—
112	Injector No. 6 cylinder drive signal	124	Injector ground

Symbols in ( ) next to terminal numbers indicate the data link connector terminals. Items marked with \* are available on RB20DE (L/B) and RB25DET·A/T models only.

# TROUBLE DIAGNOSES

## Fail-Safe and Backup Functions

- The fail-safe function estimates the opening conditions with other input signals and selects safer conditions for the engine (vehicle) control, based on the data previously stored in the control unit, when any of the critical sensors in the ECM fails.
- The backup function allows the vehicle to be driven, using control signals previously stored in the control unit, even if the critical part of the system fails.

Function	Related sensor	Malfunction	Fail-safe/backup	MIL indication	
Backup	ECM (-TCM)	The microcomputer in the control unit (CPU) is malfunctioning.	Fixes the ignition timing, fuel injection pulse width, and AAC valve opening to the preset values so that the vehicle can be driven.	MIL lights up.	GI <b>EC</b> AT
Fail-safe function	Mass air flow sensor	Output voltage dropped below 0.3V while the engine is running.	Selects the fuel injection pulse width according to the engine speed and the throttle opening so that the vehicle can be driven. Fuel injection will be inhibited when the engine speed exceeded approx. 2,400 rpm. During fail-safe control, idle speed is controlled to 800 rpm.	MIL lights up.	BR ST
	Engine coolant temperature sensor	Same as self-diagnostic malfunction detection conditions.	Uses the estimated engine coolant temperature (varies with elapsed time after start) to perform controls so that the vehicle can be driven normally. The auxiliary electric fan relay is turned ON. On RB25DET model, the turbo pressure control solenoid valve remains OFF.	MIL lights up.	RS HA
	Heated oxygen sensor	Heated oxygen sensor output voltage exceeded approx. 2V for predetermined time.	Inhibits air/fuel ratio feedback control.	MIL lights up.	EL
	Knock sensor	Same as self-diagnostic malfunction detection conditions.	Judges the vehicle as of regular specification. Retards the ignition timing within the knocking range so that the vehicle can be driven normally.	—	SD
	Throttle position sensor	Same as self-diagnostic malfunction detection conditions.	Determines idle position according to the throttle position and the engine speed. Fixes the output to the preset value so that the vehicle can be driven normally. On RB25DET model, the turbo pressure control solenoid valve remains OFF.	MIL lights up.	
	Throttle motor sensor	Same as self-diagnostic malfunction detection conditions.	Fixes the throttle motor sensor output to the preset value by turning the TCS switch ON/OFF, so that the vehicle can be driven normally.	MIL lights up.	
	Motor throttle switch	Same as self-diagnostic malfunction detection conditions.	Fixes the TCS switch OFF.	—	

# TROUBLE DIAGNOSES

## Self-diagnosis

### DESCRIPTION

- In self-diagnosis, when any of the critical sensors in the engine control system fails and the self-diagnostic malfunction detection conditions are satisfied, the malfunctioning system is stored in the control unit for easier trouble diagnosis.  
There are two methods to indicate the presence of a malfunction: By illuminating the malfunction indicator lamp (MIL) on the combination meter or by displaying on the CONSULT screen. Here describes indication by the malfunction indicator lamp.
- There are two types of diagnostic test modes: Mode I and Mode II. Mode I is normal status. Mode II is either SELF-DIAGNOSTIC RESULT or HEATED OXYGEN SENSOR MONITOR function.

### SELF-DIAGNOSIS OPERATION PROCEDURE

- To activate Diagnostic Test Mode II self-diagnosis, with the ignition switch turned ON (engine not running), connect terminals CHK and IGN on the data link connector for 2 or more seconds with a suitable harness, then disconnect them.
- Perform self-diagnosis with the ignition switch remain in ON position. [Mode II SELF-DIAGNOSTIC RESULTS]
- When engine is started in the above status, the heated oxygen sensor monitor function will be activated. [Mode II HEATED OXYGEN SENSOR MONITOR]
- When ignition switch is turned off during diagnosis, the diagnosis will automatically returns to Diagnostic Test Mode I. [Normal status]

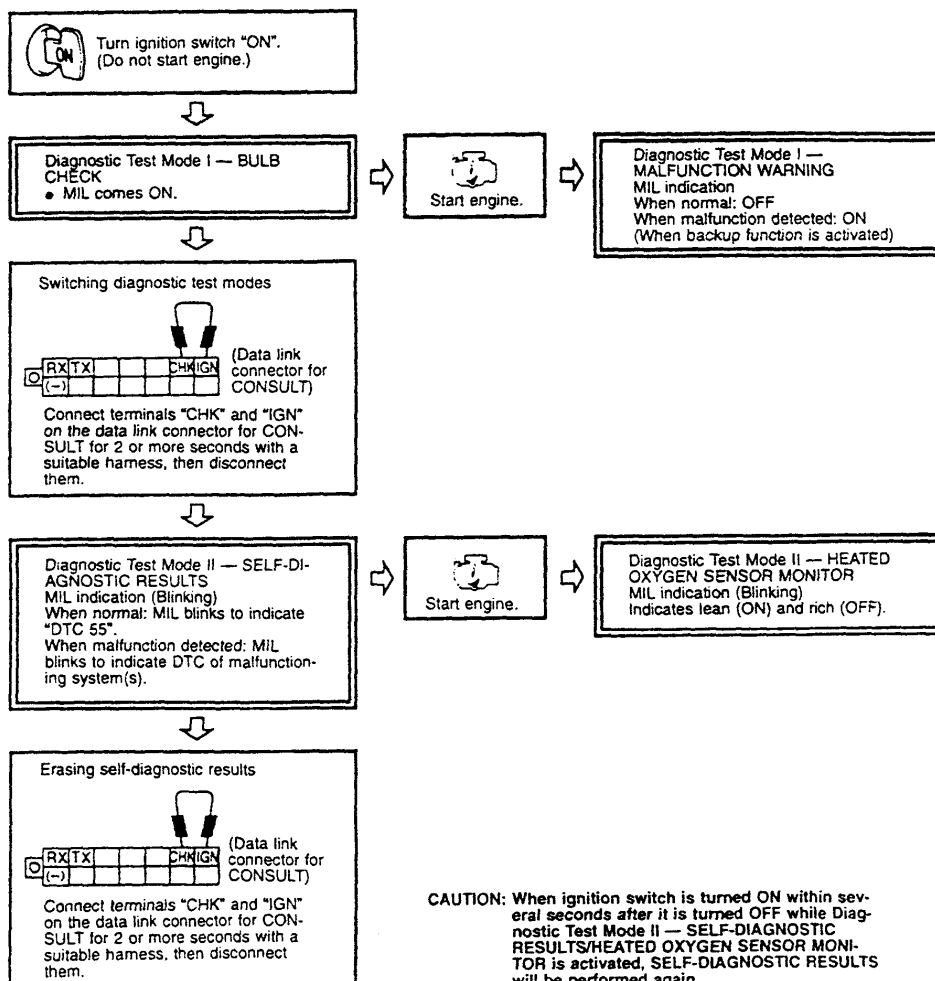

ECL1406D

# TROUBLE DIAGNOSES

## Self-diagnosis (Cont'd)

### MALFUNCTION INDICATOR LAMP (MIL) INDICATION

#### Diagnostic test mode I — BULB CHECK

- The malfunction indicator lamp bulb check is carried out when the ignition switch is turned ON (engine not started).
- The malfunction indicator lamp should come ON when the ignition switch is turned ON, and go OFF when the engine is started.

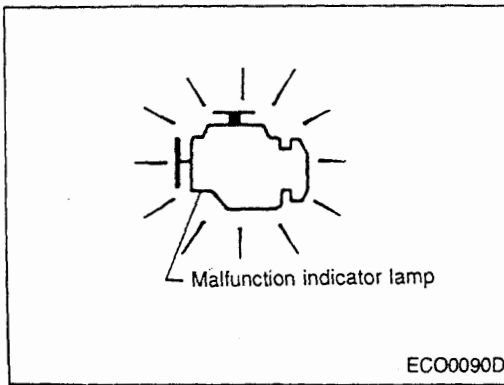

#### Diagnostic test mode I — MALFUNCTION WARNING

The system goes into the malfunction warning mode when any of the following conditions is satisfied, and warns the driver by lighting up the malfunction indicator lamp in the combination meter.

- Microcomputer in the ECM control unit (CPU) is malfunctioning.
- Malfunction is detected during mass airflow sensor circuit self-diagnosis.
- Malfunction is detected during engine coolant temperature sensor circuit self-diagnosis.
- Malfunction is detected during vehicle speed sensor circuit self-diagnosis.
- Malfunction is detected during ignition signal circuit self-diagnosis.
- Malfunction is detected during overheat self-diagnosis.
- Malfunction is detected during heated oxygen sensor circuit self-diagnosis.
- Malfunction is detected during throttle position sensor circuit self-diagnosis.
- Malfunction is detected during Turbo pressure sensor circuit self-diagnosis. [RB25DET model]
- Malfunction is detected during throttle motor sensor circuit self-diagnosis. [RB25DET model]

#### Diagnostic test mode II — SELF-DIAGNOSTIC RESULTS

- This mode indicates the malfunctioning system(s) by the malfunction indicator lamp blinking pattern (indicating the DTC).
- When no malfunction is detected, DTC "55" is indicated.

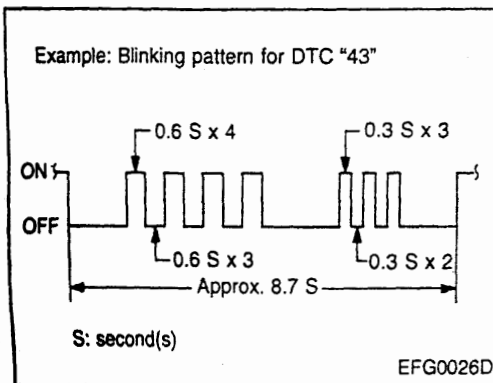

#### Diagnostic test mode II — HEATED OXYGEN SENSOR MONITOR

- This mode indicates status of the air/fuel ratio by blinks of the malfunction indicator lamp.
- Warm up the engine and increase and maintain the engine speed at 2,000 rpm. Check that the malfunction indicator lamp blinks at least five times in 10 seconds.
- During air/fuel ratio feedback control, when heated oxygen sensor output is high (rich): MIL goes OFF.
- when heated oxygen sensor output is low (lean): MIL comes ON.
- When air/fuel ratio feedback control is clamped: Status just before clamp is maintained.
- When air/fuel ratio feedback control is stopped: MIL goes OFF.

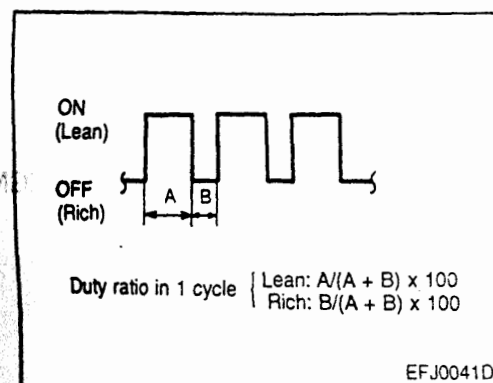



## TROUBLE DIAGNOSES

### Self-diagnosis (Cont'd)

#### SELF-DIAGNOSTIC INDICATION ITEMS

DTC No.	Self-diagnostic test items	Malfunction (DTC No.) indication conditions (Malfunction is detected when ...)	MIL indication
11	Crankshaft position sensor signal circuit	<ul style="list-style-type: none"> <li>1° (POS) signal or 120° (REF) signal is not input for predetermined time while the engine is running.</li> <li>Abnormal correlation is detected between 1° (POS) signal and 120° (REF) signal.</li> </ul>	—
12	Mass air flow sensor signal circuit	<ul style="list-style-type: none"> <li>Mass air flow sensor output voltage is 4.9V or greater for predetermined time when ignition switch is turned from OFF to ON, or after the engine is stalled.</li> <li>Mass air flow sensor output voltage is less than 0.3V for predetermined time while the engine is running.</li> </ul>	MIL lights up.
13	Engine coolant temperature sensor signal circuit	<ul style="list-style-type: none"> <li>Engine coolant temperature sensor output voltage is approx. 4.8V or greater (open circuit) or less than 0.06V (short circuit) for predetermined time.</li> </ul>	MIL lights up.
14	Vehicle speed sensor signal circuit	<ul style="list-style-type: none"> <li>No vehicle speed signal is input for predetermined time while the vehicle is being driven after warm up.</li> </ul>	MIL lights up.
16	Motor throttle switch signal circuit [RB25DET]	<ul style="list-style-type: none"> <li>Abnormal correlation is detected between input voltages from the throttle motor sensor and from the motor throttle switch for predetermined time.</li> </ul>	—
17	ABS-TCS control unit circuit [RB25DET]	<ul style="list-style-type: none"> <li>Throttle control unit detects malfunction in the system. (Open throttle sensor harness, etc.)</li> <li>TCS/ABS control unit detects malfunction.</li> </ul>	—
21	Ignition signal circuit	<ul style="list-style-type: none"> <li>No consecutive ignition signal while the engine is running.</li> </ul>	MIL lights up.
26	Turbo pressure sensor signal circuit [RB25DET]	<ul style="list-style-type: none"> <li>Turbo pressure sensor output voltage is approx. 4.8V or greater (open circuit) or less than 0.06V (short circuit) for predetermined time.</li> </ul>	MIL lights up.
28	Overheat	<ul style="list-style-type: none"> <li>Engine coolant temperature sensor output voltage is approx. 0.35V or less (sensor normal) for predetermined time.</li> </ul>	MIL lights up.
33	Heated oxygen sensor signal circuit	<ul style="list-style-type: none"> <li>Heated oxygen sensor output voltage is approx. 0.2V or greater and less than approx. 0.4V for predetermined time while the vehicle is being driven after warm up.</li> <li>Heated oxygen sensor output voltage is approx. 2V or greater for predetermined time.</li> </ul>	MIL lights up.
34	Knock sensor signal circuit	<ul style="list-style-type: none"> <li>At least one knock sensor indicates the output voltage of approx. 4V or greater (open circuit) or less than approx. 1V (short circuit).</li> </ul>	—
43	Throttle position sensor signal circuit	<ul style="list-style-type: none"> <li>Throttle position sensor output voltage is approx. 4.7V or greater (open circuit) or less than 0.06V (short circuit) for predetermined time while park/neutral position switch is OFF and vehicle speed is 4 km/h or higher.</li> </ul>	MIL lights up.
44	ABS-TCS communication circuit [RB25DET]	<ul style="list-style-type: none"> <li>Malfunction (open/short circuit, etc.) is detected in multiplex communication line between engine and TCS/ABS.</li> </ul>	—
46	Throttle motor sensor signal circuit [RB25DET]	<ul style="list-style-type: none"> <li>Throttle motor sensor input voltage is approx. 4.8V or greater (open circuit) or less than 0.3V (short circuit) for predetermined time.</li> </ul>	MIL lights up.
54	A/T communication circuit	<ul style="list-style-type: none"> <li>Malfunction is detected in A/T communication circuit in ECM (-TCM). [RB20DE (L/B), RB25DET]</li> <li>Malfunction (open circuit, short circuit, etc.) is detected in multiplex communication line between ECM and TCM. [RB25DE]</li> </ul>	—
55	No malfunction	<ul style="list-style-type: none"> <li>No malfunction is detected in all the above circuits.</li> </ul>	—

Some of the above self-diagnostic test items can cause related malfunctions to be detected in A/T, throttle control, and ABS self-diagnosis when malfunction is detected. Therefore, malfunctions should also be checked in self-diagnostic tests for systems other than engine.

#### CONDITIONS TO TURN OFF MALFUNCTION INDICATOR LAMP

Vehicle speed sensor signal circuit: Correct the sensor signal, then drive the vehicle at 4 km/h or higher.

Overheat: Check for causes of overheat, then erase self-diagnostic results.

Other items: Malfunction indicator lamp turns OFF when the vehicle returned to normal condition.

#### HOW TO ERASE SELF-DIAGNOSTIC RESULTS

In Diagnostic Test Mode II, with the engine stopped (ignition switch ON), connect terminals "CHK" and "IGN" on the data link connector for 2 or more seconds with a suitable harness, then disconnect them.

## CONSULT

### CONSULT INSPECTION PROCEDURE

1. Turn ignition switch OFF.
2. Connect "CONSULT" to data link connector for CONSULT.  
(Data link connector for CONSULT is located under the instrument lower cover on the driver's side on both LHD and RHD models.)

3. Turn ignition switch ON.
4. Touch "START".

5. Touch "ENGINE".

6. Perform each diagnostic test mode according to each service procedure.

**For further information, see the CONSULT Operation Manual.**

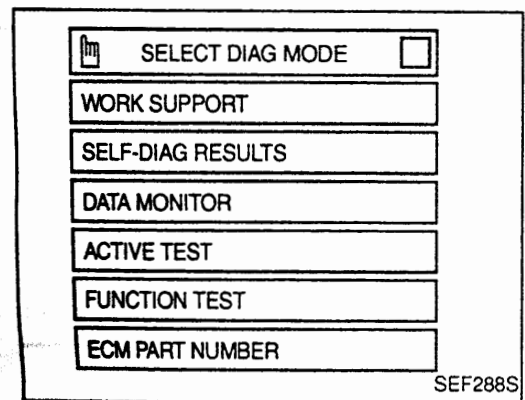
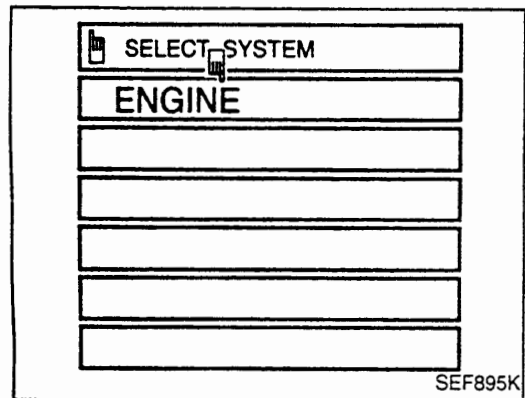
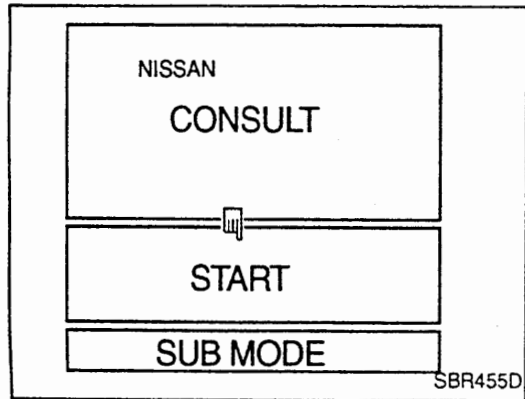
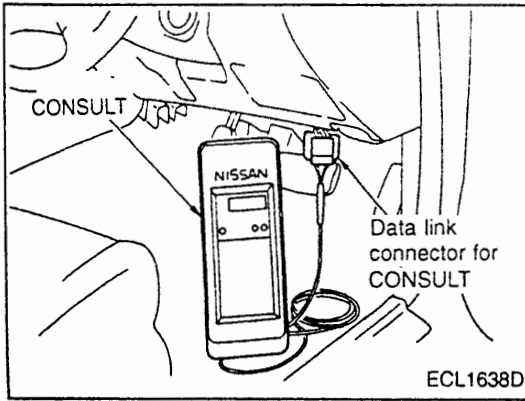

See  
the  
also

## TROUBLE DIAGNOSES

### CONSULT (Cont'd)

#### FUNCTION

Diagnostic test mode	Function
Work support	A technician can adjust some devices faster and more accurately by following indications on CONSULT.
Self-diagnostic results	Self-diagnostic results can be read and erased quickly.
Data monitor	Input/Output data in the ECM can be read.
Active test	CONSULT drives some actuators apart from the ECM's and also shifts some parameters in a specified range.
Function test	Conducted by CONSULT instead of a technician to determine whether each system is "OK" or "NG".
ECM part number	ECM part number can be read.

#### WORK SUPPORT MODE

WORK ITEM	CONDITION	USAGE
THRTL POS SEN ADJ	CHECK THE THROTTLE POSITION SENSOR SIGNAL. ADJUST IT TO THE SPECIFIED VALUE BY ROTATING THE SENSOR BODY UNDER THE FOLLOWING CONDITIONS. <ul style="list-style-type: none"> <li>● IGN SW "ON"</li> <li>● ENG NOT RUNNING</li> <li>● ACC PEDAL NOT PRESSED</li> </ul>	When adjusting throttle position sensor initial position
IACV-AAC VALVE ADJ	SET ENGINE SPEED AT THE SPECIFIED VALUE UNDER THE FOLLOWING CONDITIONS. <ul style="list-style-type: none"> <li>● ENGINE WARMED UP</li> <li>● NO-LOAD</li> </ul>	
FUEL PRESSURE RELEASE	<ul style="list-style-type: none"> <li>● FUEL PUMP WILL STOP BY TOUCHING "START" DURING IDLING.</li> <li>● CRANK A FEW TIMES AFTER ENGINE STALLS.</li> </ul>	When releasing fuel pressure from fuel line

# TROUBLE DIAGNOSES

## CONSULT (Cont'd)

### SELF-DIAGNOSTIC RESULTS MODE

When any of the control unit input/output signal circuits fails and the self-diagnostic malfunction detection conditions are satisfied, the malfunctioning circuit is stored in the memory and displayed later.

Self-diagnostic test items	Malfunction is detected when ...	Malfunction display item	Data storage (Yes/No)	
Crankshaft position sensor signal circuit	<ul style="list-style-type: none"> <li>1° (POS) signal or 120° (REF) signal is not input for predetermined time while the engine is running.</li> <li>Abnormal correlation is detected between 1° (POS) signal and 120° (REF) signal.</li> </ul>	Crankshaft position sensor	Yes	GI EC
Mass air flow sensor signal circuit	<ul style="list-style-type: none"> <li>Mass air flow sensor output voltage is 4.9V or greater for predetermined time when ignition switch is turned from OFF to ON, or after the engine is stalled.</li> <li>Mass air flow sensor output voltage is less than 0.3V for predetermined time while the engine is running.</li> </ul>	Mass air flow sensor	Yes	AT
Engine coolant temperature sensor signal circuit	<ul style="list-style-type: none"> <li>Engine coolant temperature sensor output voltage is approx. 4.8V or greater (open circuit) or less than 0.06V (short circuit) for predetermined time.</li> </ul>	Engine coolant temperature sensor	Yes	BR
Vehicle speed sensor signal circuit	<ul style="list-style-type: none"> <li>No vehicle speed signal is input for predetermined time while the vehicle is being driven after warm up.</li> </ul>	Vehicle speed sensor	Yes	ST
Motor throttle switch signal circuit [RB25DET]	<ul style="list-style-type: none"> <li>Abnormal correlation is detected between input voltages from the throttle motor sensor and from the motor throttle switch for predetermined time.</li> </ul>	Motor throttle switch	Yes	RS
ABS-TCS control unit circuit [RB25DET]	<ul style="list-style-type: none"> <li>Throttle control unit detects malfunction in the system. (Open throttle sensor harness, etc.)</li> <li>TCS/ABS control unit detects malfunction.</li> </ul>	ABS-TCS C/U SIGNAL	No	HA
Ignition signal circuit	<ul style="list-style-type: none"> <li>No consecutive ignition signal while the engine is running.</li> </ul>	Ignition switch (Start signal)	Yes	EL
Turbo pressure sensor signal circuit [RB25DET]	<ul style="list-style-type: none"> <li>Turbo pressure sensor output voltage is approx. 4.8V or greater (open circuit) or less than 0.06V (short circuit) for predetermined time.</li> </ul>	TURBO PRESS SENSOR	Yes	SD
Overheat	<ul style="list-style-type: none"> <li>Engine coolant temperature sensor output voltage is approx. 0.35V or less (sensor normal) for predetermined time.</li> </ul>	OVER HEAT	Yes	
Heated oxygen sensor signal circuit	<ul style="list-style-type: none"> <li>Heated oxygen sensor output voltage is approx. 0.2V or greater and less than approx. 0.4V for predetermined time while the vehicle is being driven after warm up.</li> <li>Heated oxygen sensor output voltage is approx. 2V or greater for predetermined time.</li> </ul>	Oxygen sensor	Yes	
Knock sensor signal circuit	<ul style="list-style-type: none"> <li>At least one knock sensor indicates the output voltage of approx. 4V or greater (open circuit) or less than approx. 1V (short circuit).</li> </ul>	Knock sensor	Yes	
Throttle position sensor signal circuit	<ul style="list-style-type: none"> <li>Throttle position sensor output voltage is approx. 4.7V or greater (open circuit) or 0.06V or less (short circuit) for predetermined time while park/neutral position switch is OFF and vehicle speed is 4 km/h or higher.</li> </ul>	Throttle position sensor	Yes	
ABS-TCS communication circuit [RB25DET]	<ul style="list-style-type: none"> <li>Malfunction (open/short circuit, etc.) is detected in multiplex communication line between engine and TCS/ABS.</li> </ul>	ABS/TCS C/U SIGNAL	No	
Throttle motor sensor signal circuit [RB25DET]	<ul style="list-style-type: none"> <li>Throttle motor sensor input voltage is approx. 4.8V or greater (open circuit) or less than 0.3V or less (short circuit) for predetermined time.</li> </ul>	Motor throttle sensor	Yes	
A/T communication circuit	<ul style="list-style-type: none"> <li>Malfunction is detected in A/T communication circuit in ECM (-TCM). [RB20DE (L/B), RB25DET]</li> <li>Malfunction (open/short circuit, etc.) is detected in multiplex communication line between ECM and TCM. [RB25DE]</li> </ul>	A/T COMM LINE	Yes	
No malfunction	<ul style="list-style-type: none"> <li>No malfunction is detected in all the above circuits.</li> </ul>	NO SELF DIAGNOSTIC FAILURE INDICATED. FURTHER TESTING MAY BE REQUIRED.	No	

Some of the above self-diagnostic test items can cause related malfunctions to be detected in A/T, throttle control, and ABS self-diagnosis when malfunction is detected. Therefore, malfunctions should also be checked in self-diagnostic tests for systems other than engine.

## TROUBLE DIAGNOSES

### CONSULT (Cont'd)

#### DATA MONITOR MODE

Monitored item [Unit]	ECM input signals	Main signals	Description	Remarks
CMPS-RPM (POS) [rpm]	<input type="radio"/>	<input type="radio"/>	<ul style="list-style-type: none"> <li>Indicates the engine speed computed from the POS signal (1° signal) of the camshaft position sensor.</li> </ul>	
MAS AIR/FL SE [V]	<input type="radio"/>	<input type="radio"/>	<ul style="list-style-type: none"> <li>The signal voltage of the mass air flow sensor is displayed.</li> </ul>	<ul style="list-style-type: none"> <li>When the engine is stopped, a certain value is indicated.</li> </ul>
COOLAN TEMP/S [°C] or [°F]	<input type="radio"/>	<input type="radio"/>	<ul style="list-style-type: none"> <li>The engine coolant temperature (determined by the signal voltage of the engine coolant temperature sensor) is displayed.</li> </ul>	<ul style="list-style-type: none"> <li>When the engine coolant temperature sensor is open or short-circuited, ECM enters fail-safe mode. The engine coolant temperature determined by the ECM is displayed.</li> </ul>
O2 SEN [V]*	<input type="radio"/>		<ul style="list-style-type: none"> <li>The signal voltage of the oxygen sensor is displayed.</li> </ul>	
M/R F/C MNT* [RICH/LEAN]	<input type="radio"/>	<input type="radio"/>	<ul style="list-style-type: none"> <li>Display of oxygen sensor signal during air-fuel ratio feedback control: RICH ... means the mixture became "rich", and control is being affected toward a leaner mixture. LEAN ... means the mixture became "lean", and control is being affected toward a rich mixture.</li> </ul>	<ul style="list-style-type: none"> <li>After turning ON the ignition switch, "RICH" is displayed until air-fuel mixture ratio feedback control begins.</li> <li>When the air-fuel ratio feedback is clamped, the value just before the clamping is displayed continuously.</li> </ul>
VHCL SPEED SE [km/h] or [mph]	<input type="radio"/>	<input type="radio"/>	<ul style="list-style-type: none"> <li>The vehicle speed computed from the vehicle speed sensor signal is displayed.</li> </ul>	
BATTERY VOLT [V]	<input type="radio"/>	<input type="radio"/>	<ul style="list-style-type: none"> <li>The power supply voltage of ECM is displayed.</li> </ul>	
THRTL POS SEN [V]	<input type="radio"/>	<input type="radio"/>	<ul style="list-style-type: none"> <li>The throttle position sensor signal voltage is displayed.</li> </ul>	
THRTL POS SE2 [V] ● RB25DET			<ul style="list-style-type: none"> <li>Throttle motor sensor output voltage</li> </ul>	<ul style="list-style-type: none"> <li>Approx. 4.6V</li> </ul>
TURBO BOOST SENSOR ● RB25DET			<ul style="list-style-type: none"> <li>Turbo pressure sensor output voltage</li> </ul>	<ul style="list-style-type: none"> <li>Approx. 2.7V</li> </ul>
START SIGNAL [ON/OFF]	<input type="radio"/>	<input type="radio"/>	<ul style="list-style-type: none"> <li>Indicates [ON/OFF] condition from the starter signal.</li> </ul>	<ul style="list-style-type: none"> <li>After starting the engine, [OFF] is displayed regardless of the starter signal.</li> </ul>
CLSD THL/P SW [ON/OFF]	<input type="radio"/>	<input type="radio"/>	<ul style="list-style-type: none"> <li>Indicates [ON/OFF] condition from the throttle position sensor signal.</li> </ul>	
AIR COND SIG [ON/OFF]	<input type="radio"/>	<input type="radio"/>	<ul style="list-style-type: none"> <li>Indicates [ON/OFF] condition of the air conditioner switch as determined by the air conditioner signal.</li> </ul>	
P/N POSI SW [ON/OFF]	<input type="radio"/>	<input type="radio"/>	<ul style="list-style-type: none"> <li>Indicates [ON/OFF] condition from the park/neutral position switch signal.</li> </ul>	
PW/ST SIGNAL [ON/OFF]	<input type="radio"/>	<input type="radio"/>	<ul style="list-style-type: none"> <li>[ON/OFF] condition of the power steering oil pressure switch determined by the power steering oil pressure signal is indicated.</li> </ul>	
LOAD SIGNAL [ON/OFF]	<input type="radio"/>	<input type="radio"/>	<ul style="list-style-type: none"> <li>Indicates [ON/OFF] condition from the electrical load signal and/or lighting switch. ON ... rear defogger is operating. OFF ... rear defogger is not operating.</li> </ul>	

**NOTE:**

Any monitored item that does not match the vehicle being diagnosed is deleted from the display automatically.

\*: Models with three way catalyst.

## TROUBLE DIAGNOSES

### CONSULT (Cont'd)

Monitored item [Unit]	ECM input signals	Main signals	Description	Remarks
INJ PULSE [msec]			<ul style="list-style-type: none"> <li>Indicates the actual fuel injection pulse width compensated by ECM according to the input signals.</li> </ul>	<ul style="list-style-type: none"> <li>When the engine is stopped, a certain computed value is indicated.</li> </ul>
IGN TIMING [BTDC]		○	<ul style="list-style-type: none"> <li>Indicates the ignition timing computed by ECM according to the input signals.</li> </ul>	<ul style="list-style-type: none"> <li>When the engine is stopped, a certain value is indicated.</li> </ul>
IACV-AAC/V [%]		○	<ul style="list-style-type: none"> <li>Indicates IACV-AAC/V control value computed by ECM according to the input signals.</li> </ul>	
PURG VOL C/V [ON/OFF duty]		○	<ul style="list-style-type: none"> <li>Indicates the EVAP canister purge volume control valve computed by the ECM according to the input signals.</li> <li>The opening becomes larger as the value increases.</li> </ul>	
A/F ALPHA [%]			<ul style="list-style-type: none"> <li>The mean value of the air-fuel ratio feedback correction factor per cycle is indicated.</li> </ul>	<ul style="list-style-type: none"> <li>When the engine is stopped, a certain value is indicated.</li> <li>This data also includes the data for the air-fuel ratio learning control.</li> </ul>
AIR COND RLY [ON/OFF]		○	<ul style="list-style-type: none"> <li>The air conditioner relay control condition (determined by ECM according to the input signal) is indicated.</li> </ul>	
FUEL PUMP RLY [ON/OFF]		○	<ul style="list-style-type: none"> <li>Indicates the fuel pump relay control condition determined by ECM according to the input signals.</li> </ul>	
INT/V TIM SOL [ON/OFF]			<ul style="list-style-type: none"> <li>The control condition of the intake valve timing control solenoid valve is indicated. ON ... Intake valve timing control is operating. OFF ... Intake valve timing control is not operating.</li> </ul>	
VIAS S/V [ON/OFF] ● RB20DE (L/B), RB25DE		○	<ul style="list-style-type: none"> <li>Control conditions computed by ECM Solenoid valve activated: ON Solenoid valve not activated: OFF</li> </ul>	
SWRL CONT S/V [ON/OFF] ● RB20DE (L/B)				
COOLING FAN [HI/LOW/OFF] ● RB25DE, RB25DET		○	<ul style="list-style-type: none"> <li>The control condition of the cooling fan (determined by ECM according to the input signal) is indicated. HI ... High speed operation LOW ... Low speed operation OFF ... Stop</li> </ul>	
TURBO CONT S/V ● RB25DET			<ul style="list-style-type: none"> <li>Control conditions computed by ECM Solenoid valve activated: ON Solenoid valve not activated: OFF</li> </ul>	
PD PRESSURE SENSOR [V]			<ul style="list-style-type: none"> <li>Refrigerant pressure sensor output voltage</li> </ul>	<ul style="list-style-type: none"> <li>Approx. 0.36V min. (Varies with air conditioner refrigerant pressure)</li> </ul>
VOLTAGE [V]			<ul style="list-style-type: none"> <li>Voltage measured by the voltage probe.</li> </ul>	
PULSE [msec] or [Hz] or [%]			<ul style="list-style-type: none"> <li>Pulse width, frequency or duty cycle measured by the pulse probe.</li> </ul>	<ul style="list-style-type: none"> <li>Only "#" is displayed if item is unable to be measured.</li> <li>Figures with "#"s are temporary ones. They are the same figures as an actual piece of data which was just previously measured.</li> </ul>

## TROUBLE DIAGNOSES

### CONSULT (Cont'd)

#### ACTIVE TEST MODE

TEST ITEM	CONDITION	JUDGEMENT	CHECK ITEM (REMEDY)
FUEL INJECTION	<ul style="list-style-type: none"> <li>●● Engine: Return to the original trouble condition</li> <li>● Change the amount of fuel injection using CONSULT.</li> </ul>	If trouble symptom disappears, see CHECK ITEM.	<ul style="list-style-type: none"> <li>● Harness and connector</li> <li>● Fuel injectors</li> <li>●● Oxygen sensor</li> </ul>
IACV-AAC/V OPENING	<ul style="list-style-type: none"> <li>●● Engine: After warming up, idle the engine.</li> <li>●● Change the IACV-AAC valve opening percent using CONSULT.</li> </ul>	Engine speed changes according to the opening percent.	<ul style="list-style-type: none"> <li>● Harness and connector</li> <li>●● IACV-AAC valve</li> </ul>
ENG COOLANT TEMP	<ul style="list-style-type: none"> <li>●● Engine: Return to the original trouble condition</li> <li>●● Change the engine coolant temperature using CONSULT.</li> </ul>	If trouble symptom disappears, see CHECK ITEM.	<ul style="list-style-type: none"> <li>● Harness and connector</li> <li>● Engine coolant temperature sensor</li> <li>● Fuel injectors</li> </ul>
IGNITION TIMING	<ul style="list-style-type: none"> <li>●● Engine: Return to the original trouble condition</li> <li>●● Timing light: Set</li> <li>●● Retard the ignition timing using CONSULT.</li> </ul>	If trouble symptom disappears, see CHECK ITEM.	<ul style="list-style-type: none"> <li>● Adjust ignition timing (by moving camshaft position sensor)</li> </ul>
POWER BALANCE	<ul style="list-style-type: none"> <li>● Engine: After warming up, idle the engine.</li> <li>●● A/C switch "OFF"</li> <li>● Shift lever "N"</li> <li>●● Cut off each injector signal one at a time using CONSULT.</li> </ul>	Engine runs rough or dies.	<ul style="list-style-type: none"> <li>●● Harness and connector</li> <li>●● Compression</li> <li>●● Injectors</li> <li>● Ignition coil with power transistor</li> <li>●● Spark plugs</li> </ul>
COOLING FAN ● RB25DE, RB25DET	<ul style="list-style-type: none"> <li>●● Ignition switch: ON</li> <li>●● Turn the cooling fan "ON" and "OFF" using CONSULT.</li> </ul>	Cooling fan moves and stops.	<ul style="list-style-type: none"> <li>●● Harness and connector</li> <li>●● Cooling fan motor</li> <li>●● Cooling fan relay</li> </ul>
FUEL PUMP RELAY	<ul style="list-style-type: none"> <li>● Ignition switch: ON (Engine stopped)</li> <li>● Turn the fuel pump relay "ON" and "OFF" using CONSULT and listen to operating sound.</li> </ul>	Fuel pump relay makes the operating sound.	<ul style="list-style-type: none"> <li>● Harness and connector</li> <li>●● Fuel pump relay</li> </ul>
VIAS SOL VALVE ● RB20DE (L/B), RB25DE	<ul style="list-style-type: none"> <li>●● Checks control items and output circuit by arbitrary ON/OFF operation.</li> </ul>		
VALVE TIMING SOL			
SWIRL CONT SOL VALVE ● RB20DE (L/B)			
SELF-LEARNING CONT	<ul style="list-style-type: none"> <li>● In this test, the coefficient of self-learning control mixture ratio returns to the original coefficient by touching "CLEAR" on the screen.</li> </ul>		
PURG VOL CONT/V	<ul style="list-style-type: none"> <li>● Engine: Run engine at 2,000 rpm.</li> <li>● Turn the EVAP canister purge control solenoid valve "ON" and "OFF" using CONSULT and listen for operating sound.</li> </ul>	EVAP canister purge control solenoid valve makes an operating sound. Check vacuum signal for EVAP canister purge control valve. VC ON ... Vacuum exists. VC OFF ... Vacuum does not exist.	<ul style="list-style-type: none"> <li>● Harness and connector</li> <li>●● EVAP canister purge control solenoid valve</li> <li>● Vacuum hose</li> </ul>

# TROUBLE DIAGNOSES

## CONSULT (Cont'd)

### REAL TIME DIAGNOSIS IN DATA MONITOR MODE

CONSULT has two kinds of triggers and they can be selected by touching "SETTING" in "DATA MONITOR" mode.

1. "AUTO TRIG" (Automatic trigger):

- The malfunction will be identified on the CONSULT screen in real time. In other words, malfunction item will be displayed at the moment the malfunction is detected by ECM. DATA MONITOR can be performed continuously until a malfunction is detected. However, DATA MONITOR cannot continue any longer after the malfunction detection.

2. "MANU TRIG" (Manual trigger):

- Malfunction item will not be displayed automatically on CONSULT screen even though a malfunction is detected by ECM. DATA MONITOR can be performed continuously even though a malfunction is detected.

Use these triggers as follows:

1. "AUTO TRIG"

- While trying to detect the DTC by performing the "DTC CONFIRMATION PROCEDURE", be sure to select to "DATA MONITOR (AUTO TRIG)" mode. You can confirm the malfunction at the moment it is detected.
- While narrowing down the possible causes, CONSULT should be set in "DATA MONITOR (AUTO TRIG)" mode, especially in case the incident is intermittent. When you are inspecting the circuit by gently shaking (or twisting) the suspicious connectors, components and harness in the "DTC CONFIRMATION PROCEDURE", the moment a malfunction is found the malfunction item will be displayed. (Refer to GI section, "Incident Simulation Tests" in "HOW TO PERFORM EFFICIENT DIAGNOSIS FOR AN ELECTRICAL INCIDENT".)

2. "MANU TRIG"

- If the malfunction is displayed as soon as "DATA MONITOR" is selected, reset CONSULT to "MANU TRIG". By selecting "MANU TRIG" you can monitor and store the data. The data can be utilized for further diagnosis, such as a comparison with the value for the normal operating condition.

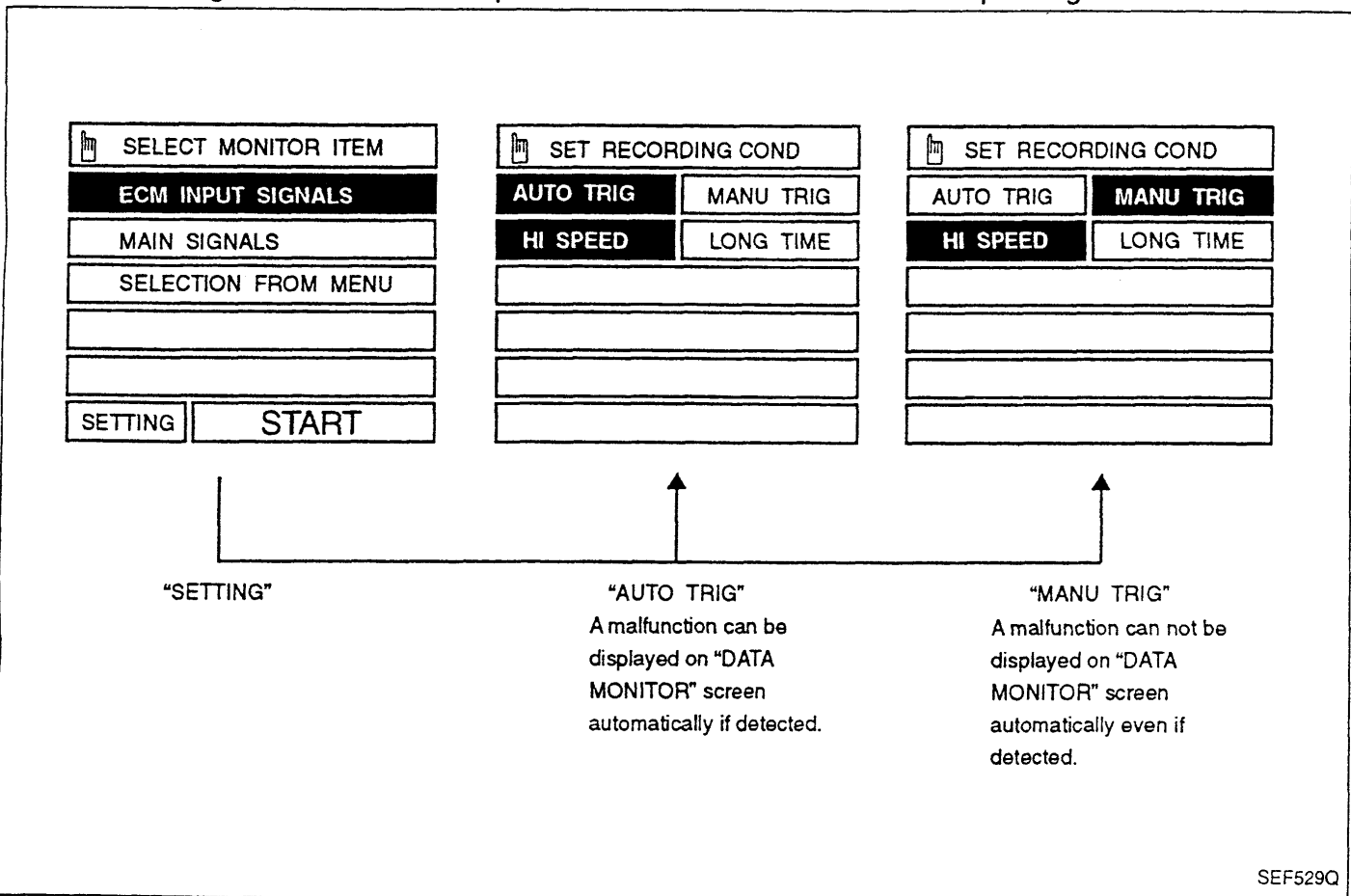

GI  
**EC**  
 AT  
 BR  
 ST  
 RS  
 HA  
 EL  
 SD



# TROUBLE DIAGNOSES

## CONSULT (Cont'd)

### FUNCTION TEST MODE

FUNCTION TEST ITEM	CONDITION	JUDGEMENT		CHECK ITEM (REMEDY)
SELF-DIAG RESULTS	<ul style="list-style-type: none"> <li>● Ignition switch: ON (Engine stopped)</li> <li>● Displays the results of on board diagnostic system.</li> </ul>	—		Objective system
CLOSED THROTTLE POSI	<ul style="list-style-type: none"> <li>● Ignition switch: ON (Engine stopped)</li> <li>● Throttle position sensor circuit is tested when throttle is opened and closed fully. ("IDLE POSITION" is the test item name for the vehicles in which idle is selected by throttle position sensor.)</li> </ul>	Throttle valve: opened	OFF	<ul style="list-style-type: none"> <li>● Harness and connector</li> <li>● Throttle position sensor (Closed throttle position)</li> <li>● Throttle position sensor (Closed throttle position) adjustment</li> <li>● Throttle linkage</li> <li>● Verify operation in DATA MONITOR mode.</li> </ul>
		Throttle valve: closed	ON	
THROTTLE POSI SEN CKT	<ul style="list-style-type: none"> <li>● Ignition switch: ON (Engine stopped)</li> <li>● Throttle position sensor circuit is tested when throttle is opened and closed fully.</li> </ul>	Range (Throttle valve fully opened — Throttle valve fully closed)	More than 3.0V	<ul style="list-style-type: none"> <li>● Harness and connector</li> <li>● Throttle position sensor</li> <li>● Throttle position sensor adjustment</li> <li>● Throttle linkage</li> <li>● Verify operation in DATA MONITOR mode.</li> </ul>
PARK/NEUT POSI SW CKT	<ul style="list-style-type: none"> <li>● Ignition switch: ON (Engine stopped)</li> <li>● Neutral position switch circuit is tested when shift lever is manipulated.</li> </ul>	Out of N/P positions	OFF	<ul style="list-style-type: none"> <li>● Harness and connector</li> <li>● Neutral position switch</li> <li>● Linkage adjustment</li> </ul>
		In N/P positions	ON	
FUEL PUMP CIRCUIT	<ul style="list-style-type: none"> <li>● Ignition switch: ON (Engine stopped)</li> <li>● Fuel pump circuit is tested by checking the pulsation in fuel pressure when fuel tube is pinched.</li> </ul>	There is pressure pulsation on the fuel feed hose.		<ul style="list-style-type: none"> <li>● Harness and connector</li> <li>● Fuel pump</li> <li>● Fuel pump relay</li> <li>● Fuel filter clogging</li> <li>● Fuel level</li> </ul>
VALVE TIMING S/V CKT	<ul style="list-style-type: none"> <li>● The valve timing control system is diagnosed by checking for operating sound of the solenoid valve.</li> </ul>			
COOLING FAN CIRCUIT ● RB25DE, RB25DET	<ul style="list-style-type: none"> <li>● Ignition switch: ON (Engine stopped)</li> <li>● Cooling fan circuit is tested when cooling fan is rotated.</li> </ul>	The cooling fan rotates and stops every 3 seconds.		<ul style="list-style-type: none"> <li>● Harness and connector</li> <li>● Cooling fan motor</li> <li>● Cooling fan relay</li> </ul>
START SIGNAL CIRCUIT	<ul style="list-style-type: none"> <li>● Ignition switch: ON → START</li> <li>● Start signal circuit is tested when engine is started by operating the starter. Battery voltage and water temperature before cranking, and average battery voltage, mass air flow sensor output voltage and cranking speed during cranking are displayed.</li> </ul>	Start signal: OFF → ON		<ul style="list-style-type: none"> <li>● Harness and connector</li> <li>● Ignition switch</li> </ul>

# TROUBLE DIAGNOSES

## CONSULT (Cont'd)

FUNCTION TEST ITEM	CONDITION	JUDGEMENT		CHECK ITEM (REMEDY)
PW/ST SIGNAL CIRCUIT	<ul style="list-style-type: none"> <li>Ignition switch: ON (Engine running)</li> <li>Power steering oil pressure switch circuit is tested when steering wheel is rotated fully and then set to a straight line running position.</li> </ul>	Locked position	ON	<ul style="list-style-type: none"> <li>Harness and connector</li> <li>Power steering oil pressure switch</li> <li>Power steering oil pump</li> </ul>
		Neutral position	OFF	
VIAS S/V CIRCUIT ● RB20DE (L/B), RB25DE	<ul style="list-style-type: none"> <li>The variable air intake system is diagnosed by checking for operation of the actuator.</li> </ul>			
SWRL CONT S/V CIRCUIT ● RB20DE (L/B)	<ul style="list-style-type: none"> <li>The air jet swirl control system is diagnosed by checking for operation of the actuator.</li> </ul>			
VEHICLE SPEED SEN CKT	<ul style="list-style-type: none"> <li>Vehicle speed sensor circuit is tested when vehicle is running at a speed of 10 km/h (6 MPH) or higher.</li> </ul>	Vehicle speed sensor input signal is greater than 4 km/h (2 MPH).		<ul style="list-style-type: none"> <li>Harness and connector</li> <li>Vehicle speed sensor</li> <li>Speedometer</li> </ul>
IGN TIMING ADJ	<ul style="list-style-type: none"> <li>After warming up, idle the engine.</li> <li>Ignition timing is checked by reading ignition timing with a timing light and checking whether it agrees with specifications.</li> </ul>	The timing light indicates the same value on the screen.		<ul style="list-style-type: none"> <li>Adjust ignition timing (by moving camshaft position sensor or distributor)</li> <li>Camshaft position sensor drive mechanism</li> </ul>
MIXTURE RATIO TEST	<ul style="list-style-type: none"> <li>Air-fuel ratio feedback circuit (injection system, ignition system, vacuum system, etc.) is tested by examining the oxygen sensor output at 2,000 rpm under non-loaded state.</li> </ul>	Oxygen sensor COUNT: More than 5 times during 10 seconds		<ul style="list-style-type: none"> <li>INJECTION SYS (Injector, fuel pressure regulator, harness or connector)</li> <li>IGNITION SYS (Spark plug, ignition coil, power transistor harness or connector)</li> <li>VACUUM SYS (Intake air leaks)</li> <li>Oxygen sensor circuit</li> <li>Oxygen sensor operation</li> <li>Fuel pressure high or low</li> <li>Mass air flow sensor</li> </ul>
POWER BALANCE	<ul style="list-style-type: none"> <li>After warming up, idle the engine.</li> <li>Injector operation of each cylinder is stopped one after another, and resultant change in engine rotation is examined to evaluate combustion of each cylinder. (This is only displayed for models where a sequential multipoint fuel injection system is used.)</li> </ul>	Difference in engine speed is greater than 25 rpm before and after cutting off the injector of each cylinder.		<ul style="list-style-type: none"> <li>Injector circuit (Injector, harness or connector)</li> <li>Ignition circuit (Spark plug, ignition coil, power transistor harness or connector)</li> <li>Compression</li> <li>Valve timing</li> </ul>
IACV-AAC/ SYSTEM	<ul style="list-style-type: none"> <li>After warming up, idle the engine.</li> <li>IACV-AAC valve system is tested by detecting change in engine speed when IACV-AAC valve opening is changed to 0%, 20% and 80%.</li> </ul>	Difference in engine speed is greater than 150 rpm between when valve opening is at 80% and at 20%.		<ul style="list-style-type: none"> <li>Harness and connector</li> <li>IACV-AAC valve</li> <li>Air passage restriction between air inlet and IACV-AAC valve</li> <li>IAS (Idle adjusting screw) adjustment</li> </ul>

GI  
 EC  
 AT  
 BR  
 ST  
 RS  
 HA  
 EL  
 SD

### ECM PART NUMBER

Part number of the ECM equipped on the vehicle can be read.

ECM: 23710-XXXXX

ECM-TCM: 23740-XXXXX

# TROUBLE DIAGNOSES

## Symptom Matrix Chart

### RELATION BETWEEN CONTROL ITEMS AND SENSORS/ACTUATORS

Control items		Fuel injection control			Ignition timing control	Idle speed control	Fuel pump drive control	Air conditioner cut control	Auxiliary electric fan control	Heated oxygen sensor heater control	Canister purge control	Variable valve timing control	Air jet swirl control RB20DE (L/B)	Variable air intake valve control (NA)	Turbo pressure control (T/C)	Self-diagnosis	Fail-safe	Engine, A/T, TCS/ABS integrated control		
		Fuel injection control	Air/fuel ratio feedback control	Fuel cut control																
Sensors	Crankshaft position sensor		⊙	⊙	⊙	⊙	⊙	⊙		⊙	○	⊙	⊙	⊙	○	○		○		
	Ring gear crankshaft position sensor [RB20DE (L/B)]		⊙											○						
	Mass air flow sensor		⊙	⊙	○	⊙						○	○	○	○	○	○	○	○	
	Engine coolant temperature sensor		○	⊙	○	○	○	○	T/C	⊙		○	○	○	○	○	○	○	○	
	Heated oxygen sensor			⊙						⊙	⊙						○	○		
	Knock sensor					○										○	○	○		
	Vehicle speed sensor			○	○		○		○			○	○				○	○	○	
	Throttle position sensor		○	○	⊙	○	○		⊙			○	○	○		○	○	○	○	
	Turbo pressure sensor (T/C)		○		○											○	○			
	Refrigerant pressure sensor						○		○	○										
	Ignition switch	START	⊙	○		○			○	○		○		○	○	○	○		○	
		IGN	⊙	⊙	⊙	⊙	⊙	⊙	○	○	○	○	○	○	○	○	○		○	
	Air conditioner switch				○		○		○	○		○								
	Park/neutral position switch		○	○	○	○	○						○						○	
	Power steering oil pressure switch						○		○											
	Electrical load switch						○													
	Battery voltage		○			○	○													
	Actuators	Injector		⊙	⊙	⊙													⊙	
		Ignition system	Power transistor				⊙											○		⊙
			Ignition coil				⊙													⊙
AAC valve						⊙														
Fuel pump relay								⊙												
Fuel pump								⊙												
ECM & IGN coil relay		⊙	⊙	⊙	⊙	⊙	⊙	⊙	⊙	⊙	⊙	⊙	⊙	⊙	⊙			⊙		
Auxiliary electric fan relay						○			⊙											
Air conditioner relay						○		⊙	○		○									
Canister purge control valve			○							⊙										
Variable valve timing control solenoid valve					○							⊙								
Variable air intake control solenoid valve (NA)														⊙						
Air jet swirl control solenoid valve [RB20DE (L/B)]		○			○													⊙		
Turbo pressure control solenoid valve (T/C)																⊙				
Others	FPCM (T/C)							○												
	Dropping resistor (T/C)								○											
	Air regulator						○													
	Canister			○													○			

# TROUBLE DIAGNOSES

## Symptom Matrix Chart (Cont'd)

### RELATION BETWEEN TROUBLE SYMPTOMS AND SENSORS

Sensors	Symptom	No start		Hard start		Rough idle				Poor drivability					Engine stall				Excessive fuel consumption	Can be detected by self-diagnosis	Can enter fail-safe mode						
		No combustion	With combustion	Cold engine	Hot engine	F idle not effective*	High idle	Low idle	Idle unstable when engine is cold	Idle unstable when engine is hot	Lack of power	Poor acceleration	Hesitation	Surging (during acceleration)	Surging (during cruising)	Knocking	Backfire	Afterburn				At idle	Driving	Deceleration	Load applied	Overheat	
Crankshaft position sensor (POS, REF)	Open	⊙																⊙	⊙	⊙	⊙			⊙			
	Instantaneous break			○	○				○	○		○	○	○	○				○	○	○	○			○		
Ring gear crankshaft position sensor [RB20DE (L/B)]	Open					○	○		○		○	○	○	○										○			
Mass air flow sensor	Signal	Open			○	○	⊙		○	○	○	○	○	○								○		○	⊙	⊙	
		High output			○	○			○	○	○	○	○	○	○				○	○	○	○		○			
		Low output			○	○			○	○	○	○	○	○	○	○				○	○	○	○		○		
	Ground	Open	⊙																⊙	⊙	⊙	⊙		⊙			
Power supply	Open			○	○	⊙		○	○	○	○	○	○	○							○		○	⊙	⊙		
Engine coolant temperature sensor	Open/short		○	○	○		○	○	○	○	○	○	○	○									○	⊙	⊙		
	High resistance		○	○	○		○		○	○	○	○	○	○				○	○	○	○		○				
	Low resistance		○	○	○		○	○		○	○	○	○	○	○			○	○	○	○	○	○	○	○	○	
Heated oxygen sensor	Open/short						○	○	○				○					○		○	○		○	○	○		
Knock sensor	Open/short									○	○												○	⊙	⊙		
	High output									○	○												○				
	Low output												○									○					
Vehicle speed sensor	Open/short																						○	○			
Throttle position sensor	Open/short				○	○	○		○	○	○	○	○	○	○			○		○	○		○	⊙	⊙		
	Unstable output					○		○		○	○		○							○							
	Poor adjustment					○																					
Turbo pressure sensor (T/C)	Open																						⊙				
Refrigerant pressure sensor	Open					○																	○				
	Short					○																	○				
Ignition switch (IGN)	Open	⊙																	⊙	⊙	⊙	⊙					
Ignition switch (START)	Open		○	○	○																						
Air conditioner switch	Open																										
Park/neutral position switch	Open			○	⊙	⊙	○	○																			
	Short				⊙																		○				
Power steering oil pressure switch	Open					○																	○				
	Short					○																	○				
Electrical load switch	Open																						○				
Multiplex communication line	Open/short																							⊙	⊙		
Control unit power supply	Open	⊙																	⊙	⊙	⊙	⊙					
Sensor ground	Open/short		○	○	○		○	○	○	○	○	○	○	○	○	○	○	○	○	○	○	○	○	○	○	○	○
Control unit and connector	Poor contact Water intrusion	○	○	○	○	○	○	○	○	○	○	○	○	○	○	○	○	○	○	○	○	○	○	○	○	○	○

\*: Fast idle

GI  
EC  
AT  
BR  
ST  
RS  
HA  
EL  
SD

# TROUBLE DIAGNOSES

## Symptom Matrix Chart (Cont'd)

Sensor-related problems		Symptom characteristics and inspection hints	
Crankshaft position sensor (POS, REF)	Open	Engine will not start when either REF signal circuit or POS signal circuit is open. Neither fuel system nor ignition system outputs control signals.	
	Instantaneous break	Symptoms vary with the break time and the vehicle's driving conditions. Light shock or surging will occur while the vehicle is being driven, and the engine will stall at idle speed.	
Ring gear crankshaft position sensor [RB20DE (L/B)]	Open	No air/fuel ratio compensation is carried out during lean burn status. Drivability may be affected.	
Mass air flow sensor	Signal	Open	Enters fail-safe mode. Driving under 2,400 rpm is allowed.
		High output	Air/fuel ratio becomes rich. Black smoke may be noted. Poor contact at the ground could be the cause.
		Low output	Air/fuel ratio becomes lean. Dirty hot wire or air entering the system could be the cause.
	Ground	Open	Air/fuel ratio becomes over-rich.
	Power	Open	Same symptom as when signal wire is open.
Engine coolant temperature sensor	Open/short	Enters fail-safe mode. Malfunction indicator lamp comes ON. Ordinary driving is allowed. Problems tend to occur when engine is cold or engine coolant temperature is high.	
	High resistance	Detects low engine coolant temperature. Problems tend to occur after engine warm-up.	
	Low resistance	Detects high engine coolant temperature. Problems tend to occur when engine is cold.	
Heated oxygen sensor	Open/short	Base air/fuel ratio is used.	
Knock sensor	Open/short	Ignition timing is retarded within the knock control range. Lack of power may be noted.	
	High output	Ignition timing is retarded within the knock control range. Lack of power may be noted.	
	Low output	Ignition timing may not be retarded when knock is detected.	
Vehicle speed sensor	Open/short	Fuel cut time becomes shorter, or no fuel cut is observed.	
Throttle position sensor	Open/short	Base idle speed is used. Fuel injection is not increased during acceleration. A/T shift point changes for A/T vehicles.	
	Unstable output	Unnecessary cut-in fuel injection could be the cause. Poor contact at the ground or control unit could be the cause.	
	Poor adjustment	Idle judgment is "OFF" while idling. Condition returns normal by turning the ignition switch ON and OFF repeatedly.	
Turbo pressure sensor (T/C)	Open	Turbo pressure is judged zero. No remarkable malfunction will be detected.	
Refrigerant pressure sensor	Open	Refrigerant pressure is judged high. Idle speed remains high while the air conditioner is ON.	
	Short	Refrigerant pressure is judged low. Idle speed remains low while the air conditioner is ON.	
Ignition switch (IGN)	Open	Engine will not start because neither fuel system nor ignition system outputs control signals.	
Ignition switch (START)	Open	Engine starts in normal condition. Engine may not start when temperature is extremely low.	
Air conditioner switch	Open	Air conditioner will not operate. No other malfunction will be noted.	
Park/neutral position switch	Open	Park/neutral position switch is judged "OFF". Target engine speed for cold engine in N or P position is reduced.	
	Short	Park/neutral position switch is judged "ON". Fast idle is effective when the engine is cold and the gear is in other than N and P positions. Vehicle excessively creeps.	
Power steering oil pressure switch	Open	Engine may stall when the steering wheel is turned while the vehicle is standstill and the accelerator pedal is lightly pressed, or when the steering wheel is turned during deceleration.	
	Short	Power steering switch is judged "ON." Value will be compensated constantly.	
Electrical load switch	Open	Idle speed drops so that the engine can stall when electrical load is applied.	
Multiplex communication line	Open/short	Torque reduction control is not performed. Therefore, shift shock becomes greater.	
Control unit power supply	Open	Engine will not start because neither fuel system nor ignition system outputs control signals.	
Sensor ground	Open/short	Same symptoms as when sensor harness is open.	
Control unit and connector	Poor contact Water intrusion	In case of poor contact, the connector fitting may be loose. In case of water intrusion, the engine stalls and become inoperative for a while. The engine may restart soon in some cases.	

# TROUBLE DIAGNOSES

## Symptom Matrix Chart (Cont'd)

### RELATION BETWEEN TROUBLE SYMPTOMS AND ACTUATORS

Actuators	Symptom	No start		Hard start		Rough idle				Poor drivability						Engine stall				Excessive fuel consumption	Can be detected by self-diagnosis	Can enter fail-safe mode			
		No combustion	With combustion	Cold engine	Hot engine	F idle not effective*	High idle	Low idle	Idle unstable when engine is cold	Idle unstable when engine is hot	Lack of power	Poor acceleration	Hesitation	Surging (during acceleration)	Surging (during cruising)	Knocking	Backfire	Afterburn	At idle				Driving	Deceleration	Load applied
Injector	Power supply	○	○	○	○				⊙	⊙	○	○	○	○	○			○	○	○	○		○		
	Coil	○	○	○	○				⊙	⊙	○	○	○	○	○			○	○	○	○		○		
	Drive circuit	Open	○	○	○	○			○	⊙	⊙	○	○	○	○			○	○	○	○		○		
		Short	○	○	○	○				⊙	⊙	○	○	○	○			○	○	○	○		○		
	Injection port	Foreign material	○	○	○	○				⊙	⊙	○	○	○	○			○	○	○	○		○		
		Clogs	○	○	○	○				⊙	⊙	○	○	○	○	○	○		○	○	○	○		○	
Ignition signal (Power transistor drive signal)	Open	⊙						○			○	○	○	○	○		○	⊙	⊙	⊙	⊙		○	⊙	
Ignition primary signal (Power transistor ground)	Open	⊙						○			○	○	○	○	○		○	⊙	⊙	⊙	⊙		○	⊙	
Ignition coil	Power supply	⊙									○	○	○	○	○		○	⊙	⊙	⊙	⊙		○	⊙	
	Primary side	⊙									○	○	○	○	○		○	⊙	⊙	⊙	⊙		○	⊙	
	Secondary side	Open	⊙									○	○	○	○		○	⊙	⊙	⊙	⊙		○		
		Leaks	○	○	○	○				○	○	○	○	○	○			○	○	○	○	○		○	
AAC valve	Power supply					○	○	○		○								○		○	○				
	Drive circuit					○	○	○		○								○		○	○				
Fuel pump relay	Open	⊙											○	○				⊙	⊙	⊙	⊙				
Auxiliary electric fan relay [RB25DE, RB25DET]	Open														○							○			
Canister purge control valve	Open																						○		
	Short			○	○				○	○	○	○		○				○		○	○		○		
Variable valve timing control solenoid valve	Open										○	○			○								○		
Variable air intake control solenoid valve (NA)	Open										○	○													
	Short										○	○													
Air jet swirl control solenoid valve [RB20DE (L/B)]	Open										○	○	○												
	Short					○													○				○		
Turbo pressure control solenoid valve (T/C)	Open										○	○													
Injector ground (Total ground)	Open	⊙																⊙	⊙	⊙	⊙				
	Instantaneous break								○	○				○	○			○	○	○	○				

\*: Fast idle

GI

EC

AT

BR

ST

RS

HA

EL

SD

# TROUBLE DIAGNOSES

## Symptom Matrix Chart (Cont'd)

Actuator-related malfunction			Symptom characteristics and inspection hints
Injector	Power supply	Open	An open circuit causes no fuel injection to the corresponding cylinder, and the heated oxygen sensor output becomes lean. When the open circuits are observed at all cylinders, the engine will not start.
	Coil	Open	
	Drive circuit	Open	
		Short	A short circuit causes continuous fuel injection to the corresponding cylinder, and over-rich air/fuel ratio and misfire will be noted. When the short circuits are observed at all cylinders, the engine will not start.
	Injection port	Foreign material	Foreign material causes continuous fuel injection to the corresponding cylinder.
Clogs		Symptoms vary with the condition how the injection port is clogged. Air/fuel ratio compensation factor becomes larger. (110 to 125%)	
Ignition signal (Power transistor drive signal)		Open	<ul style="list-style-type: none"> <li>● An open circuit causes no fuel injection to the corresponding cylinder, and the heated oxygen sensor output becomes lean.</li> <li>● When the open circuits are observed at all cylinders, the engine will not start.</li> <li>● In case of instantaneous break, symptoms vary with the break time and the vehicle's driving conditions. Light shock or surging will occur while the vehicle is being driven.</li> <li>● The engine will stall when break time is long.</li> </ul>
Ignition primary signal (Power transistor ground)		Open	
Ignition coil	Power supply	Open	
	Primary side	Open	
	Secondary side	Open	
Leaks			
AAC valve	Power supply	Open	AAC valve is fully closed. Symptoms vary with the base engine speed. When it is too low, engine may stall while the vehicle is decelerating or when the power steering load or electrical load is applied.
	Drive circuit	Open	
Fuel pump relay		Open	Engine will not start. In case of instantaneous break, surging may occur.
Auxiliary electric fan relay [RB25DE, RB25DET]		Open	Auxiliary electric fan will not operate even after warm-up is completed.
Canister purge control valve	Open		The valve will not purge. Gasoline smell may be noted when the weather is hot.
	Short		The valve purges constantly. In summertime, engine may stall at idle speed due to rich air/fuel ratio. In wintertime, various malfunctions may occur due to lean air/fuel ratio.
Variable valve timing control solenoid valve		Open	Valve timing not switched.
Variable air intake control solenoid valve (NA)	Open		Variable air intake valve opens, and torque in low speed range is reduced.
	Short		Variable air intake valve closes, and torque in high speed range is reduced.
Air jet swirl control solenoid valve [RB20DE (L/B)]	Open		Air jet swirl control valve remains closed.
	Short		Air jet swirl control valve remains open.
Turbo pressure control solenoid valve (T/C)		Open	Swing valve opens earlier, and maximum turbo pressure is reduced.
Injector ground (Total ground)	Open		Engine will not start because the injectors do not operate.
	Instantaneous break		Symptoms vary with the break time and the vehicle's driving conditions. Surging or engine stall may occur when the instantaneous break occurred during fuel injection.

# TROUBLE DIAGNOSES

## Symptom Matrix Chart (Cont'd)

### RELATION BETWEEN TROUBLE SYMPTOMS AND ENGINE MECHANICAL/ACCESSORIES

Malfunction of the gasoline engine will not occur when the three elements of combustion (compression pressure, air/fuel mixture, and spark) are all normal. Though the air/fuel mixture and the spark (ignition timing) are controlled by ECM (TCM) control unit, if the engine mechanical is malfunctioning, a malfunction will occur. (The table below shows universal cases. Some cases may not apply to the vehicle.)

	No start		Hard start		Rough idle				Poor drivability						Engine stall			Excessive fuel consumption						
	No combustion	With combustion	Cold engine	Hot engine	F idle not effective*	High idle	Low idle	Idle unstable when engine is cold	Idle unstable when engine is hot	Lack of power	Poor acceleration	Hesitation	Surging (during acceleration)	Surging (during cruising)	Knocking	Backfire	Afterburn		At idle	Driving	Deceleration	Load applied	Overheat	
Engine mechanical-related malfunction																								
⊙: High possibility																								
○: Medium possibility																								
△: Low possibility																								
Air/fuel mixture	Air sucked in at oil level gauge							○	△		○	○						△				△	△	
	Air sucked in at oil filler cap							○	△		○	○						△				△	△	
	Loose air duct (A-F/M downstream)			○	△			○	△	○	○	○	○	○	△	△		○	○			○	△	
	Misconnection of canister piping			○	△		△	○	△		○	○	○	○				○	○			○	△	
	Cracked intake manifold			○	△			○	△	○	○	○	○	○	△	△		○	○			○	△	
	PCV valve stuck open					○		○	△		○	○	○	○									○	
	Clogged fuel strainer			○	△			○	△	○	○	○	○	○	○	○		△	○			△		
	Clogged air cleaner element									○	○	○	○	○									○	
	Malfunctioning pressure regulator	△	○	○	○			○	○	○	○	○	○	○				○	○	○	○			
	Improper gasoline properties	△	○	○	○			○	○	○	○	○	○	○	○	○		○	○			○		
	EGR valve stuck open			○	○			○	○	○	○	○	○	○				○	○	○	○		△	
	Deposits on valve			○	○			○	△	○	○	○	○	○	○	○		○	○	○	○		△	
Excessive canister purge volume							△	○	○	○	○	○	○				○		○	○		△		
Spark	Misconnection of high-tension wire			⊙	⊙			⊙	⊙	⊙	⊙	⊙	⊙				⊙	⊙	⊙	⊙	⊙	⊙		
	Improperly adjusted ignition timing			○	○			○	○	○	○	○	○	○	○	○		○	△	○	○		○	
	Malfunctioning spark plug			○	○			○	○	○	○	○	○	○				△		△	△			
	High-tension wire leaks	△	○	○	○			○	○	○	○	○	○	○				○	○	○		○	○	
	Distributor cap leaks	△	○	○	○			○	○	○	○	○	○	○				○	○	○		○	○	
Compression pressure	Improper valve contact	△	○	⊙	⊙			⊙	⊙	⊙	⊙	⊙	⊙				○	○	○	○				
	Worn piston ring	△	○	⊙	⊙			⊙	⊙	⊙	⊙	⊙	⊙				○	○	○		○			
Others	Clogged catalytic converter or exhaust system		△	○	○			○	○	○	○	○	○				○	○	○	○		○		
	Low base idle speed			△	△			△	△									○	○	○	○			
	Dragging brake									○	○	○											○	
	Belt tension too high																	○	○	○	○		○	
	Air conditioner load too heavy							○	○	△	△	△	△	△				○	△	○	○		○	
	A/T load too heavy										△							△		○	△		○	
	Foreign material (vinyl, etc.) in fuel tank	△	○	○	○			○	○	○	○	○	○	○				○	○	○	○			
Clogged radiator or capacitor																						○		

- \*: Fast idle  
 Adding to the items listed above, check the following.
- Wiring harness for tension
  - Ground wires for loosenes
  - Fluids and oils for levels
  - All connectors for connection
  - Battery connections for loosenes and corrosion
  - Drive belts for loosenes

GI  
**EC**  
 AT  
 BR  
 ST  
 RS  
 HA  
 EL  
 SD



# TROUBLE DIAGNOSES

## Symptom Matrix Chart (Cont'd)

Engine mechanical-related malfunction	Symptom characteristics and inspection hints	
Air/fuel mixture	Air sucked in at oil level gauge	<ul style="list-style-type: none"> <li>● Air/fuel ratio becomes lean.</li> <li>●● Air/fuel ratio compensation factor becomes higher.</li> <li>● Intake manifold induction vacuum becomes lower.</li> </ul> **Use an induction vacuum (pressure) gauge for check. * Common to all air sucking conditions from air intake system.
	Air sucked in at oil filler cap	
	Loose air duct (A-F/M downstream)	
	Misconnection of canister piping	
	Cracked intake manifold	
	PCV valve stuck open	Abnormal noise (peep) may be heard.
	Clogged fuel strainer	Symptoms vary with the condition how they are clogged. However, the symptoms tend to occur when the vehicle is driving at high speed and under high load.
	Clogged air cleaner element	
	Malfunctioning pressure regulator	Various symptoms occur depending on the fuel pressure.
	Improper gasoline properties	Various symptoms occur depending on the properties.
	EGR valve stuck open	
	Deposits on valve	Air/fuel ratio becomes lean. Air/fuel ratio compensation factor becomes higher.
Excessive canister purge volume	Engine may stall when the accelerator pedal is lightly pressed. (Especially in summertime.)	
Spark	Misconnection of high-tension wire	Check if the ignition timing is correct.
	Improperly adjusted ignition timing	
	Malfunctioning spark plug	
	High-tension wire leaks	Symptoms vary with the degree of leaks.
	Distributor cap leaks	
Com- pression pressure	Improper valve contact	Symptoms vary with the degree of contact and the number of cylinders.
	Worn piston ring	Symptoms vary with the degree of wear and the number of cylinders.
Others	Clogged catalytic converter or exhaust system	In many cases, engine stalls and then restarts after a while.
	Low base idle speed	Engine may stall while the vehicle is decelerating or when the power steering load or electrical load is applied.
	Dragging brake	
	Belt tension too high	
	Air conditioner load too heavy	Too much refrigerant in the system.
	A/T load too heavy	Insufficient A/T fluid (FR model)
	Foreign material (vinyl, etc.) in fuel tank	Symptom tends to occur when fuel level in the tank becomes lower.
Clogged radiator or capacitor		

## Idle Speed Inspection and Adjustment

### Idle speed specification (After warm-up)

Engine type	RB20DE (L/B)	RB25DE	RB25DET
Idle speed [N or P position] (Air conditioner ON)	650±50 (700 - 900)*		
Base idle speed (Feedback control cancelled) (rpm)	600		
Ignition timing (BTDC°/rpm) (Feedback control cancelled)	10±2/600	15±2/600	
CO density (%)	0.1, max.		
HC density (ppm)	50, max.		

\*: Idle speed varies with air conditioner refrigerant pressure and engine coolant temperature.

- ① • Warm up engine to normal operating temperature.
- ① • Connect "CONSULT" to the data link connector for CONSULT (under the instrument lower driver panel) and turn ignition switch ON.
- ⓧ • Connect a tachometer to the engine speed detection terminal.
- ⓧ • Check that the air conditioner load, power steering pump load, and various electrical loads are not applied to the engine. During inspection and adjustment, the A/T selector lever must be in "N" or "P" position.
- ① • Perform "IACV-AAC VALVE ADJ" in "WORK SUPPORT" mode with CONSULT.
- ⓧ • Disconnect throttle position sensor harness connector.

(Above step cancels the idle speed feedback control.)

- Turn idle speed adjusting screw (IAS) on the AAC valve assembly to adjust base idle speed to 600 rpm.
- Turning IAS clockwise makes base idle speed lower. Turning IAS counterclockwise makes base idle speed higher.
- ① • Cancel "IACV-AAC VALVE ADJ" in "WORK SUPPORT" mode with CONSULT.
- ⓧ • Connect throttle position sensor harness connector.
- Check that the actual idle speed is 650±50 rpm.

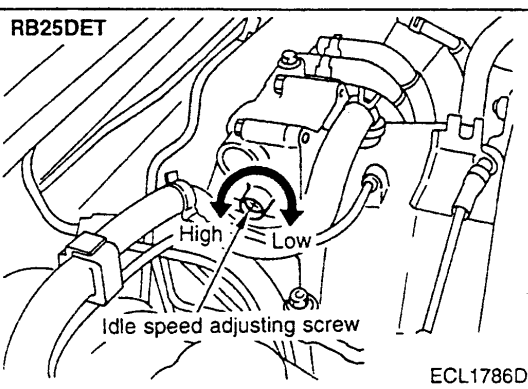
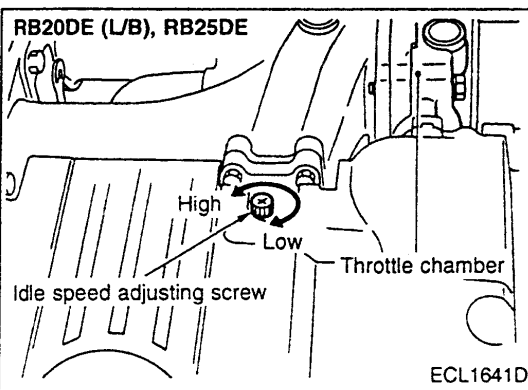
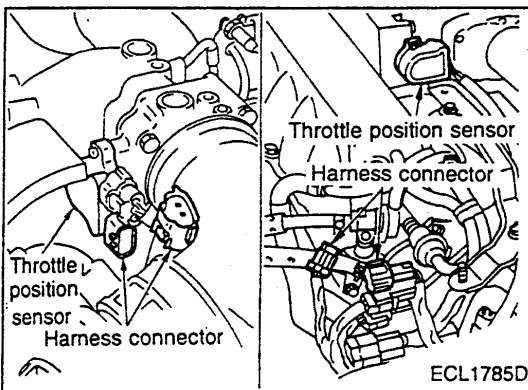
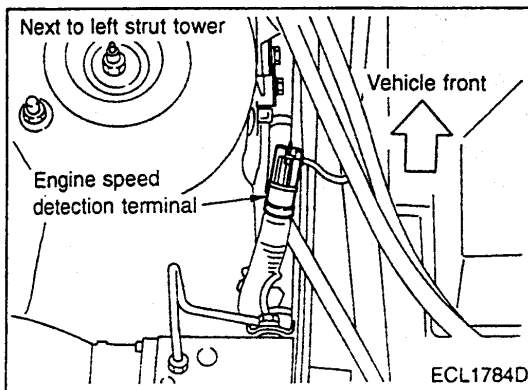
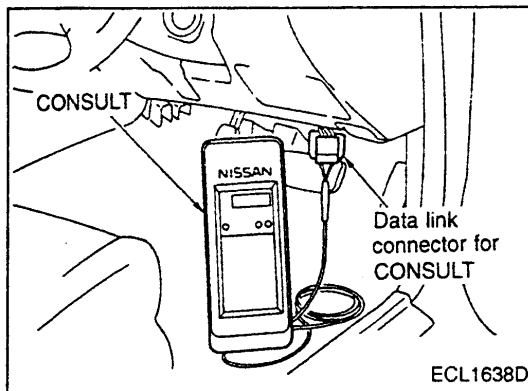

# TROUBLE DIAGNOSES

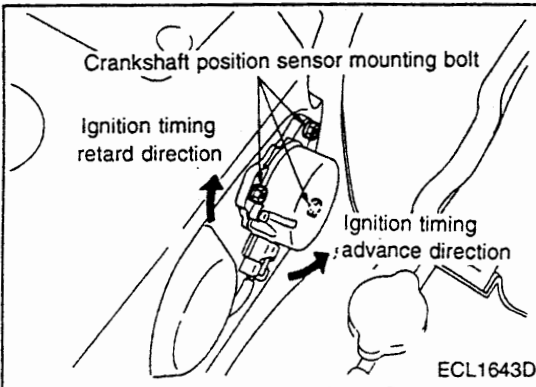
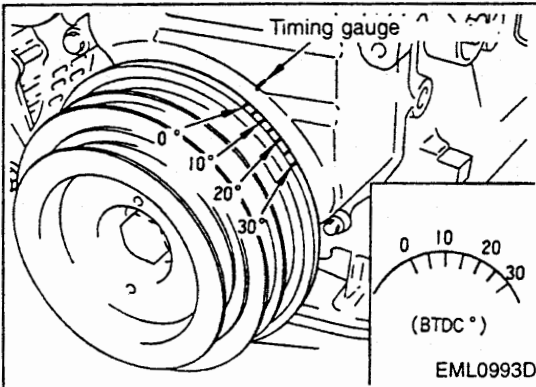
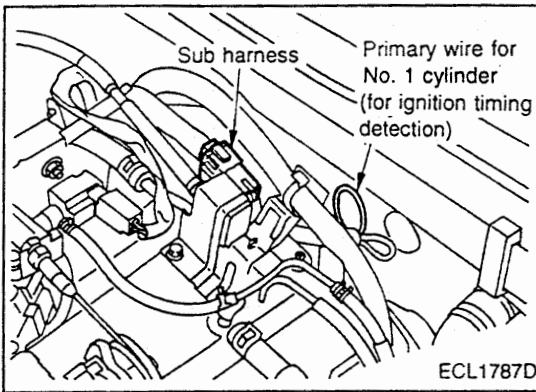

## Ignition Timing Inspection and Adjustment

- Install a timing light to the ignition timing detection loop (blue).
- Perform "IACV-AAC VALVE ADJ" in "WORK SUPPORT" mode with CONSULT.
- Disconnect throttle position sensor harness connector.

(Above step cancels the idle speed and ignition timing feedback controls.)

- With the engine idling, check that the ignition timing and base idle speed is within the specification listed below.
- If not within the specifications, loosen the crankshaft position sensor mounting bolt, turn the crankshaft position sensor and adjust the ignition timing to the specifications. Turning the crankshaft position sensor counterclockwise advances the ignition timing.

Unit: BTDC°/rpm

Engine type	RB20DE (L/B)	RB25DE, RB25DET
Ignition timing	10±2/600	15±2/600

- Cancel "IACV-AAC VALVE ADJ" in "WORK SUPPORT" mode with CONSULT.
- Connect throttle position sensor harness connector.
- Race engine and check that the ignition timing advances immediately.

### CAUTION:

When idle speed or ignition timing is checked and adjusted with the throttle position sensor harness connector disconnected, the self-diagnostic results of the throttle control unit and the ABS must be erased. To erase the self-diagnostic results, first turn ignition switch OFF, and then start the engine. Confirm that the TCS OFF indicator lamp, 4WD indicator lamp, and ABS indicator lamp are all OFF, then erase the self-diagnostic results. This must be done because disconnection of the throttle position sensor harness connector, even for engine adjustment, will make control units to detect abnormal status.

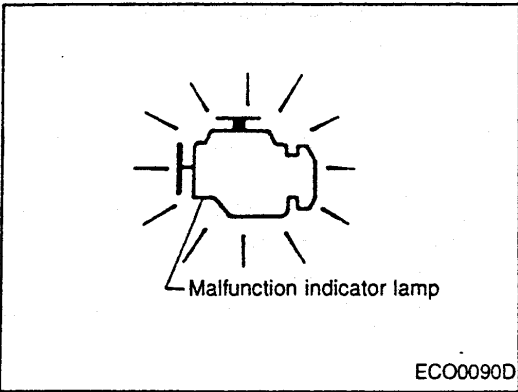
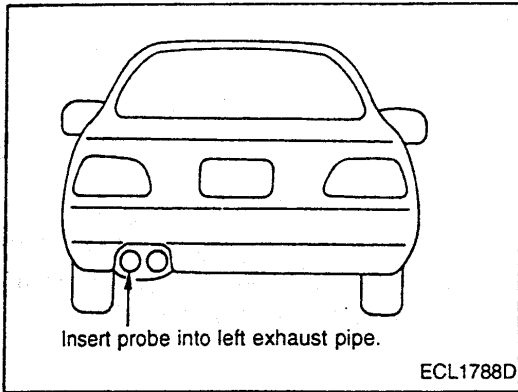

## Air/Fuel Ratio Inspection

### CO/HC DENSITY INSPECTION

The vehicle uses air/fuel ratio feedback system with learning function. Because wide range of compensation is available, no CO/HC density adjustment is necessary.

- Warm up engine to normal operating temperature, and check that the idle speed and the ignition timing are within the specifications. Then, check CO/HC density with CO/HC meter.

#### CAUTION:

**RB25DET·A/T model uses exhaust pressure-sensitive control muffler. Therefore, insert probe of the CO/HC meter into the left exhaust pipe. (Under no-load condition, exhaust gas is emitted from the left exhaust pipe only.)**

- If not within the specifications, check the air/fuel ratio feedback status as follows.

- Select "M/R F/C MNT" in "DATA MONITOR" mode.
- Run engine at approx. 2,000 rpm or higher and check that "RICH" and "LEAN" are displayed alternately.
- Turn ignition switch ON and connect terminals CHK and IGN on the data link connector for CONSULT (under instrument lower driver panel) for 2 seconds or more with a suitable harness, then disconnect them.
- Warm up the engine to normal operating temperature, then run the engine at 2,000 rpm or higher. Check that the malfunction indicator lamp blinks at least five times in 10 seconds.
- Engine speed should be increased (approx. 2,000 rpm) before performing check, even though the air/fuel ratio feedback control is active during idling.

GI

EC

AT

BR

ST

RS

HA

EL

SD

## Fuel Pressure Inspection

### QUICK INSPECTION

- ① ● Turn ignition switch ON (engine not running).
- Select "FUEL PUMP CIRCUIT" in "FUNCTION TEST" mode.
- Pinch fuel hose with fingers and check for pulsation.
- ② ● Pinch fuel hose between fuel filter and fuel gallery (fuel damper for RB25DET model) with fingers while fuel pump is operating. Hose should feel hard or pulsating.

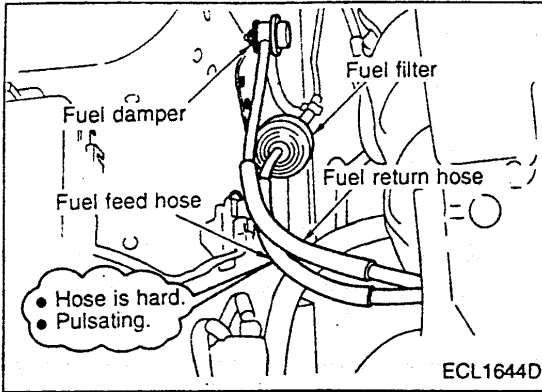

### INSPECTION USING FUEL PRESSURE GAUGE

#### Releasing fuel pressure

- ① ● Start engine.
- Select "FUEL PRESSURE RELEASE" in "WORK SUPPORT" mode.
- Touch "START" and after engine stalls, crank it two or three times to release all fuel pressure.
- ② ● Start engine and disconnect fuel pump fuse.
- After engine stalls, crank it two or three times to release all fuel pressure.

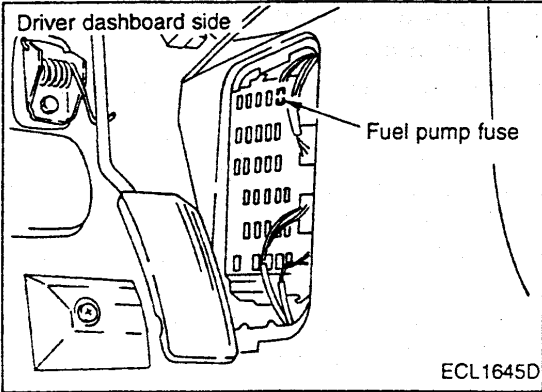

#### Installing fuel pressure gauge

- Connect a fuel pressure gauge between fuel filter and fuel gallery (fuel damper for RB25DET model).

#### CAUTION:

When disconnecting fuel hose, use shop cloth to remove any fuel leaks.

- Install fuel pump fuse.

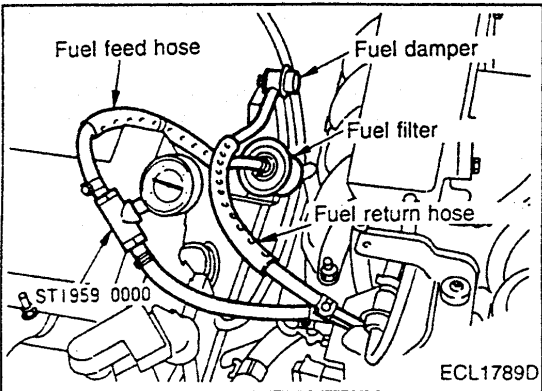

#### Fuel pressure standard value confirmation

- Start engine and check that the fuel pressure is as specified.
  - Fuel pressure [MPa (kg/cm<sup>2</sup>)]**
  - At idle: 0.25 (2.5)**
  - When vacuum hose is disconnected from pressure regulator: 0.29 (3.0)**
- If the vehicle shows poor starting, check fuel pressure for approx. 5 seconds after ignition switch is turned ON (During 3 sec. after ignition switch turned ON for RB25DET model).
  - Fuel pressure [MPa (kg/cm<sup>2</sup>)]**
  - During 5 sec. after ignition switch turned ON: 0.29 (3.0)**
- When fuel pressure is NG
  - Too high: Malfunctioning pressure regulator, malfunctioning fuel damper, clogged fuel return line, bent hose
  - Too low: Malfunctioning pressure regulator, malfunctioning fuel damper, poor fuel pump discharging, clogged fuel supply line, clogged fuel filter

#### CAUTION:

Also check fuel pressure at increased engine speed.

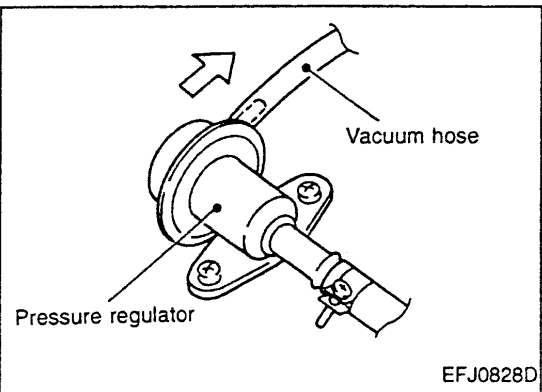

# TROUBLE DIAGNOSES

## ECM (.TCM) Input/Output Signal Reference Value

### SIGNAL VOLTAGES MEASURED WITH OSCILLOSCOPE AND CIRCUIT TESTER

- Signal voltages measured at ECM (.TCM) terminals (terminals for engine control) with a circuit tester and example of waveforms displayed on an oscilloscope are shown below.
- For signal terminals for A/T control, refer to "A/T Trouble Diagnosis" in AT section.

Measured data are affected by many factors such as irregularity of parts, vehicle history, operating conditions, environment, service status, and measuring instruments and methods.

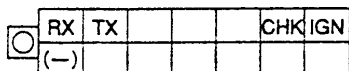
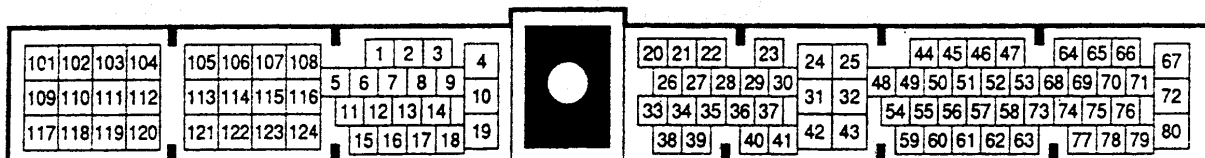

(Data link connector for CONSULT)

ECQ0357D

Terminal No.	Signal name	At idle	At approx. 2,000 rpm
1 2 3 7 8 9	Ignition signal (Power transistor drive signal)	<p>When cranking: Approx. 0.12V</p> <p>At idle: Approx. 0.1V</p>	<p>Approx. 0.15 - 0.25V</p>
4	ECM & IGN coil relay control signal	<p>Approx. 1V (During approx. 1.5 sec. after ignition switch turned OFF: Approx. 1V 1.5 sec. after ignition switch turned OFF: Battery voltage)</p>	←
5	Tachometer drive signal	<p>[RB20DE (L/B), RB25DE] Approx. 1.2V</p>	<p>Approx. 3V</p>
		<p>[RB25DET] Approx. 7.2V</p>	<p style="text-align: center;">←</p>

NOTE: Above voltages are measured values obtained by analog circuit tester.

GI

EC

AT

BR

ST

RS

HA

EL

SD

## TROUBLE DIAGNOSES

### ECM (·TCM) Input/Output Signal Reference Value (Cont'd)

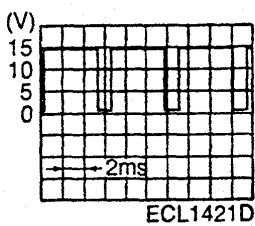
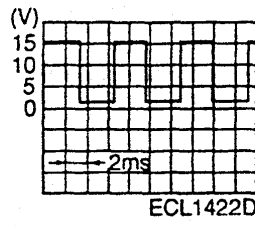
Terminal No.	Signal name	At idle	At approx. 2,000 rpm
11	AAC valve control signal	<p style="text-align: center;">Approx. 12V</p>  <p style="text-align: center;">ECL1421D</p>	<p style="text-align: center;">Approx. 8V</p>  <p style="text-align: center;">ECL1422D</p>
13	Fuel pump relay control signal	[RB20DE (L/B), RB25DE] During 5 sec. after ignition switch turned ON: Approx. 0.25V 5 sec. after ignition switch turned ON: Battery voltage When cranking: Approx. 0.25V At idle: Approx. 0.25V	Approx. 0.25V
		[RB25DET] During 3 sec. after ignition switch turned ON: Approx. 0.9V 3 sec. after ignition switch turned ON: Battery voltage When cranking: Approx. 0.9V At idle: Approx. 0.9V	Approx. 0.9V
14	Air conditioner relay control signal	Air conditioner OFF: Battery voltage Air conditioner ON: Approx. 0.25V	←
17	Malfunction indicator lamp	MIL OFF: Battery voltage MIL ON RB20DE (L/B), RB25DE: Approx. 0.85V RB25DET: Approx. 0.1V	←
20	Ignition switch (START) signal	Approx. 0V (Ignition switch at START: Battery voltage)	←
21	Air conditioner switch signal	Air conditioner OFF: Approx. 4.7V Air conditioner ON: Approx. 0.1V	←
22 (CHK)	Check (Diagnosis start)	CONSULT connected: Approx. 0V CONSULT not connected: Approx. 0V	←
23	Throttle position sensor signal	Accelerator pedal released: Approx. 0.5V Accelerator pedal fully depressed: Approx. 4.2V (Ignition switch ON, engine not running)	Approx. 0.6 - 0.7V
24 (IGN)	Ignition switch (IGN) signal	Ignition switch OFF: Approx. 0V Ignition switch ON: Battery voltage	←
25, 32 43 116 124	Ground	Approx. 0V	←
26	Power steering oil pressure switch signal	Steering wheel not turned: Approx. 4.7V Steering wheel turned: Approx. 0V	←

NOTE: Above voltages are measured values obtained by analog circuit tester.

# TROUBLE DIAGNOSES

## ECM (TCM) Input/Output Signal Reference Value (Cont'd)

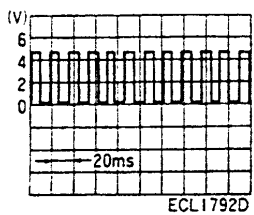
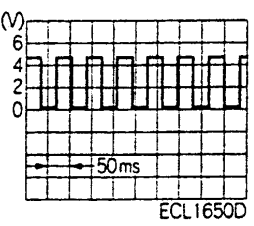
Terminal No.	Signal name	At idle	At approx. 2,000 rpm
29	Vehicle speed sensor signal	Approx. 4.7V or approx. 0V (when parked)	[RB20DE (L/B)] When driving at approx. 40 km/h: Approx. 2.4V 
			[RB25DE, RB25DET] When driving at approx. 40 km/h: Approx. 2.4V 
30	Head lamp switch signal	Light switch OFF: Approx. 0V Light switch ON: Battery voltage	←
31	Ignition power supply	Ignition switch OFF: Approx. 0V Ignition switch ON: Battery voltage	←
33	Idle position switch signal [RB20DE (L/B), RB25DET-A/T]	Battery voltage	Approx. 0V (When accelerator pedal is depressed)
37	Throttle opening signal [RB25DE-4WD-M/T, RB25DE-A/T, BR25DET]	Accelerator pedal released: Approx. 0.5V Accelerator pedal fully depressed: Approx. 4.2V (Ignition switch ON, engine not running)	Approx. 0.7V
39	Neutral signal (Park/Neutral position switch)	Selector lever in Neutral or in N or P position: Approx. 0V Selector lever in other positions: Approx. 4.8V	←
41	Full switch signal [RB20DE (L/B), RB25DET-A/T]	Accelerator pedal released: Approx. 0V Accelerator pedal fully depressed: Battery voltage (Ignition switch ON, engine not running)	←

GI  
**EC**  
 AT  
 BR  
 ST  
 RS  
 HA  
 EL  
 SD

NOTE: Above voltages are measured values obtained by analog circuit tester.



# TROUBLE DIAGNOSES

## ECM (TCM) Input/Output Signal Reference Value (Cont'd)

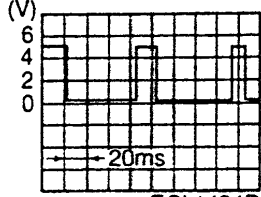
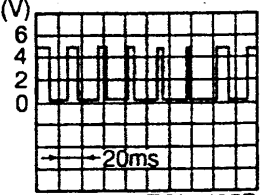
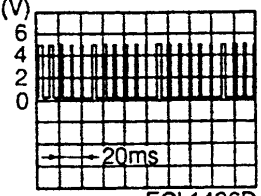
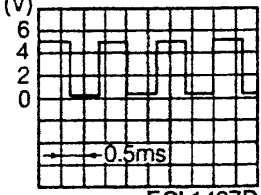
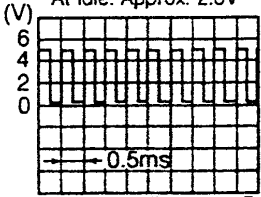
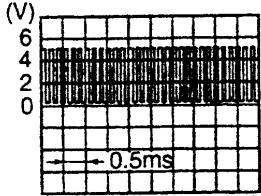
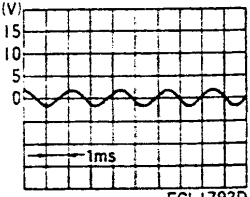
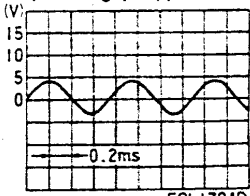
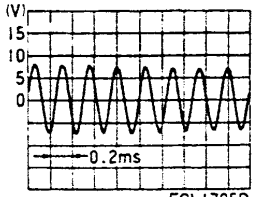
Terminal No.	Signal name	At idle	At approx. 2,000 rpm
44 45	Crankshaft position sensor 120° (REF) signal	<p>When cranking: Approx. 1.3V</p>  <p style="text-align: center;">ECL1424D</p> <p>At idle: Approx. 1.35 - 1.4V</p>  <p style="text-align: center;">ECL1425D</p>	<p>Approx. 1.4V</p>  <p style="text-align: center;">ECL1426D</p>
46	Crankshaft position sensor 1° (POS) signal	<p>When cranking: Approx. 2.6V</p>  <p style="text-align: center;">ECL1427D</p> <p>At idle: Approx. 2.6V</p>  <p style="text-align: center;">ECL1428D</p>	<p>Approx. 2.6V</p>  <p style="text-align: center;">ECL1429D</p>
47	Ring gear crankshaft position sensor signal [RB20DE (L/B)]	<p>When cranking (DC range): Approx. 0.1V (AC range): Approx. 0.5V</p>  <p style="text-align: center;">ECL1793D</p> <p>At idle (DC range): Approx. 0.1V (AC range): Approx. 1.3V</p>  <p style="text-align: center;">ECL1794D</p>	<p>DC range: Approx. 0.1V AC range: Approx. 3.2V</p>  <p style="text-align: center;">ECL1795D</p>
	Turbo pressure sensor signal [RB25DET]	Approx. 2.7V	← (When engine raced suddenly: Approx. 2.7 - 3.1V)
48	Throttle position sensor, refrigerant pressure sensor, turbo pressure sensor power supply	Approx. 5.2V	←
49	Rear defogger switch signal	Rear defogger switch OFF: Approx. 0V Rear defogger switch ON: Battery voltage	←

NOTE: Above voltages are measured values obtained by analog circuit tester.

# TROUBLE DIAGNOSES

## ECM (TCM) Input/Output Signal Reference Value (Cont'd)

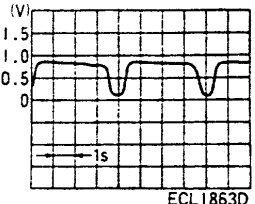
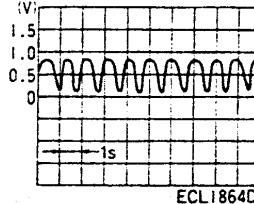
Terminal No.	Signal name	At idle	At approx. 2,000 rpm
50	Heated oxygen sensor signal	Fluctuates between approx. 0.1 to 0.4V and approx. 0.7 to 0.9V 	
51	Throttle motor sensor signal [RB25DET]	Approx. 3.4V	← (Voltage becomes lower when TCS operates.)
53	Motor throttle switch signal [RB25DET]	Approx. 4.7V	← (When TCS is operating: Approx. 0V)
54	Mass air flow sensor signal	Ignition switch ON: Approx. 0.2V At idle: Approx. 1.1 - 1.2V	Approx. 1.6 - 1.7V
55	Mass air flow sensor ground	Approx. 0V	←
56	Engine coolant temperature sensor signal	Coolant temperature approx. 20°C: Approx. 3.5V Coolant temperature approx. 80°C: Approx. 1.2V	←
57	Refrigerant pressure sensor	Approx. 0.36V min. (Voltage increases as the air conditioner refrigerant pressure increases.)	←
62	Knock sensor signal 1	Approx. 0.4 - 2V (*)	←
63	Knock sensor signal 2	*: Voltage varies with measuring range (internal resistance) of a circuit tester.	
67 72	Control unit power supply	Battery voltage	←
75 (RX)	Receive (Data input to control unit)	CONSULT connected: Approx. 0.25V CONSULT not connected: Battery voltage	←
76 (TX)	Transmit (Data output from control unit)	CONSULT connected: Approx. 9V max. CONSULT not connected: Approx. 0V	←
78	Auxiliary electric fan relay control signal [RB25DE, RB25DET]	Fan stopped: Battery voltage Fan operating: Approx. 0.2 - 0.3V	←

GI

EC

AT

BR

ST

RS

HA

EL

SD

NOTE: Above voltages are measured values obtained by analog circuit tester.

# TROUBLE DIAGNOSES

## ECM (·TCM) Input/Output Signal Reference Value (Cont'd)

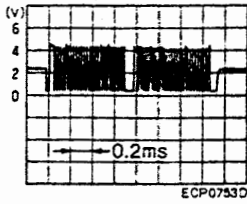
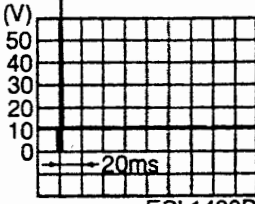
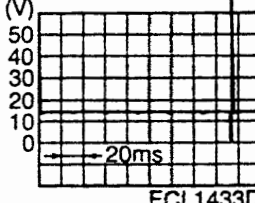
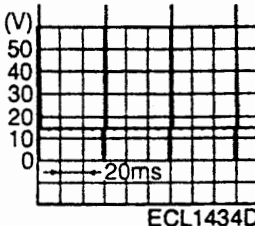
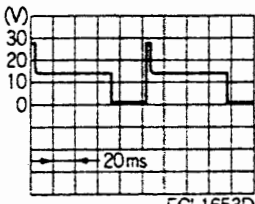
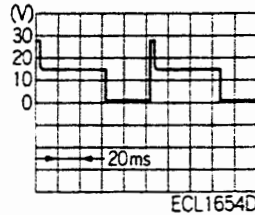
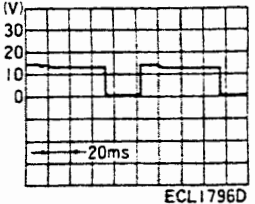
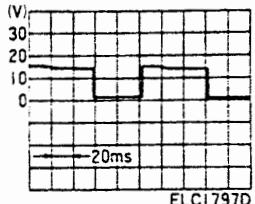
Terminal No.	Signal name	At idle	At approx. 2,000 rpm
79	ECM-TCM, TCS/ABS integrated control signal [Multiplex communication] [RB25DE-A/T, RB25DET]	At idle Approx. 2V 	←
80	Battery power supply	Battery voltage	←
101 103 105 110 112 114	Injector drive signal	When cranking: Approx. 10.5V  At idle: Battery voltage 	Slightly lower than battery voltage 
104	Variable air intake control solenoid valve control signal [RB20DE (L/B), RB25DE] Turbo pressure control solenoid valve control signal [RB25DET]	Ignition switch ON: Battery voltage (Solenoid valve OFF) At idle: Approx. 0.2 - 0.3V (Solenoid valve ON)	← At approx. 3,650 rpm and above [RB20DE (L/B)] At approx. 3,500 rpm and above [RB25DE] : Battery voltage (Solenoid valve OFF)
107	Air jet swirl control solenoid valve control signal [RB20DE (L/B)]	Coolant temperature below approx. 70°C: Approx. 0.9V (Solenoid valve ON) Coolant temperature approx. 70°C and above: Battery voltage (Solenoid valve OFF)	← Coolant temperature approx. 70°C and above, and driving at approx. 3,300 rpm and above [M/T] Coolant temperature approx. 70°C and above, and driving at approx. 3,000 rpm and above [A/T] : Approx. 0.9V (Solenoid valve ON)
108	Canister purge control valve control signal	[RB20DE (L/B), RB25DE] Air conditioner OFF: Battery voltage Air conditioner ON: Battery voltage → Approx. 10V (After approx. 15 sec.)  (Waveform indicates when air conditioner is ON.)	Approx. 9V 
108	Canister purge control valve control signal	[RB20DET] Air conditioner OFF: Battery voltage Air conditioner ON: Battery voltage → Approx. 10V (After approx. 15 sec.)  (Waveform indicates when air conditioner is ON.)	Approx. 9V 

NOTE: Above voltages are measured values obtained by analog circuit tester.

# TROUBLE DIAGNOSES

## ECM (·TCM) Input/Output Signal Reference Value (Cont'd)

Terminal No.	Signal name	At idle	At approx. 2,000 rpm
109	Control unit power supply (Counter-electromotive current feedback circuit)	Battery voltage	←
111	Fuel pump terminal voltage control output signal [RB25DET]	Ignition switch at START: Approx. 0V During approx. 30 sec. after engine started with coolant temperature 50°C or above: Approx. 0V At idle: Approx. 10V	Approx. 0V
117	Variable valve timing control solenoid valve control signal	Battery voltage (Solenoid valve OFF)	← [With driving wheels lifted and gear in D position: Approx. 0.45V (Solenoid valve ON)]
118	Heated oxygen sensor heater control signal	Approx. 0.3V	Approx. 0.3V (At approx. 2,800 rpm and above: Battery voltage)

NOTE: Above voltages are measured values obtained by analogue circuit tester.

GI

EC

AT

BR

ST

RS

HA

EL

SD

# AUTOMATIC TRANSMISSION

## SECTION **AT**

GI

EC

**AT**

BR

ST

RS

HA

EL

SD

## CONTENTS

<b>SHIFT LOCK SYSTEM</b> .....2	Circuit Diagram .....8
Component Parts Location.....2	Control Unit Input/Output Signal Specifications .....10
Shift Lock Circuit Diagram.....2	Shift Pattern .....13
Reverse Buzzer Circuit Diagram .....2	Shift Schedule.....15
<b>TROUBLE DIAGNOSES</b> .....3	Basic Inspection.....16
System Description.....3	Line Pressure Test.....16
Fail-Safe Function.....3	Stall Test .....17
Shift Mechanism .....5	<b>CONSULT</b> .....19
Clutch and Band Chart.....6	Self-diagnosis .....23
Component Parts Location.....7	Symptom Chart.....25

# SHIFT LOCK SYSTEM

## Component Parts Location

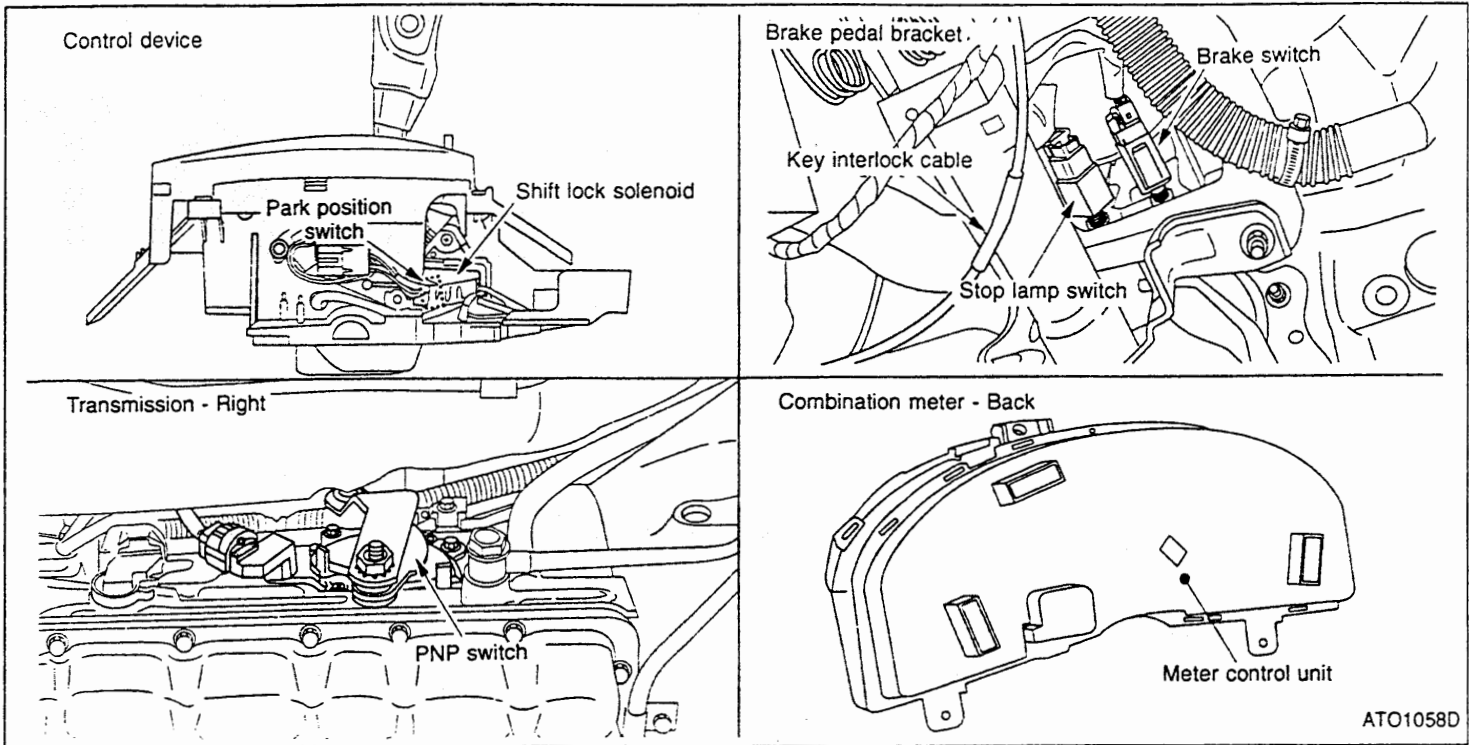

## Shift Lock Circuit Diagram

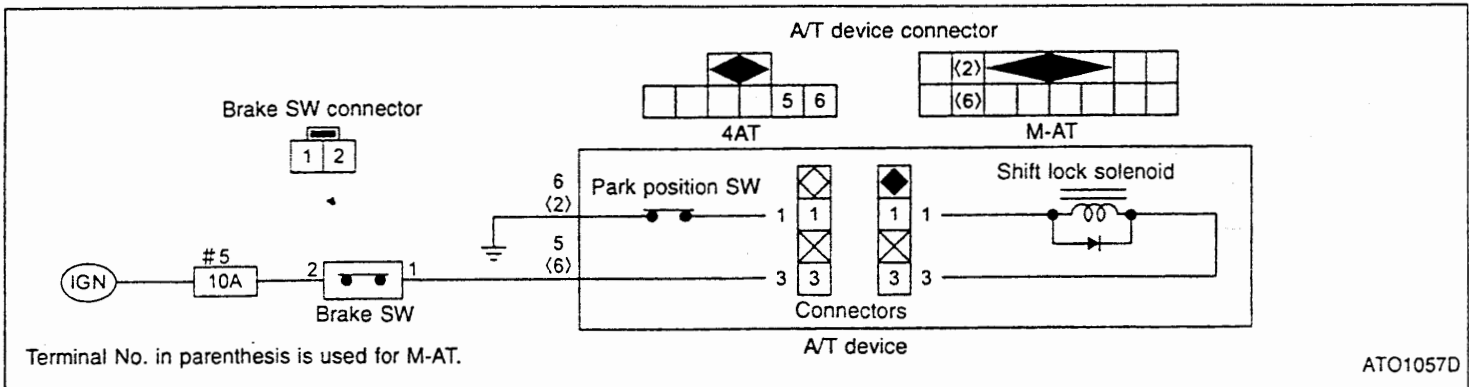

## Reverse Buzzer Circuit Diagram

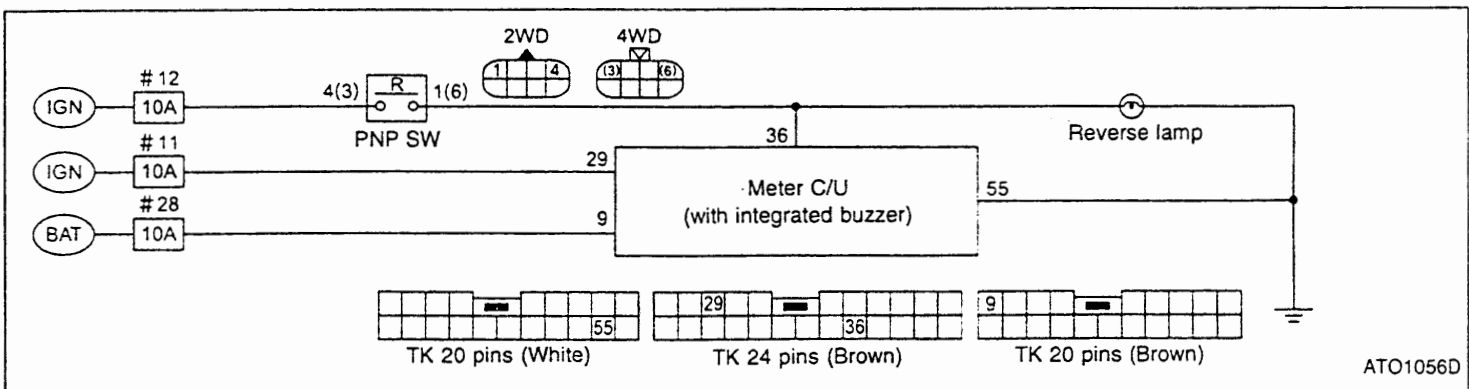

# TROUBLE DIAGNOSES

## System Description

Vehicle with RB20DE and RB25DET engine has TCM integrated into ECM. Vehicle with RB25DE engine has TCM and ECM separately.

## Fail-Safe Function

When malfunction occurs in each sensor and solenoid, the fail-safe functions below enable vehicle to be driven.

### VEHICLE SPEED SENSOR 1 (Output shaft speed sensor)

Inputs a signal from vehicle speed sensor in speedometer.

### THROTTLE POSITION SENSOR

Detects throttle opening by idle switch and full switch, and controls line pressure as follows.

Idle switch	Full switch	Line pressure	Throttle opening
—	ON	Maximum oil pressure	4/8
OFF	OFF		2/8
ON	OFF	Minimum oil pressure	0/8

### PNP SWITCH

When the multiple PNP switch signals are input to TCM and ECM, TCM, the priority of selector lever position becomes as follows by internal TCM determination.

4AT: D, N, R, 2, 1

M-AT: D, N, R, 3, 2

Because the hydraulic circuit of the control valve is switched by manual valve according to the selector lever position, however, actual operating condition of vehicle becomes as follows.

	Actual lever position	PNP switch input signal	Running status	
4AT	P	"P" and other position signals	P	
	R	"R" and other position signals	R	
	N	"N" and other position signals	N	
	D	"D" and other position signals	$D_1 \leftrightarrow D_2 \leftrightarrow D_3$	
	2		"2" and other position signals	$2_1 \leftrightarrow 2_2$
			"2" and "1" position signals	$2_1 \leftrightarrow 2_2$
1	"1" and other position signals	$1_1 \leftrightarrow 1_2$		
M-AT	P	"P" and other position signals	P	
	R	"R" and other position signals	R	
	N	"N" and other position signals	N	
	D	"D" and other position signals	$D_1 \leftrightarrow D_2 \leftrightarrow D_3$	
	3		"3" and other position signals	$3_1 \leftrightarrow 3_2 \leftrightarrow 3_3$
			"3" and "2" position signals	$3_1 \leftrightarrow 3_2 \leftrightarrow 3_3$
2	"2" and other position signals	$2_1 \leftrightarrow 2_2$		

## TROUBLE DIAGNOSES

### Fail-Safe Function (Cont'd)

#### SHIFT SOLENOID A, B

When a malfunctioning signal of solenoid is input to TCM and ECM·TCM, the gear is shifted as follows.

Shift positions	Normal			Abnormal solenoid A			Abnormal solenoid B			Abnormal solenoid A/B				
	A	B	Gears	A	B	Gears	A	B	Gears	A	B	Gears		
"D" position	○	○	1st	—	○→X	3rd	○→X	—	3rd	—	—	3rd		
	X	○	2nd	—	○→X		X	—		—	—			
	X	X	3rd	—	X		X	—		—	—			
	○	X	4th	—	X		○→X	—		—	—			
"3" position (M-AT)	○	○	1st	—	○→X		○→X	—		—	—		—	—
	X	○	2nd	—	○→X		X	—		—	—		—	
	X	X	3rd	—	X		X	—		—	—		—	
"2" position	○	○	1st	—	○→X		○→X	—		—	—		—	—
	X	○	2nd	—	○→X		X	—		—	—		—	
"1" position (4AT)	○	○	1st	—	○→X		○→X	—		—	—		—	—
	X	○	2nd	—	○→X		X	—		—	—		—	

○: Solenoid ON    X: Solenoid OFF    —: Abnormal

#### LINE PRESSURE SOLENOID

When a malfunctioning signal of solenoid is input to TCM and ECM·TCM, the line pressure solenoid is turned OFF, and the line pressure is set to maximum oil pressure.

#### LOCK-UP SOLENOID

When a malfunctioning signal of solenoid is input to TCM and ECM·TCM, the lock-up solenoid is turned OFF, and the lock-up is released.

#### OVERRUN CLUTCH SOLENOID

When a malfunctioning signal of solenoid is input to TCM and ECM·TCM, the overrun clutch solenoid is turned OFF, and the overrun clutch is engaged to apply the engine brake during deceleration.

#### MANUAL MODE SWITCH (M-AT)

When a malfunctioning signal of manual mode switch is input to TCM and ECM·TCM, the gear is controlled with normal "D" position.

#### SHIFT CONTROL UNIT (Except RB20DE)

When a malfunction occurs in the shift control unit, the shift solenoid A/B are turned OFF, and the gear position is controlled with 3rd speed.

#### TURBINE SENSOR (Except RB20DE)

Controlled by vehicle speed sensor 1 in the same way without turbine sensor



Shift Mechanism

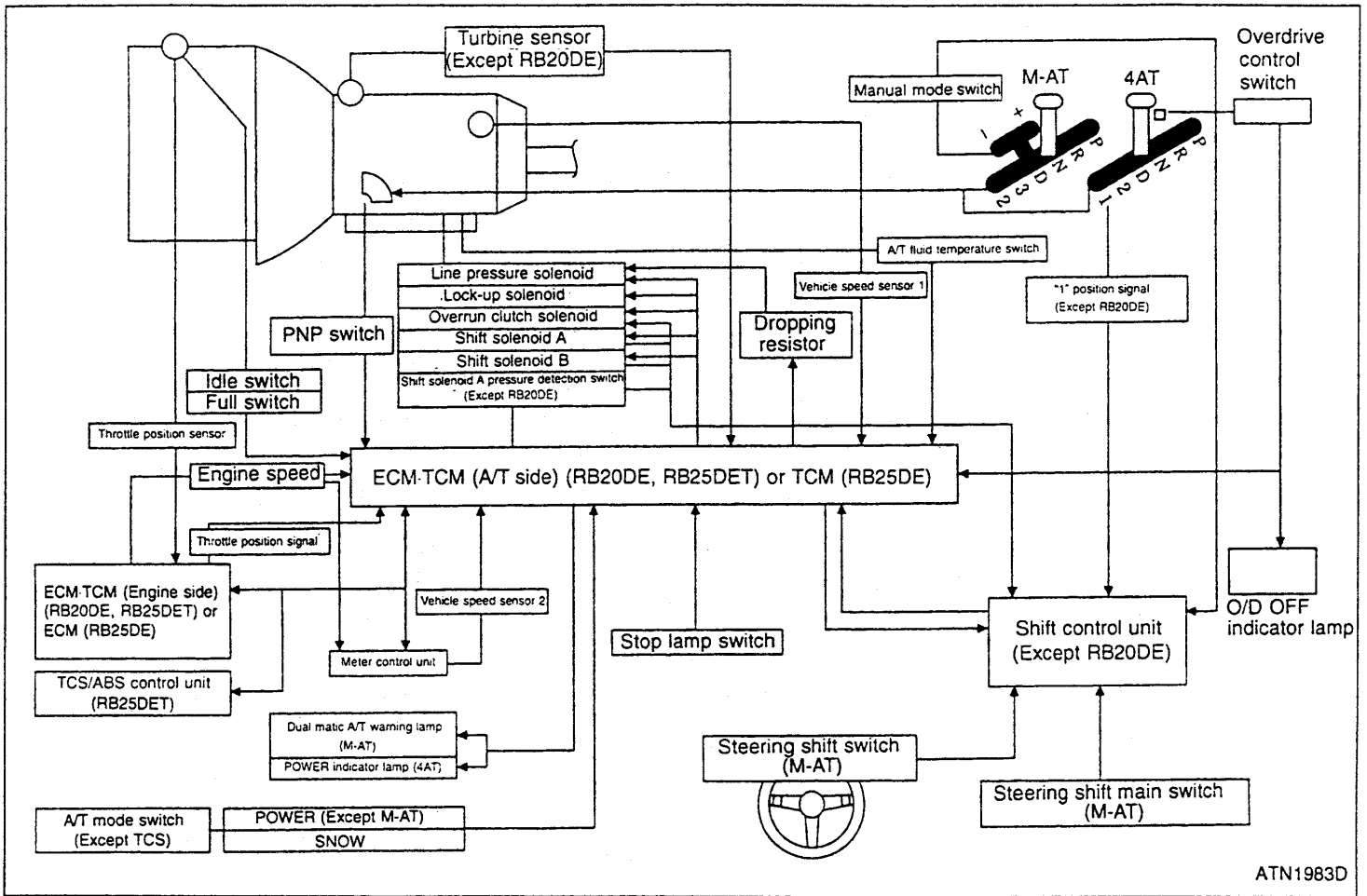

GI  
EC  
**AT**  
BR  
ST  
RS  
HA  
EL  
SD

ATN1983D

# TROUBLE DIAGNOSES

## Clutch and Band Chart

### E-ATx

	R/C (Reverse clutch)	H/C (High clutch)	F/C (For- ward clutch)	O/C (Overrun clutch)	Band servo			F/O-C (Forward one-way clutch)	L/O-C (Low one- way clutch)	L&R/B (Low and reverse brake)	Remarks
					2nd apply	3rd release	4th apply				
P											PARK POSI- TION
R	○									○	REVERSE POSITION
N											NEUTRAL POSITION
*4 D	1st		○	*1⊗				●	●		Automatic shift
	2nd		○	*1⊙	○			●			
	3rd		○	○	*1⊙	*2⊗	⊗		●		
	4th		○	⊗		*3⊗	⊗	○			
2	1st		○	⊗				●	●		Automatic shift
	2nd		○	⊙	○			●			
1	1st		○	○				●		○	Locked in 1st
	2nd		○	○	○			●			

### DUAL MATIC M-ATx

	R/C (Reverse clutch)	H/C (High clutch)	F/C (For- ward clutch)	O/C (Overrun clutch)	Band servo			F/O-C (Forward one-way clutch)	L/O-C (Low one- way clutch)	L&R/B (Low and reverse brake)	Remarks
					2nd apply	3rd release	4th apply				
P											PARK POSI- TION
R	○									○	REVERSE POSITION
N											NEUTRAL POSITION
D	1st		○	⊗				●	●		Automatic shift
	2nd		○	⊙	○			●			
	3rd		○	○	⊙	*2⊗	⊗		●		
	4th		○	⊗		*3⊗	⊗	○			
3	1st		○	⊗				●	●		Automatic shift
	2nd		○	⊙	○			●			
	3rd		○	○	⊙	*2⊗	⊗		●		
2	1st		○	⊗				●		○	Automatic shift
	2nd		○	⊙	○			●			

\*1: Operate when overdrive control switch is being set in "OFF" position. (D<sub>4</sub> shift is inhibited.)

\*2: Oil pressure is applied to both 2nd "apply" side and 3rd "release" side of band servo piston. However, brake band does not contract because oil pressure area on the "release" side is greater than that on the "apply" side.

\*3: Oil pressure is applied to 4th "apply" side in condition \*2 above, and brake band contracts.

\*4: AT will not shift to 4th when overdrive control switch is set in "OFF" position.

○: Operates.

●: Operates during "progressive" acceleration.

⊗: Operates but does not affect power transmission.

⊙: Operates when throttle opening is less than specification, but does not affect engine brake.

⊙: Operates when throttle opening is less than specification, activating engine brake.

# TROUBLE DIAGNOSES

## Component Parts Location

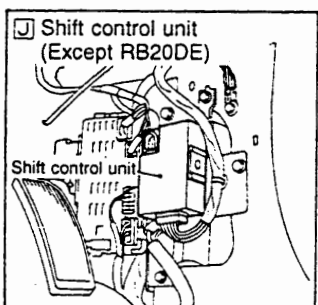
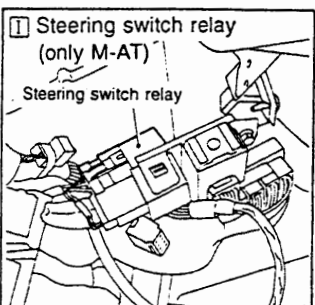
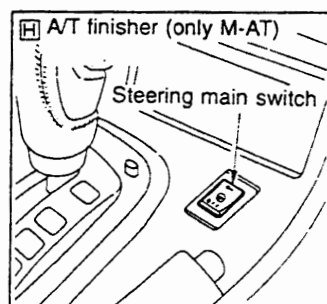
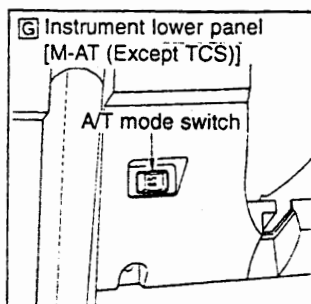
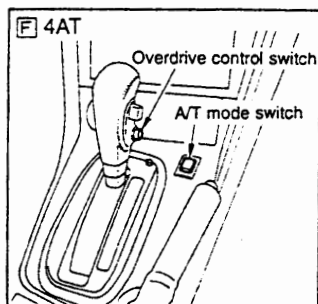
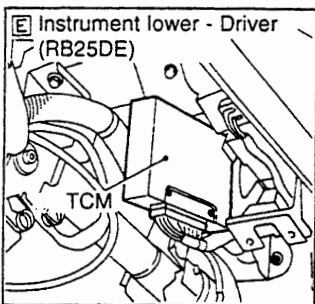
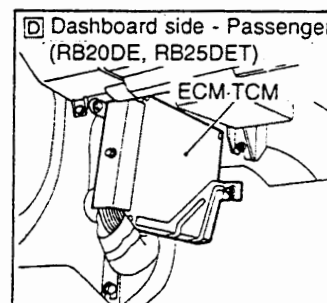
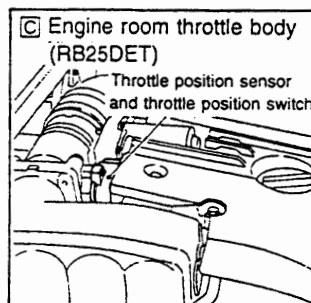
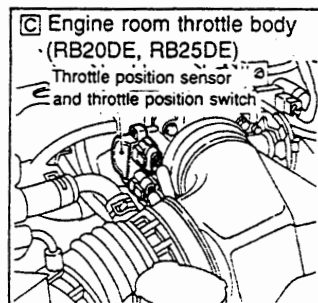
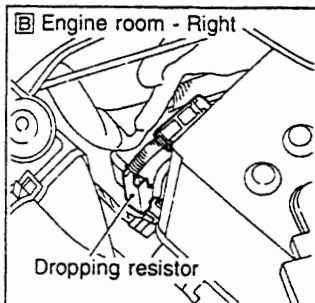
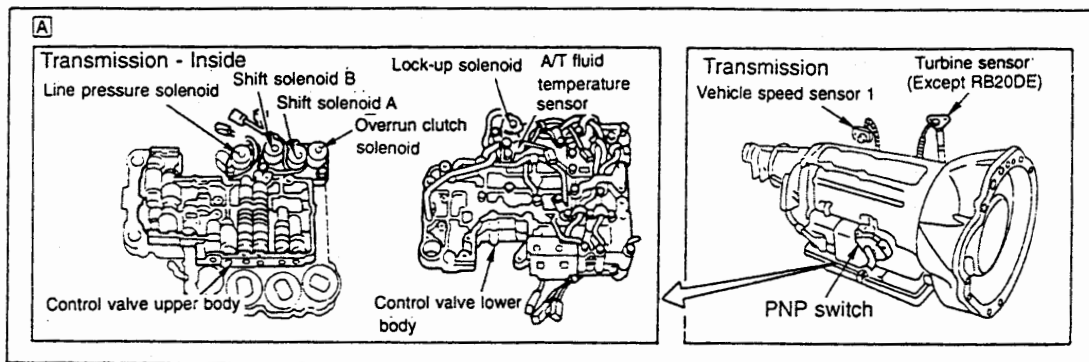
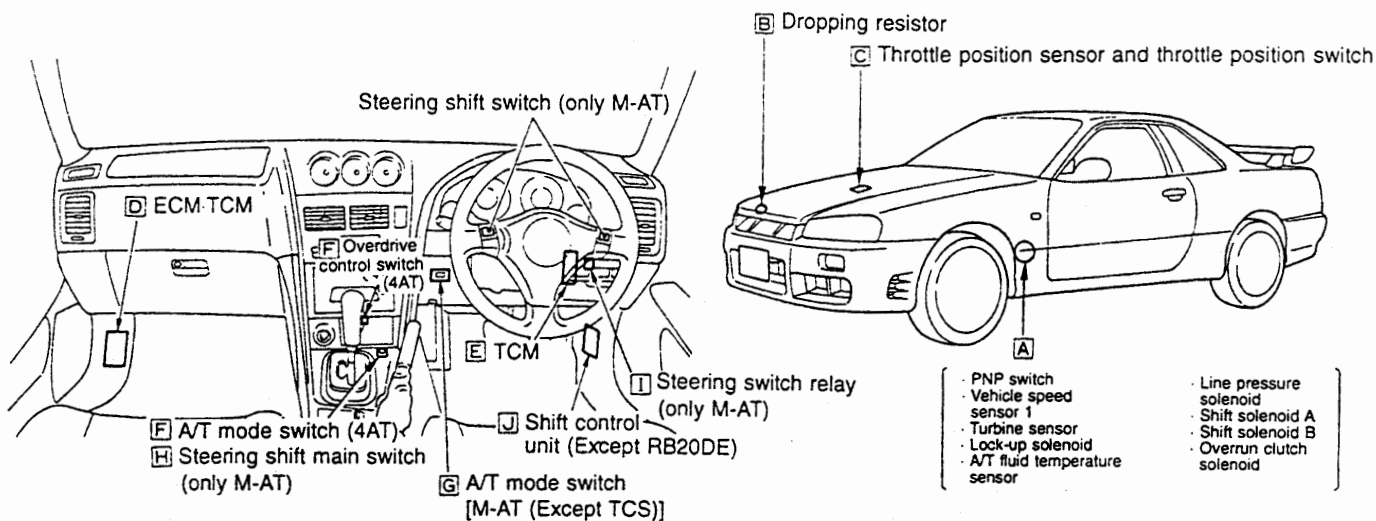

G1  
EC  
AT  
BR  
ST  
RS  
HA  
EL  
SD

## Circuit Diagram

RB20DE, RB25DET

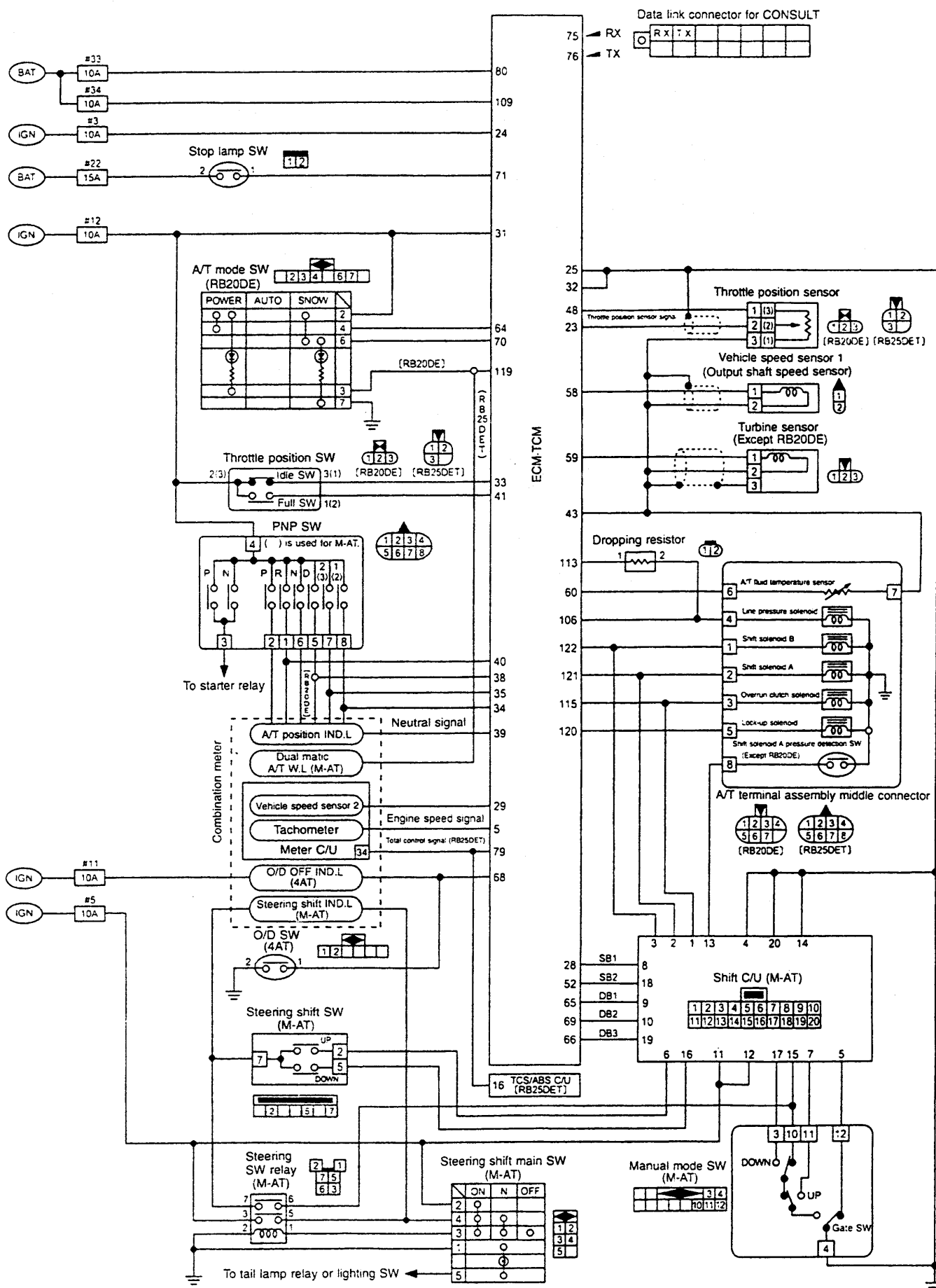

Terminal No. in parenthesis ( ) of throttle position sensor and throttle position switch is used for RB25DET.

# TROUBLE DIAGNOSES

## Circuit Diagram (Cont'd)

RB25DE

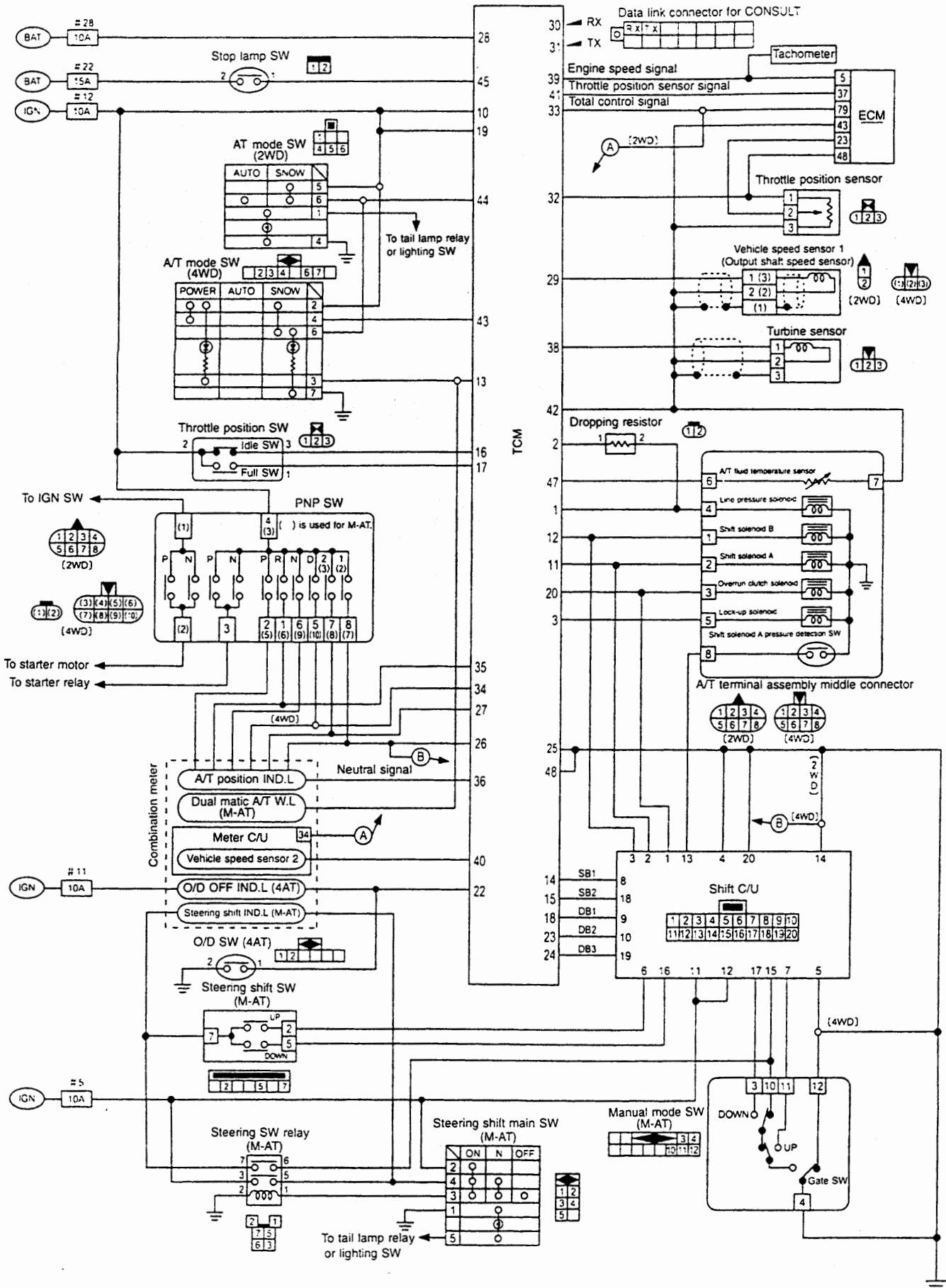

GI  
 EC  
**AT**  
 BR  
 ST  
 RS  
 HA  
 EL  
 SD

ATN1987D

# TROUBLE DIAGNOSES

## Control Unit Input/Output Signal Specifications

Refer to EC section ("ECM-TCM or ECM Input/Output Signal Reference Value").

### USING CONSULT

Monitor item	Indication value	Operating status
Throttle position sensor	Approx. 0.4 - 4.0V	Throttle fully - closed to fully-open
A/T fluid temperature sensor	Approx. 1.5 - 0.5V	A/T fluid: Approx. 20 - 80°C
Lever switch	ON	Overdrive control switch: OFF
	OFF	Overdrive control switch: ON
Line pressure duty	29 - 94%	Low pressure - High pressure
Lock-up duty	4 - 94%	Lock-up released - Lock-up engaged

### USING CIRCUIT TESTER

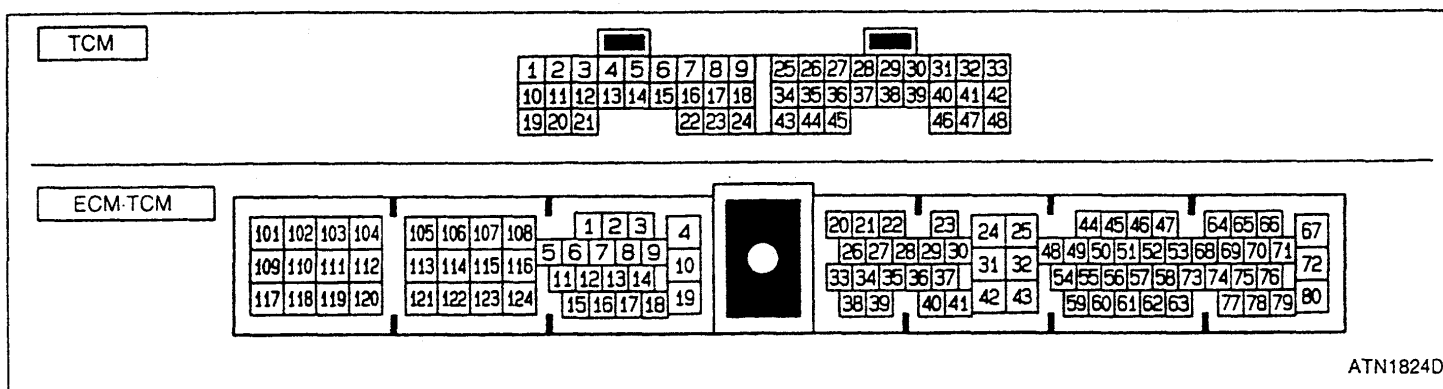

ATN1824D

Terminal No.*	Item	Condition	Specifications
5 (39)	Engine speed signal	—	Refer to EC section ("ECM-TCM or ECM Input/Output Signal Reference Value").
23 (41)	Throttle position sensor signal	After engine warm-up, depress accelerator pedal slowly.	Voltage increases gradually in response to throttle position. Fully-closed throttle : Approx. 0.5V Fully-open throttle : Approx. 4.2V
24 (10) 31 (19)	Power source	Turn ignition switch ON.	Battery voltage
		Turn ignition switch OFF.	Approx. 0V
25 (25) 32 (48)	Ground	Turn ignition switch ON.	Approx. 0V
28 (14)	Shift control signal SB1 (Except RB20DE)	—	—
29 (40)	Vehicle speed sensor 2 (vehicle speed signal in speedometer)	When vehicle is moved at 2 to 3 km/h for more than 1 m.	Voltage varies approx. between 0V and 4.5V intermittently.

\*: Each number in parenthesis ( ) shows the terminal No. for TCM (RB25DE).

# TROUBLE DIAGNOSES

## Control Unit Input/Output Signal Specifications (Cont'd)

Terminal No.*	Item	Operation or measurement condition		Specifications	
33 (16)	Idle switch (in throttle position switch)	Ignition switch ON	After engine warm-up, release accelerator pedal.	Battery voltage	
			After engine warm-up, depress accelerator pedal.	Approx. 0V	
34 (26)	PNP switch "1" <"2"> position ( < > is used for M-AT.)		Selector lever: "1" <"2"> position	Battery voltage	
			Selector lever: Except "1" <"2"> position	Approx. 0V	
35 (27)	PNP switch "2" <"3"> position ( < > is used for M-AT.)		Selector lever: "2" <"3"> position	Battery voltage	
			Selector lever: Except "2" <"3"> position	Approx. 0V	
38 (34)	PNP switch "D" position		Selector lever: "D" position	Battery voltage	
			Selector lever: Except "D" position	Approx. 0V	
39 (36)	Neutral signal (PNP switch "N-P" position)		Selector lever: "N", "P" position	Approx. 0V	
			Selector lever: Except "N", "P" position	Approx. 4.7V	
40 (35)	PNP switch "R" position	Selector lever: "R" position	Battery voltage		
		Selector lever: Except "R" position	Approx. 0V		
41 (17)	Full switch (in throttle position switch)	After engine warm-up, depress accelerator pedal partially. (Throttle opening: More than 50%)	Battery voltage		
		After engine warm-up, release accelerator pedal.	Approx. 0V		
43 (42)	Sensor ground	Turn ignition switch ON.	Approx. 0V		
48 (32)	Throttle position sensor power	Turn ignition switch ON.	Approx. 4.5 - 5.5V		
		Turn ignition switch OFF.	Approx. 0V		
52 (15)	Shift control signal SB2 (Except RB20DE)	—	—		
58 (29)	Vehicle speed sensor 1 (Output shaft speed sensor)	When vehicle cruises at 30 km/h (Inspected in AC position)	More than approx. 1V (Voltage increases in response to vehicle speed.)		
		When vehicle parks (Inspected in AC position)	Approx. 0V		
59 (38)	Turbine sensor (Except RB20DE)	When turbine rotates at approx. 1,000 rpm	Approx. 0.1V		
60 (47)	A/T fluid temperature sensor	Ignition switch ON	A/T fluid temperature: Approx. 20°C	Approx. 1.5V	
			A/T fluid temperature: Approx. 80°C	Approx. 0.5V	
64 (43)	A/T mode switch (POWER) (Except M-AT)		A/T mode switch: POWER	Battery voltage	
			A/T mode switch: Except POWER	Approx. 0V	
65 (18)	Shift control signal DB1 (Except RB20DE)		—	—	
66 (24)	Shift control signal DB3 (Except RB20DE)		—	—	
68 (22)	Overdrive control switch (Except M-AT)		Ignition switch ON	Overdrive control switch: ON (Contact: OFF)	Battery voltage
				Overdrive control switch: OFF (Contact: ON)	Approx. 0V
69 (23)	Shift control signal DB2 (Except RB20DE)		—	—	
70 (44)	A/T mode switch (SNOW) (Except TCS)		Ignition switch ON	A/T mode switch: SNOW	Battery voltage
		A/T mode switch: Except SNOW		Approx. 0V	
71 (45)	Stop lamp switch	Depress brake pedal.		Battery voltage	
		Release brake pedal.		Approx. 0V	
75 (30)	CONSULT (RX) signal	—		—	
76 (31)	CONSULT (TX) signal	—		—	

\*: Each number in parenthesis ( ) shows the terminal No. for TCM (RB25DE).

## TROUBLE DIAGNOSES

### Control Unit Input/Output Signal Specifications (Cont'd)

Terminal No.*	Item	Operation or measurement condition		Specifications
79 (33)	Total control signal (multiple communication) (Except RB20DE)	—		Refer to EC section ("ECM-TCM or ECM Input/Output Signal Reference Value").
80 (28)	Power supply (Backup)	Turn ignition switch ON.		Battery voltage
109 (28)		Turn ignition switch OFF.		Battery voltage
106 (1)	Line pressure solenoid	Ignition switch ON	After engine warm-up, release accelerator pedal.	Approx. 1.5 - 3.0V
			After engine warm-up, depress accelerator pedal fully.	Approx. 0V
113 (2)	Line pressure solenoid (dropping resistor circuit)	Ignition switch ON	After engine warm-up, release accelerator pedal.	Approx. 4 - 14V
			After engine warm-up, depress accelerator pedal fully.	Approx. 0V
115 (20)	Overrun clutch solenoid	Driving	When overrun clutch solenoid operates	Battery voltage
			When overrun clutch solenoid does not operate	Approx. 0V
119 (13)	POWER indicator lamp (4AT) Dual matic A/T warning lamp (M-AT)	Ignition switch ON	When POWER indicator lamp is turned on (A/T mode switch: POWER), or dual matic A/T warning lamp is turned on	Approx. 0V
			When POWER indicator lamp is turned off (A/T mode switch: Except POWER), or dual matic A/T warning lamp is turned off	Battery voltage
120 (3)	Lock-up solenoid		When vehicle is locked up	Approx. 8 - 15V
			When vehicle is not locked up	Approx. 0V
121 (11)	Shift solenoid A	Driving	When shift solenoid A operates (Driving in "D <sub>1</sub> " or "D <sub>4</sub> ")	Battery voltage
			When shift solenoid A does not operate (Driving in "D <sub>2</sub> " or "D <sub>3</sub> ")	Approx. 0V
122 (12)	Shift solenoid B	Driving	When shift solenoid B operates (Driving in "D <sub>1</sub> " or "D <sub>2</sub> ")	Battery voltage
			When shift solenoid B does not operate (Driving in "D <sub>3</sub> " or "D <sub>4</sub> ")	Approx. 0V

\*: Each number in parenthesis ( ) shows the terminal No. for TCM (RB25DE ).



# TROUBLE DIAGNOSES

## Shift Pattern

RB20DE ENGINE (4AX03 model)

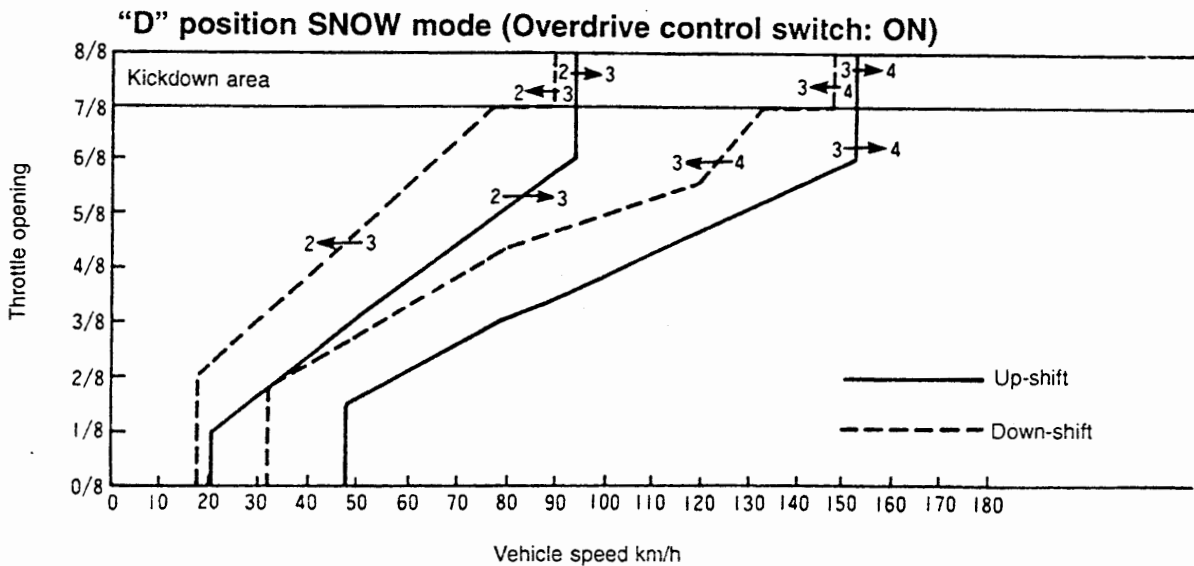
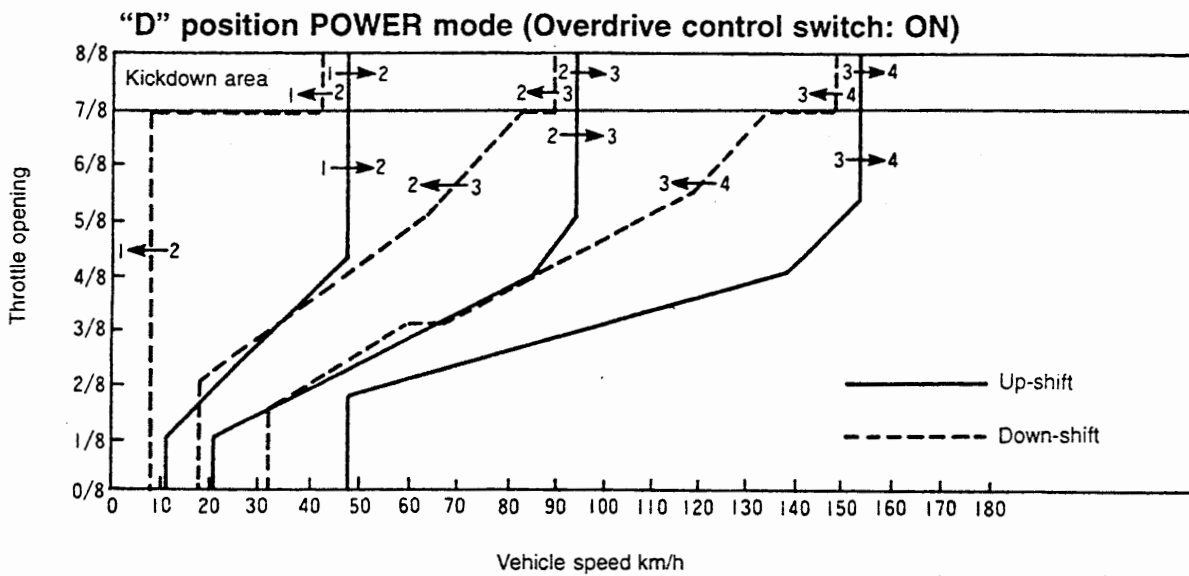
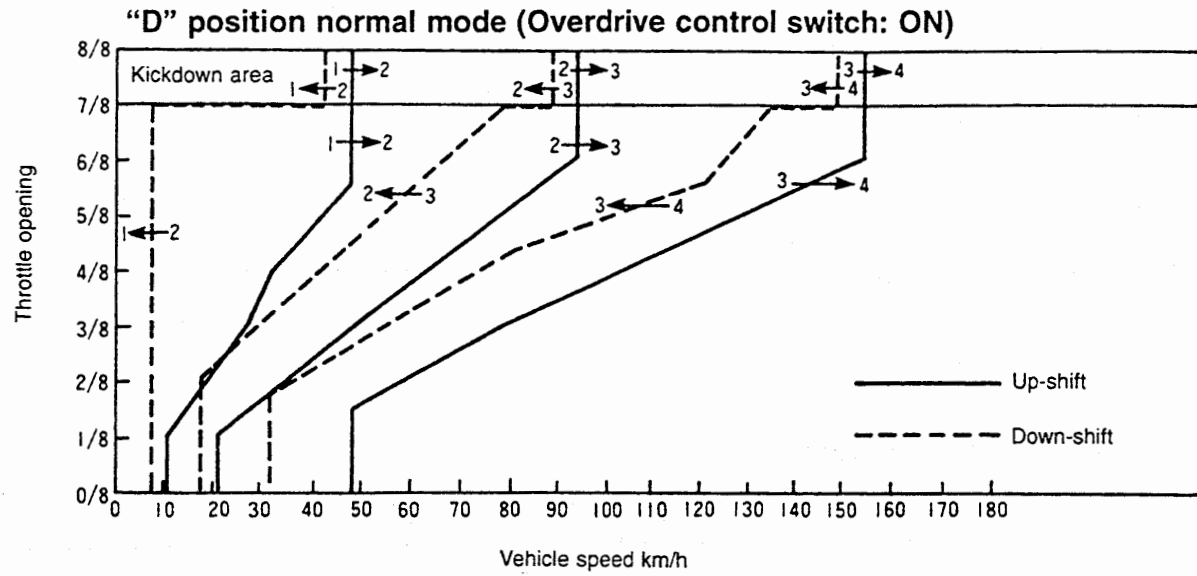

GI

EC

AT

BR

ST

RS

HA

EL

SD

# TROUBLE DIAGNOSES

## Shift Pattern (Cont'd)

### RB25DE ENGINE (4AX01 model)

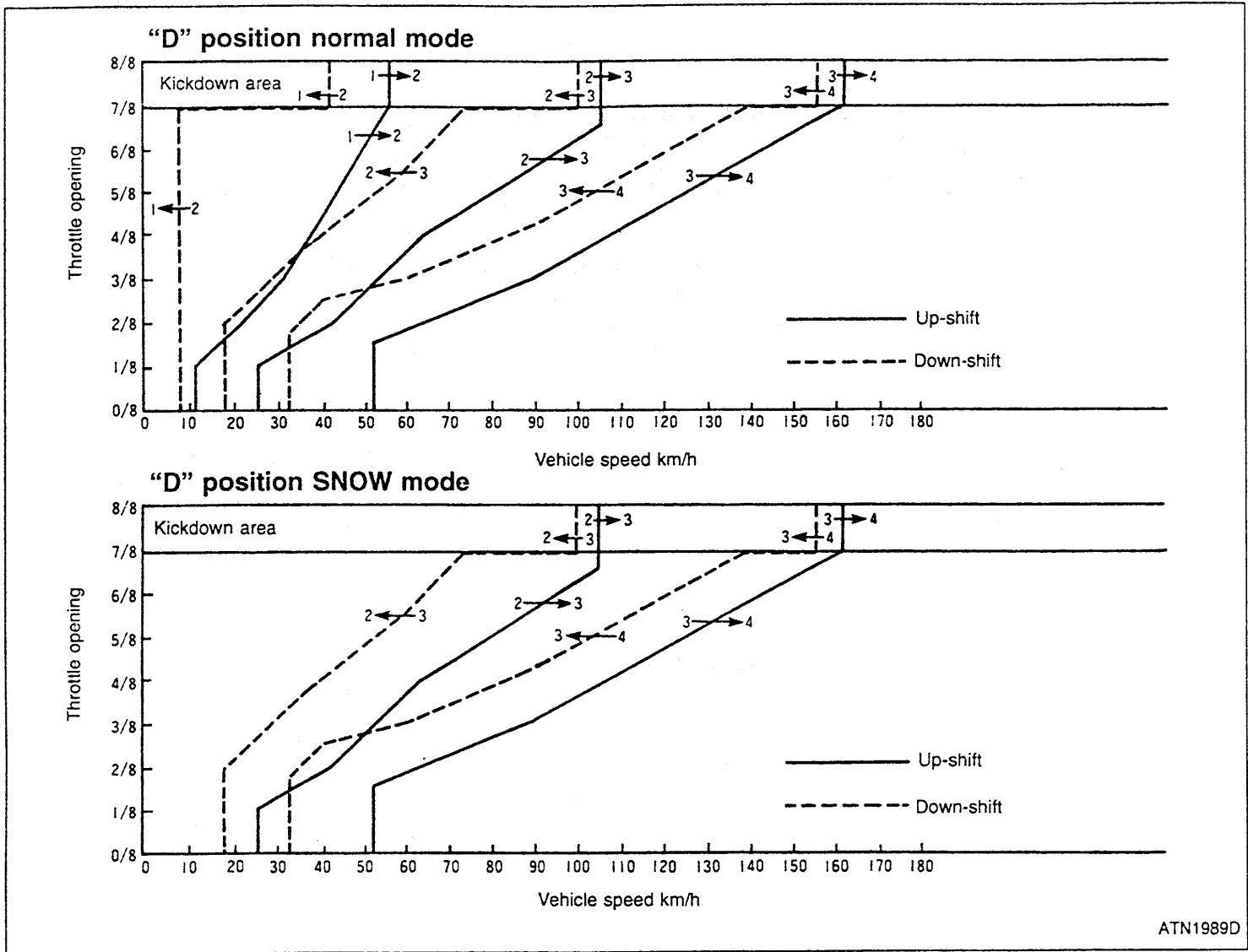

ATN1989D

### RB25DET ENGINE (4AX00 model)

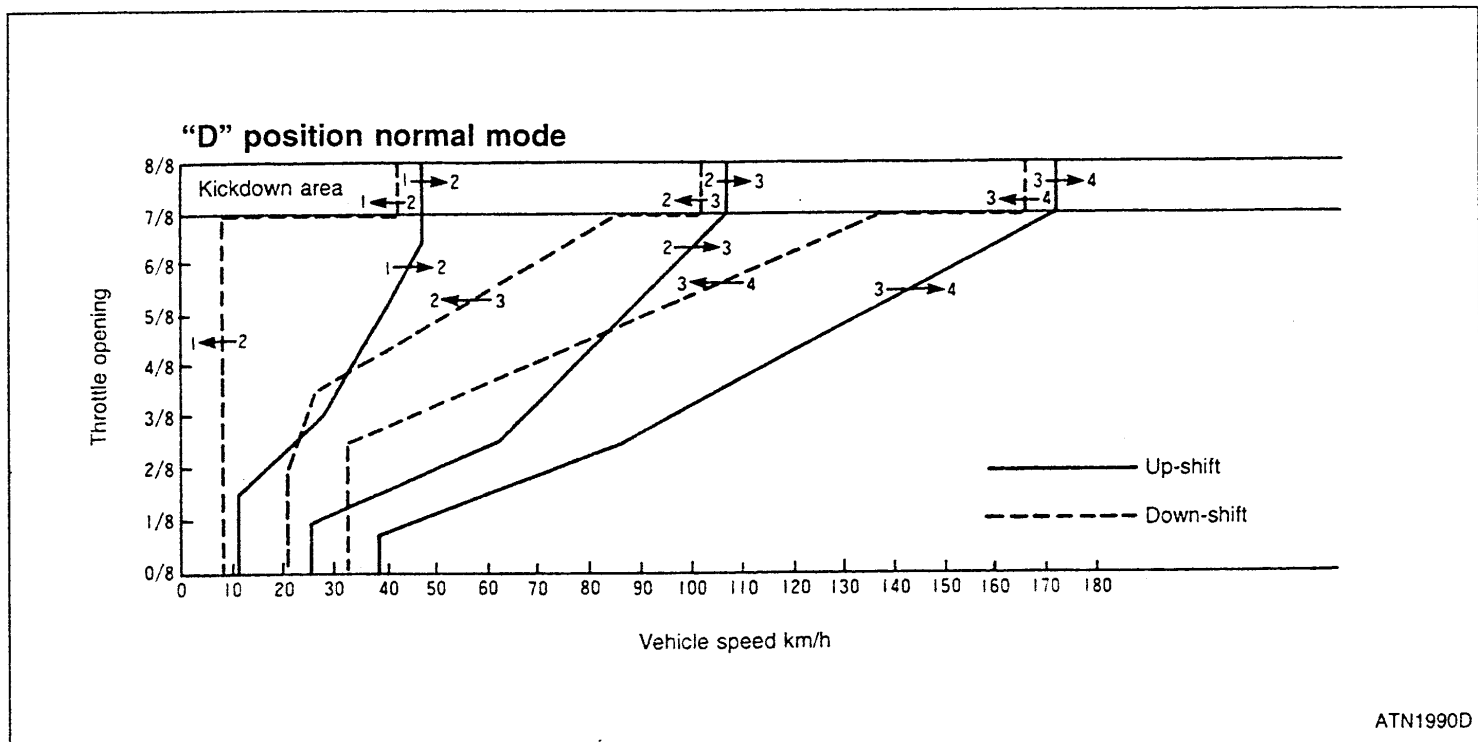

ATN1990D

# TROUBLE DIAGNOSES

## Shift Schedule

### VEHICLE SPEED WHEN SHIFTING GEARS

#### RB20DE engine (4AX03 model)

Throttle opening	Shift pattern	Vehicle speed km/h					
		D <sub>1</sub> →D <sub>2</sub>	D <sub>2</sub> →D <sub>3</sub>	D <sub>3</sub> →D <sub>4</sub>	D <sub>4</sub> →D <sub>3</sub>	D <sub>3</sub> →D <sub>2</sub>	D <sub>2</sub> →D <sub>1</sub>
Full throttle	Normal	46 - 50	91 - 99	149 - 159	144 - 154	86 - 94	41 - 45
	Power	46 - 50	91 - 99	149 - 159	144 - 154	86 - 94	41 - 45
Half throttle	Normal	31 - 35	62 - 68	101 - 109	71 - 79	41 - 45	6 - 10
	Power	43 - 47	84 - 90	135 - 143	83 - 91	45 - 51	6 - 10

#### RB25DE engine (4AX01 model)

Throttle opening	Shift pattern	Vehicle speed km/h					
		D <sub>1</sub> →D <sub>2</sub>	D <sub>2</sub> →D <sub>3</sub>	D <sub>3</sub> →D <sub>4</sub>	D <sub>4</sub> →D <sub>3</sub>	D <sub>3</sub> →D <sub>2</sub>	D <sub>2</sub> →D <sub>1</sub>
Full throttle	Normal	50 - 54	101 - 109	157 - 167	151 - 161	96 - 104	40 - 44
	Power	50 - 54	101 - 109	157 - 167	151 - 161	96 - 104	40 - 44
Half throttle	Normal	32 - 36	61 - 67	104 - 112	80 - 88	37 - 43	6 - 10
	Power	42 - 46	85 - 91	135 - 143	87 - 95	45 - 51	6 - 10

#### RB25DET engine (4AX00 model)

Throttle opening	Shift pattern	Vehicle speed km/h					
		D <sub>1</sub> →D <sub>2</sub>	D <sub>2</sub> →D <sub>3</sub>	D <sub>3</sub> →D <sub>4</sub>	D <sub>4</sub> →D <sub>3</sub>	D <sub>3</sub> →D <sub>2</sub>	D <sub>2</sub> →D <sub>1</sub>
Full throttle	Normal	45 - 49	103 - 111	167 - 177	161 - 171	98 - 106	40 - 44
	Power	45 - 49	103 - 111	167 - 177	161 - 171	98 - 106	40 - 44
Half throttle	Normal	31 - 35	74 - 80	111 - 119	63 - 71	32 - 38	6 - 10
	Power	39 - 43	84 - 90	133 - 141	98 - 106	50 - 56	6 - 10

### VEHICLE SPEED WHEN PERFORMING LOCK-UP

Engine type		RB20DE	RB25DE	RB25DET	
Model No.		4AX03	4AX01	4AX00	
D <sub>3</sub> speed	Lock-up ON km/h	Closed throttle	31 - 39	34 - 42	—
		Half throttle	—	—	—
D <sub>3</sub> speed	Lock-up OFF km/h	Closed throttle	23 - 31	25 - 33	59 - 67
		Half throttle	101 - 109	104 - 112	121 - 129
D <sub>4</sub> speed	Lock-up ON km/h	Closed throttle	44 - 52	48 - 56	55 - 63
		Half throttle	120 - 128	118 - 126	128 - 136
D <sub>4</sub> speed	Lock-up OFF km/h	Closed throttle	35 - 43	38 - 46	52 - 60
		Half throttle	110 - 118	107 - 115	103 - 111

Closed throttle: Throttle opening is 1/8 or below, and idle switch is turned OFF.

Half throttle: Throttle opening is 4/8.

GI  
 EC  
 AT  
 BR  
 ST  
 RS  
 HA  
 EL  
 SD

# TROUBLE DIAGNOSES

## Basic Inspection

### A/T FLUID

- Check A/T fluid for leakage and fluid level.
- Check A/T fluid status.

### SHIFT CONTROL

Check and adjust A/T position.

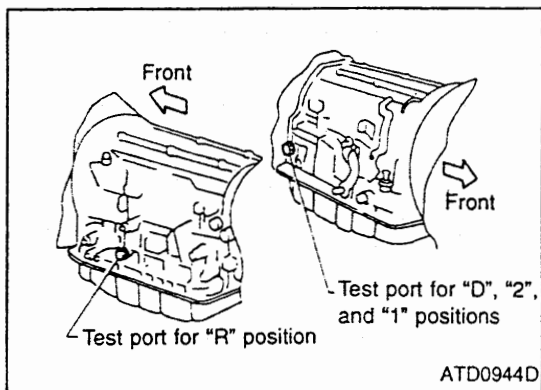

## Line Pressure Test

1. Check engine oil level. If necessary, add oil.
2. Drive vehicle for approximately 10 minutes until A/T fluid reaches normal operating temperature between 50 and 80°C, and check A/T fluid level. If necessary, add A/T fluid.
  - When ambient temperature is 20°C, A/T fluid operating temperature usually becomes between 50 and 80°C for approximately 10 minutes' drive in urban traffic.
3. After warming up A/T, remove fluid pressure detection plug, and install pressure gauge (Special Service Tool: ST2505 S001) to corresponding line pressure port.

### CAUTION:

- To remove or install the fluid pressure detection plug, use standard socket wrench (width across flat: 12 mm).
  - Detection plug should not be reused because thread-lock compound is applied to the plug.
4. Set parking brake and block wheels.
  5. Start engine and measure line pressure at idle and stall speed.

### CAUTION:

- When measuring line pressure, depress brake pedal fully.
- When measuring line pressure at stall speed, refer to "Stall Test" (AT-17).

## Line pressure specification

Engine speed	Line pressure MPa (kg/cm <sup>2</sup> )	
	"R" position	"D", "2", "1" positions (4AT) "D", "3", "2" positions (M-AT)
At idle speed	0.58 - 0.62 (5.9 - 6.3)	0.47 - 0.51 (4.8 - 5.2)
At stall speed	1.71 - 1.78 (17.4 - 18.2)	1.22 - 1.29 (12.4 - 13.2)

# TROUBLE DIAGNOSES

## Line Pressure Test (Cont'd)

### JUDGEMENT OF LINE PRESSURE TEST

	Judgement	Possible causes
At idle speed	Line pressure is low in all positions.	Pressure supply system malfunction or low oil pump output Examples: <ul style="list-style-type: none"> <li>● Oil pump wear</li> <li>● Control piston damage</li> <li>● Pressure regulator valve or plug sticking, and weak spring</li> <li>● Fluid pressure leakage between oil strainer and pressure regulator valve through oil pump</li> <li>● Low idle speed</li> </ul>
	Line pressure is low in particular position.	After line pressure is supplied from manual valve, fluid pressure may leak between devices or circuits of corresponding position.
	Line pressure is high.	Malfunctions of sensors or pressure regulation function. Examples: <ul style="list-style-type: none"> <li>● Misadjustment of throttle position sensor</li> <li>● A/T fluid temperature sensor damaged</li> <li>● Poor operation of line pressure solenoid (stuck with OFF status, clogged filter, or open harness)</li> <li>● Pressure modifier valve sticking</li> <li>● Pressure regulator valve or plug sticking</li> </ul>
At stall speed	Line pressure increase is poorer than that measured at idle speed.	Malfunctions of sensors or pressure regulation function Examples: <ul style="list-style-type: none"> <li>● Misadjustment of throttle position sensor</li> <li>● TCM, ECM-TCM damaged</li> <li>● Poor operation of line pressure solenoid (stuck or shorted with ON status)</li> <li>● Pressure regulator valve and plug sticking</li> <li>● Pressure modifier valve sticking</li> <li>● Pilot valve sticking and pilot filter clogged</li> </ul>
	Line pressure increases but does not reach specification.	Malfunctions of pressure supply system, sensors, or pressure regulation function Examples: <ul style="list-style-type: none"> <li>● Misadjustment of throttle position sensor</li> <li>● Control piston damage</li> <li>● Poor operation of line pressure solenoid, and filter sticking or clogged</li> <li>● Pressure regulator valve and plug sticking</li> <li>● Pressure modifier valve sticking</li> <li>● Pilot valve sticking and pilot filter clogged</li> </ul>
	Line pressure is low in particular position.	After line pressure is supplied from manual valve, fluid pressure may leak between devices or circuits of corresponding position.

GI  
 EC  
**AT**  
 BR  
 ST  
 RS  
 HA  
 EL  
 SD

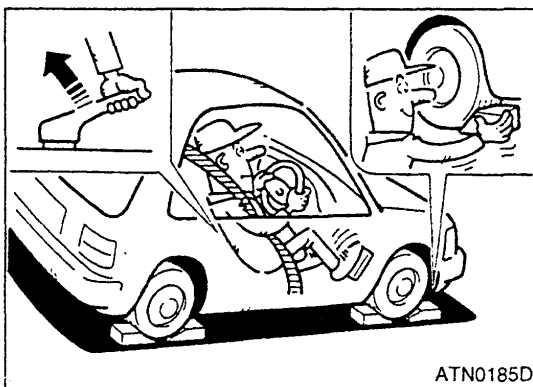

### Stall Test

1. Check engine oil level. If necessary, add oil.
2. Drive vehicle for approximately 10 minutes until A/T fluid reaches normal operating temperature between 50 and 80°C, and check A/T fluid level. If necessary, add A/T fluid.
  - When ambient temperature is 20°C, A/T fluid operating temperature usually becomes between 50 and 80°C for approximately 10 minutes' drive in urban traffic.
3. Set parking brake and block wheels.
4. Start engine, depress brake pedal, and move selector lever to "D" position.

# TROUBLE DIAGNOSES

## Stall Test (Cont'd)

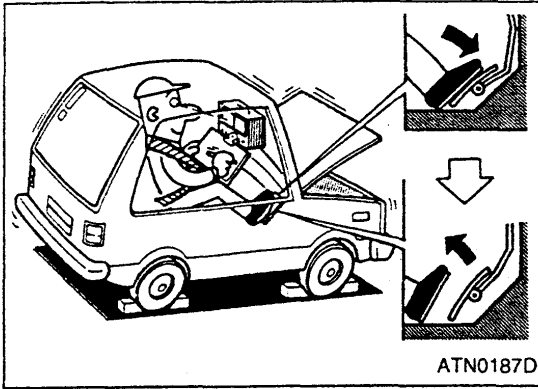

5. Depress accelerator pedal gradually while depressing brake pedal.
6. Read stall speed quickly, and immediately release accelerator pedal.

**CAUTION:**

**Do not depress accelerator pedal for more than 5 seconds when testing.**

7. Move selector lever to "N" position.
8. Cool down A/T fluid.

**CAUTION:**

**Run engine at idle for at least one minute.**

**Specification:**

- RB20DE 2,300 - 2,500 rpm**
- RB25DE 2,350 - 2,550 rpm**
- RB25DET 2,920 - 3,170 rpm**

## JUDGEMENT OF STALL SPEED

	Lever position				Possible causes
	D	2	1	R	
Stall speed status	H	H	H	O	<ul style="list-style-type: none"> <li>● Forward clutch</li> <li>● Forward one-way clutch</li> <li>● Low one-way clutch</li> </ul>
	O	O	O	H	<ul style="list-style-type: none"> <li>● Low &amp; reverse brake</li> <li>● Reverse clutch</li> </ul>
	L	L	L	L	<ul style="list-style-type: none"> <li>● Engine and torque converter one-way clutch</li> </ul>
	H	H	H	H	<ul style="list-style-type: none"> <li>● Line pressure circuit (line pressure drop), forward clutch, low one-way clutch and forward one-way clutch</li> <li>● Line pressure circuit (line pressure drop), reverse clutch and forward clutch</li> <li>● Forward clutch, low one-way clutch, forward one-way clutch, reverse clutch and forward clutch</li> <li>● Line pressure circuit (line pressure drop), forward clutch, low one-way clutch, forward one-way clutch, reverse clutch and forward clutch</li> </ul>
	O	O	O	O	<ul style="list-style-type: none"> <li>● Clutches and brake are normal except high clutch, brake band, and overrun clutch. (However, status of high clutch, brake band, and overrun clutch cannot be confirmed by stall test.)</li> </ul>

- O: Within stall speed specification
- H: Higher than stall speed specification
- L: Lower than stall speed specification

# TROUBLE DIAGNOSES

## CONSULT

### DESCRIPTION

- CONSULT indicates operation timing of each solenoid such as electrical shift timing and lock-up timing. Therefore, when there is a definite difference between shift timing detected from shift shock (or engine speed variation) and the one indicated by CONSULT, mechanical parts other than solenoids and sensors (including hydraulic circuit) may be malfunctioning. In this case, check the mechanical parts using applicable diagnostic procedures.
- Shift schedule (which implies gear position) displayed on CONSULT and that indicated in Service Manual may differ slightly. This occurs because of the following reasons:
  - Actual shift schedule has more or less tolerance or allowance.
  - Shift schedule indicated in Service Manual refers to the point where shifts start, and gear position displayed on CONSULT indicates the point where shifts are completed.
  - Shift solenoid valve A or B (ON/OFF) is displayed on CONSULT at the start of shifting. Gear position is displayed upon completion of shifting (which is computed by TCM).
- To make sure the part No. of ECM-TCM on CONSULT, touch "ENGINE" to verify "C/U PART NUMBER".

GI

EC

AT

BR

ST

RS

HA

EL

SD

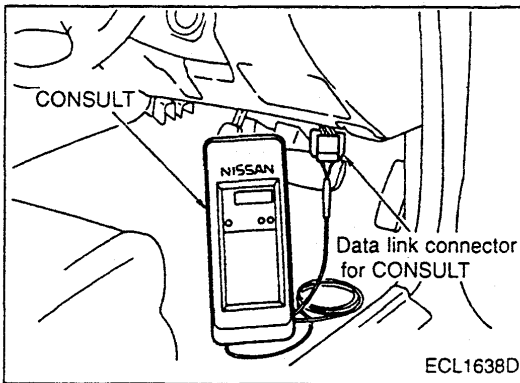

### SELF-DIAGNOSIS PROCEDURE

Refer to "CONSULT Instruction Manual - Supplement" in details.

1. Turn ignition switch OFF.
2. Connect CONSULT connector to data link connector.
3. Start engine.
4. Touch "START", "A/T" and "SELF-DIAG RESULTS" sequentially on CONSULT screen.
5. Self-diagnosis results are displayed on the screen.

# TROUBLE DIAGNOSES

## CONSULT (Cont'd)

### SELF-DIAGNOSTIC RESULTS MODE

Diagnostic item	Diagnostic item is detected when...	Inspection item
VHCL SPEED SEN-A/T	<ul style="list-style-type: none"> <li>TCM does not receive vehicle speed sensor 1 signal due to open circuit, etc.</li> <li>TCM receives improper signal during driving.</li> <li>After ignition switch is turned ON, vehicle speed sensor 2 receives improper signal until vehicle starts to run.</li> </ul>	Vehicle speed sensor 1 circuit
VHCL SPEED SEN-MTR	<ul style="list-style-type: none"> <li>TCM does not receive vehicle speed sensor 2 signal due to open circuit, etc.</li> <li>TCM receives improper signal during driving.</li> </ul>	Vehicle speed sensor 2 circuit
THROTTLE POSI SEN	TCM detects following conditions during driving (Except N and P positions). <ul style="list-style-type: none"> <li>Excessively high throttle position sensor signal voltage</li> <li>Excessively low throttle position sensor signal voltage with idle switch OFF or full switch ON</li> </ul>	Throttle position sensor circuit
SHIFT SOLENOID/V A	<ul style="list-style-type: none"> <li>Specified voltage is not applied to solenoid due to open and/or short circuit.</li> </ul>	Shift solenoid A circuit
SHIFT SOLENOID/V B		Shift solenoid B circuit
OVERRUN CLUTCH S/V		Overrun clutch solenoid circuit
T/C CLUTCH SOL/V		Lock-up solenoid circuit
LINE PRESSURE S/V		Line pressure solenoid circuit
BATT/FLUID TEMP SEN	<ul style="list-style-type: none"> <li>Excessively low supply voltage to TCM during driving</li> <li>Excessively high signal voltage of A/T fluid temperature sensor (excessively low A/T fluid temperature) during driving</li> <li><b>This message is displayed only when malfunction occurs with ignition switch ON, and does not have memory function.</b></li> </ul>	A/T fluid temperature sensor circuit, TCM power supply circuit, or throttle position sensor power supply circuit
ENGINE SPEED SIG	<ul style="list-style-type: none"> <li>Excessively low engine speed during driving</li> </ul>	Engine speed signal circuit
TURBINE SENSOR (Except RB20DE)	<ul style="list-style-type: none"> <li>TCM does not receive input shaft speed sensor signal due to open circuit, etc.</li> <li>TCM receives improper signal during driving.</li> </ul>	Turbine sensor circuit
SHIFT SOLENOID/V C (Except RB20DE)	<ul style="list-style-type: none"> <li>TCM does not receive shift solenoid A pressure detection switch signal due to open and/or short circuit.</li> </ul>	Shift solenoid A pressure detection switch circuit
MANUAL MODE SW (Except RB20DE)	<ul style="list-style-type: none"> <li>TCM does not receive proper manual mode switch signal due to open and/or short circuit.</li> </ul>	Manual mode switch circuit
ENGINE BRAKE C/U*1 (Except RB20DE)	<ul style="list-style-type: none"> <li>Shift control unit does not operate properly due to open and/or short circuit of each input/output signal wire.</li> <li>Malfunction occurs in shift control unit.</li> </ul>	Each signal wire circuit connected to shift control unit
*INITIAL START*	<ul style="list-style-type: none"> <li>Power supply to TCM is shut down, and self-diagnostic memory function is canceled due to battery removal, etc.</li> </ul>	
CONTROL UNIT (RAM)	<ul style="list-style-type: none"> <li>Malfunction is detected in TCM memory (RAM) function.</li> </ul>	
CONTROL UNIT (ROM)	<ul style="list-style-type: none"> <li>Malfunction is detected in TCM memory (ROM) function.</li> </ul>	

\*1: Indicates shift control unit.

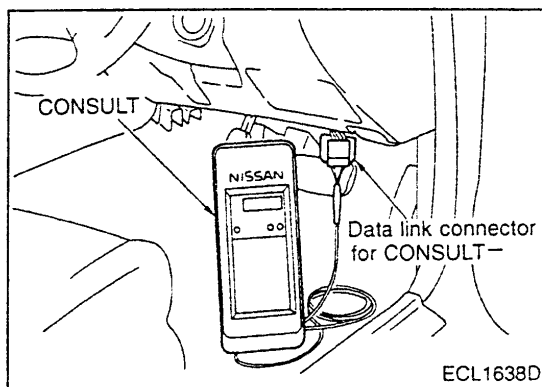

### DATA MONITOR PROCEDURE

Refer to "CONSULT Instruction Manual — Supplement" and "CONSULT Service Manual — Supplement" in details.

1. Turn ignition switch OFF.
2. Connect CONSULT connector to data link connector.
3. Turn ignition switch ON.
4. Touch "START", "A/T" and "DATA MONITOR" sequentially on CONSULT screen.



# TROUBLE DIAGNOSES

## CONSULT (Cont'd)

### DATA MONITOR MODE (A/T)

Item	Display	Monitor item		Description	Remarks
		ECU input signals	Main signals		
Vehicle speed sensor 1 (A/T) (Revolution sensor)	VHCL/S SE-A/T [km/h] or [mph]	X	—	<ul style="list-style-type: none"> <li>Vehicle speed computed from signal of revolution sensor is displayed.</li> </ul>	When racing engine in "N" or "P" position with vehicle stationary, CONSULT data may not indicate 0 km/h (0 mph).
Vehicle speed sensor 2 (Meter)	VHCL/S SE-MTR [km/h] or [mph]	X	—	<ul style="list-style-type: none"> <li>Vehicle speed computed from signal of vehicle speed sensor is displayed.</li> </ul>	Vehicle speed display may not be accurate under approx. 10 km/h (6 mph). It may not indicate 0 km/h (0 mph) when vehicle is stationary.
Throttle position sensor	THRTL POS SEN [V]	X	—	<ul style="list-style-type: none"> <li>Throttle position sensor signal voltage is displayed.</li> </ul>	
A/T fluid temperature sensor	FLUID TEMP SE [V]	X	—	<ul style="list-style-type: none"> <li>A/T fluid temperature sensor signal voltage is displayed.</li> <li>Signal voltage lowers as fluid temperature rises.</li> </ul>	
Battery voltage	BATTERY VOLT [V]	X	—	<ul style="list-style-type: none"> <li>Source voltage of TCM is displayed.</li> </ul>	
Engine speed	ENGINE SPEED [rpm]	X	X	<ul style="list-style-type: none"> <li>Engine speed, computed from engine speed signal, is displayed.</li> </ul>	Engine speed display may not be accurate under approx. 800 rpm. It may not indicate 0 rpm even when engine is not running.
Turbine revolution sensor	TURBINE REV [rpm]	X	—	<ul style="list-style-type: none"> <li>Turbine revolution computed from signal of turbine revolution sensor is displayed.</li> </ul>	Error may occur under approx. 800 rpm and will not indicate 0 rpm even if engine is not running.
Overdrive control switch	OVERDRIVE SW [ON/OFF]	X	—	<ul style="list-style-type: none"> <li>ON/OFF state computed from signal of overdrive control SW is displayed.</li> </ul>	
P/N position switch	P/N POSI SW [ON/OFF]	X	—	<ul style="list-style-type: none"> <li>ON/OFF state computed from signal of P/N position SW is displayed.</li> </ul>	
R position switch	R POSITION SW [ON/OFF]	X	—	<ul style="list-style-type: none"> <li>ON/OFF state computed from signal of R position SW is displayed.</li> </ul>	
D position switch	D POSITION SW [ON/OFF]	X	—	<ul style="list-style-type: none"> <li>ON/OFF state computed from signal of D position SW is displayed.</li> </ul>	
2 position switch	2 POSITION SW [ON/OFF]	X	—	<ul style="list-style-type: none"> <li>ON/OFF status, computed from signal of 2 position SW, is displayed.</li> </ul>	
1 position switch	1 POSITION SW [ON/OFF]	X	—	<ul style="list-style-type: none"> <li>ON/OFF status, computed from signal of 1 position SW, is displayed.</li> </ul>	
ASCD cruise signal	ASCD-CRUISE [ON/OFF]	X	—	<ul style="list-style-type: none"> <li>Status of ASCD cruise signal is displayed.</li> <li>ON ... Cruising state</li> <li>OFF ... Normal running state</li> </ul>	<ul style="list-style-type: none"> <li>This is displayed even when no ASCD is mounted.</li> </ul>
ASCD OD cut signal	ASCD-OD CUT [ON/OFF]	X	—	<ul style="list-style-type: none"> <li>Status of ASCD OD release signal is displayed.</li> <li>ON ... OD released</li> <li>OFF ... OD not released</li> </ul>	<ul style="list-style-type: none"> <li>This is displayed even when no ASCD is mounted.</li> </ul>
Kickdown switch	KICKDOWN SW [ON/OFF]	X	—	<ul style="list-style-type: none"> <li>ON/OFF status, computed from signal of kickdown SW, is displayed.</li> </ul>	<ul style="list-style-type: none"> <li>This is displayed even when no kickdown switch is equipped.</li> </ul>
A/T mode switch	POWERSHIFT SW [ON/OFF]	X	—	<ul style="list-style-type: none"> <li>ON/OFF status, computed from signal of HOLD shift SW, is displayed.</li> </ul>	
Closed throttle position switch	CLOSED THL/SW [ON/OFF]	X	—	<ul style="list-style-type: none"> <li>ON/OFF status, computed from signal of closed throttle position SW, is displayed.</li> </ul>	
Wide open throttle position switch	W/O THRL/P-SW [ON/OFF]	X	—	<ul style="list-style-type: none"> <li>ON/OFF status, computed from signal of wide open throttle position SW, is displayed.</li> </ul>	

G1

EC

AT

BR

ST

RS

HA

EL

SD

# TROUBLE DIAGNOSES

## CONSULT (Cont'd)

Item	Display	Monitor item		Description	Remarks
		ECU input signals	Main signals		
Shift solenoid A	SHIFT S/V A [ON/OFF]	—	—	● Indicates check signal (reentrant signal) status for TCM control signal output. ON/OFF status of shift solenoid is not changed when thermal insulation or short-circuit occurs in these valves.	
Shift solenoid B	SHIFT S/V B [ON/OFF]	—	—		
Overrun clutch solenoid	OVERRUN/C S/V [ON/OFF]	—	—		
Overrun clutch solenoid 2 (Except RB20DE)	OVERRUN/C S/V2 [ON/OFF]	—	—		
HOLD/SNOW switch	HOLD SW [ON/OFF]	X	—	● A/T mode switch - SNOW mode	
Manual mode switch (Except RB20DE)	MANU MODE SW [ON/OFF]	X	—	● Gate side contact in manual mode switch	
Non-manual mode switch (Except RB20DE)	NON M MODE SW [ON/OFF]	X	—	● Non-gate side contact in manual mode switch	
UP switch (Except RB20DE)	UP SW [ON/OFF]	X	—	● UP (+) side contact in manual mode switch	
DOWN switch (Except RB20DE)	DOWN SW [ON/OFF]	X	—	● DOWN (-) side contact in manual mode switch	
Non-shift switch (Except RB20DE)	NON SHIFT SW [ON/OFF]	—	—		
Brake switch	BRAKE SW [ON/OFF]	X	—	● Stop lamp switch	
Shift solenoid valve A (P switch) (Except RB20DE)	SHIFT S/V A [ON/OFF]	—	—	● Shift solenoid A pressure detection switch	
Gear position	GEAR	—	X	● Gear position data used for computation by TCM, is displayed.	
Selector lever position	SLCT LVR POSI	—	X	● Selector lever position data, used for computation by TCM, is displayed.	● A specific value used for control is displayed if fail-safe is activated due to error.
Vehicle speed	VEHICLE SPEED [km/h] or [mph]	—	X	● Vehicle speed data, used for computation by TCM, is displayed.	
Throttle position	THROTTLE POSI [°]	—	X	● Throttle position data, used for computation by TCM, is displayed.	● A specific value used for control is displayed if fail-safe is activated due to error.
Line pressure duty	LINE PRES DTY [%]	—	X	● Control value of line pressure solenoid valve, computed by TCM from each input signal, is displayed.	
Torque converter clutch solenoid valve duty	TCC S/V DUTY [%]	—	X	● Control value of torque converter clutch solenoid valve, computed by TCM from each input signal, is displayed.	
Shift solenoid valve A	SHIFT S/V A [ON/OFF]	—	X	● Control value of shift solenoid valve A, computed by TCM from each input signal, is displayed.	Control value of solenoid is displayed even if solenoid circuit is disconnected. The "OFF" signal is displayed if solenoid circuit is shorted.
Shift solenoid valve B	SHIFT S/V B [ON/OFF]	—	X	● Control value of shift solenoid valve B, computed by TCM from each input signal, is displayed.	
Overrun clutch solenoid valve	OVERRUN/C S/V [ON/OFF]	—	X	● Control value of overrun clutch solenoid valve computed by TCM from each input signal is displayed.	
Power shift lamp	POWER SFT LMP [ON/OFF]	—	X	● Control status of TCM power shift lamp	
Voltage	VOLTAGE [V]	—	—	● Indicates measurement value of voltage probe.	
Pulse	PULSE [msec, Hz or %]	—	—		

X: Applicable  
—: Not applicable

# TROUBLE DIAGNOSES

## Self-diagnosis

### DESCRIPTION

If malfunction should occur in electrical systems, turning ignition switch ON lights A/T mode switch POWER indicator lamp (M-AT: Dual matic A/T warning lamp) for 2 seconds, and then flashes the indicator lamp for 8 seconds. If malfunction does not occur, A/T mode switch POWER indicator lamp (M-AT: Dual matic A/T warning lamp) is turned on for 2 seconds upon turning ignition switch ON. To locate and display the malfunctioning part, output the trouble information memory and flash A/T mode switch POWER indicator lamp (M-AT: Dual matic A/T warning lamp) by inputting self-diagnostic startup signal.

### SELF-DIAGNOSIS PROCEDURE

#### 4AT

1. Warm up engine.
2. Repeat ON-OFF cycles of ignition switch for more than once, and turn it OFF at last.
3. Move A/T mode switch to AUTO, and turn overdrive control switch to O/D ON.
4. Turn ignition switch ON with selector lever in "P" position, and ensure POWER indicator lamp is turned on for 2 seconds.
5. Turn ignition switch OFF.
6. Move selector lever to "D" position.
7. Turn overdrive control switch O/D OFF.
8. Turn ignition switch ON.
9. Move selector lever to "2" position.
10. Turn overdrive control switch O/D ON.
11. Move selector lever to "1" position.
12. Turn overdrive control switch O/D OFF.
13. Depress accelerator pedal fully, and release it.
14. Read flashing status of POWER indicator lamp to complete self-diagnosis procedures.

#### M-AT

1. Warm up engine.
2. Repeat ON-OFF cycles of ignition switch for more than once, and turn it OFF at last.
3. Turn ignition switch ON with selector lever in "P" position, and ensure dual matic A/T warning lamp is turned on for 2 seconds.
4. Turn ignition switch OFF.
5. Depress brake pedal, release accelerator pedal, and then move selector lever to "D" position.
6. Turn ignition switch ON.
7. Release brake pedal, and move selector lever to "3" position.
8. While depressing brake pedal with left foot, depress accelerator pedal fully with right foot, and move selector lever to "2" position.
9. Read dual matic A/T warning lamp indication to complete self-diagnosis procedures.

# TROUBLE DIAGNOSES

## Self-diagnosis (Cont'd)

### POWER INDICATOR LAMP OR DUAL MATIC A/T WARNING LAMP INDICATION

If malfunction occurs in electrical system, indicator lamp stays on longer at corresponding circuit.

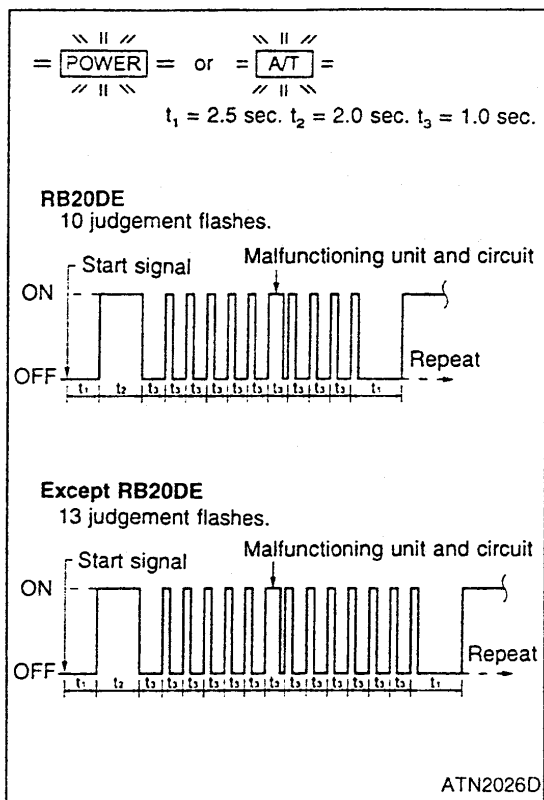

Flashing order	Malfunctioning unit and circuit	
	RB20DE	Except RB20DE
1	Vehicle speed sensor 1	
2	Vehicle speed sensor 2	
3	Throttle position sensor	
4	Shift solenoid A	
5	Shift solenoid B	
6	Overrun clutch solenoid	
7	Lock-up solenoid	
8	A/T fluid temperature sensor, TCM power supply, or throttle position sensor power supply	
9	Engine speed signal	
10	Line pressure solenoid	Turbine sensor
11	—	Line pressure solenoid
12	—	Total control signal
13	—	Shift control unit
No flashes	PNP switch, idle switch/full switch	
	Overdrive control switch	Stop lamp switch

- When indicator lamp repeats flashing in 4 Hz, the following malfunctions may exist: (Insufficient memory backup power/TCM replacement/Battery has been disconnected for prolonged period/Low battery power)

### HOW TO ERASE SELF-DIAGNOSTIC RESULTS

To facilitate cause investigation of malfunction that is less likely to reappear, the TCM always stores self-diagnostic results during customer operation. This memory cannot be erased even if ignition switch is turned ON and OFF repeatedly. To erase the self-diagnostic results, turn ignition switch OFF after self-diagnosis has been performed, or use "ERASE" function of CONSULT.

# TROUBLE DIAGNOSES

## Symptom Chart

Malfunctions	Sharp shock in shifting				Slip (Racing)									Engine brake applied					
	"N" position to "D" position	Shifting			Shifting			Shifting (Accelerator pedal depressed)			Vehicle will not run in "D" "2" "1" positions. Or excessively poor acceleration Vehicle will not run in "R" position. Or excessively poor acceleration			Shifting					
		1st to 2nd	2nd to 3rd	3rd to 4th	"1" position: 2nd to 1st	1st to 2nd	2nd to 3rd	3rd to 4th	4th to 3rd	4th to 2nd				3rd to 2nd	4th to 1st, 3rd to 1st	Startup	1st to 2nd	2nd to 3rd	3rd to 4th
Inspection item																			
Fluid level and status					1	1	1	1	1	1	1	1	1	1	1	1	1	1	1
Control linkage															2				2
PNP switch (short/open circuit)																			
Throttle position sensor (installed)	2	1	1	1	2	2	2	2	2	2	2			3					
Vehicle speed sensor																			
Engine speed sensor	5																		
A/T fluid temperature sensor	4	5																	
Engine idle speed	1																		
Line pressure	3	2	2	2	3	3	3	3	3	3	3	2	2	4				3	
Control valve assembly	7	4	4	4	1	5	5	5	5	6	5	5	4	4	6			5	
Shift solenoid A									5										
Shift solenoid B																			
Line pressure solenoid	6							4	4	4	4	3	3	5				4	
Lock-up solenoid																			
Overrun clutch solenoid										8									
Accumulator N-D	8											5		7					
Accumulator 1-2		3			4														
Accumulator 2-3			3			4					10								
Accumulator 3-4 (N-R)				3			4							8					
Ignition coil and starter motor																			
Overdrive control switch																			
A/T mode switch (AUTO)																			
A/T mode switch (POWER)																			
A/T mode switch (SNOW)																			
Torque converter															13				
Oil pump															12				
Reverse clutch												6	5	10	2		4		
High clutch			5					6		9		7	6		4			6	
Forward clutch	9					6	6	7	8	7	6	8	7	9				8	
Forward one-way clutch											7	9						3	
Overrun clutch				7									8					2	9
Low one-way clutch				6							8	10			5				
Low reverse brake					2								9	11	3				
Brake band (including servo)		6	6	5		6	7	7		7	6						2		7
Parking linkage																			

On-vehicle inspection

Off-vehicle inspection

 CI  
EC  
**AT**  
BR  
ST  
PS  
HA  
EL  
SD

# Symptom Chart (Cont'd)

Malfunctions	No shifting									Shifting		Greater noise							
	4th to 3rd	4th to 2nd, 3rd to 2nd	3rd to 1st, 2nd to 1st	1st to 2nd	2nd to 3rd	3rd to 4th	"2" position: 3rd to 2nd	"1" position: 2nd to 1st	Overdrive control switch ON: to 4th	1st to 3rd	"1" position: 1st to 2nd "2" position: 2nd to 3rd	At idle (vehicle stopped)	"D", "2", "1", "R" positions						
Inspection item																			
On-vehicle inspection	Fluid level and status	1	1	1						1		1	1			1			
	Control linkage				2	2	3	7			2								
	PNP switch (short/open circuit)				1	1	1	1	1	2	1			3					
	Throttle position sensor (installed)	2	2	2				2		1		3		1	1	2	1	1	
	Vehicle speed sensor				5	5	5		2	3		4		2	2		2	2	
	Engine speed sensor											5		4					
	A/T fluid temperature sensor						6			7				5					
	Engine idle speed																		
	Line pressure									8		2		6		3			
	Control valve assembly	6	5	6	4	4		6	4	6				8	4	6			
	Shift solenoid A	4	3	4	3		4	5	3	4									4
	Shift solenoid B		4	5		3		4											5
	Line pressure solenoid	5														5			
	Lock-up solenoid													7	3	4			
	Overrun clutch solenoid	3						3	5	5									
	Accumulator N-D																		
	Accumulator 1-2									2									
	Accumulator 2-3																		
	Accumulator 3-4 (N-R)																		
	Ignition coil and starter motor																		
	Overdrive control switch						2												
	A/T mode switch (AUTO)																		
	A/T mode switch (POWER)																	3	
	A/T mode switch (SNOW)			3															3
	Off-vehicle inspection	Torque converter										7	2	9		7			
		Oil pump										6							
		Reverse clutch																	
		High clutch		6	8														
Forward clutch																			
Forward one-way clutch																			
Overrun clutch		8						9	7	10									
Low one-way clutch				7					6										
Low reverse brake		7							9										
Brake band (including servo)			7	9	6	6	7	8	8	9	3								
Parking linkage																			

# TROUBLE DIAGNOSES

## Symptom Chart (Cont'd)

Inspection item	Malfunctions		Accelerator pedal is depressed at 4th speed.															
	No down-shifts (Within kickdown limit)	Down-shift or engine overrunning (Beyond kickdown limit)	Engine brake is not applied in "1" position.	Shift shock is felt during coasting.	Lower maximum speed or poor acceleration	Engine stop when shifting to running gears	Vehicle will not run in "D" and "2" positions (but runs in "1" and "R" positions).	Vehicle will not run in any positions.	Vehicle runs in "N" position.	Engine does not start in "N" and "P" positions.	Engine starts in positions other than "N" and "P".	Vehicle creeps in "P" position, or parking gear cannot be disengaged from "P" position.	Vehicle creeps excessively.	Vehicle does not creep at all.	Transaxle overheats.	A/T fluid spouts out or white smoke is emitted from exhaust pipe during operation.	Offensive smell at fluid charging pipe.	Engine stalls.
Fluid level and status					1		1						1	1	1	1	1	1
Control linkage			2			1	2	1	2	1	1							
PNP switch (short/open circuit)			1	2					3	2								
Throttle position sensor (installed)	1	2	3	1										3				
Vehicle speed sensor	2	1	4															
Engine speed sensor																		
A/T fluid temperature sensor																		
Engine idle speed						1						1		2				
Line pressure				2			3						2	4				
Control valve assembly			6	4	5	3							3	6				5
Shift solenoid A	3	3	5	3														4
Shift solenoid B	4	4		4														3
Line pressure solenoid							4							5				
Lock-up solenoid						2												2
Overrun clutch solenoid			7	3														
Accumulator N-D																		
Accumulator 1-2																		
Accumulator 2-3																		
Accumulator 3-4 (N-R)								4										
Ignition coil and starter motor									1									
Overdrive control switch																		
A/T mode switch (AUTO)																		
A/T mode switch (POWER)																		
A/T mode switch (SNOW)																		
Torque converter					11	4	9						6	14		2		
Oil pump					10		5						5	7		3		
Reverse clutch					6			3						8	2	4		
High clutch					7		6							9	3	5		
Forward clutch								2					4	11	5	7		
Forward one-way clutch																		
Overrun clutch			8											12	6	8		
Low one-way clutch							2											
Low reverse brake			9	9			8							13	7	9		
Brake band (including servo)				8			7							10	4	6		
Parking linkage							10				2							

G  
 C  
**AT**  
 BR  
 ST  
 RS  
 HA  
 EL  
 SD

# BRAKE SYSTEM

## SECTION **BR**

GI

EC

AT

**BR**

ST

RS

HA

EL

SD

## CONTENTS

<b>ANTI-LOCK BRAKE SYSTEM</b> .....	2	Component Parts Location .....	19
Fail-Safe Function.....	2	Circuit Diagram .....	20
System Diagram .....	2	Control Unit Input/Output Signal Specifications .....	21
Circuit Diagram .....	3	Precautions for Trouble Diagnosis .....	26
Component Parts Location .....	4	Basic Inspection.....	26
Control Unit Input/Output Signal Specifications .....	5	CONSULT for TCS/ABS Control Unit Control System .....	27
Precautions for Trouble Diagnosis .....	7	Self-diagnosis for TCS/ABS Control Unit Control System .....	34
Basic Inspection.....	7	CONSULT for Throttle Control Unit Control System .....	37
CONSULT .....	8	Self-diagnosis for Throttle Control Unit Control System .....	41
Self-diagnosis .....	14		
<b>TCS/ABS SYSTEM</b> .....	17		
System Description.....	17		
System Diagram .....	18		



# ANTI-LOCK BRAKE SYSTEM

## Fail-Safe Function

If any malfunction is detected in the system, the ABS warning lamp in the instrument panel is turned on with the ABS deactivated and the vehicle's brake system reverts to normal operation.

## System Diagram

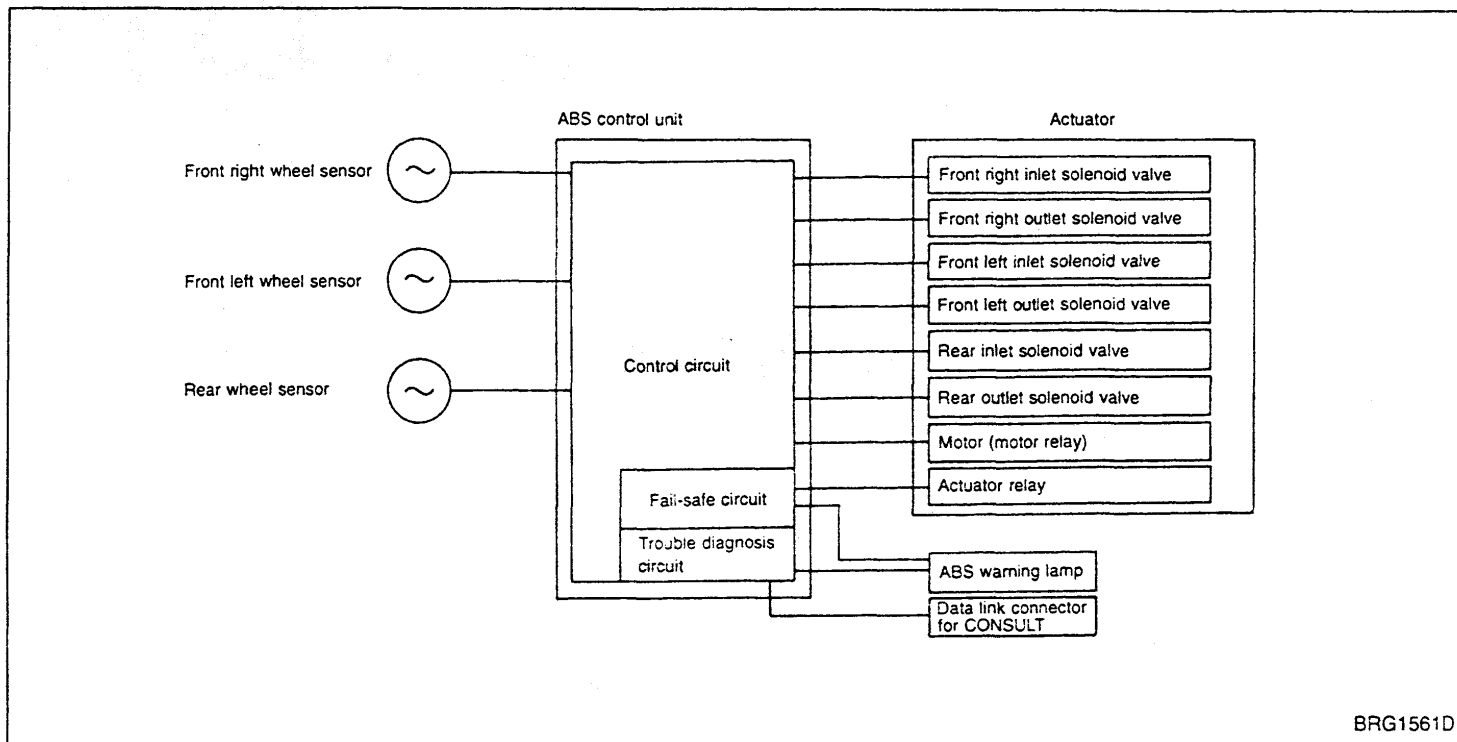

BRG1561D

# ANTI-LOCK BRAKE SYSTEM

## Circuit Diagram

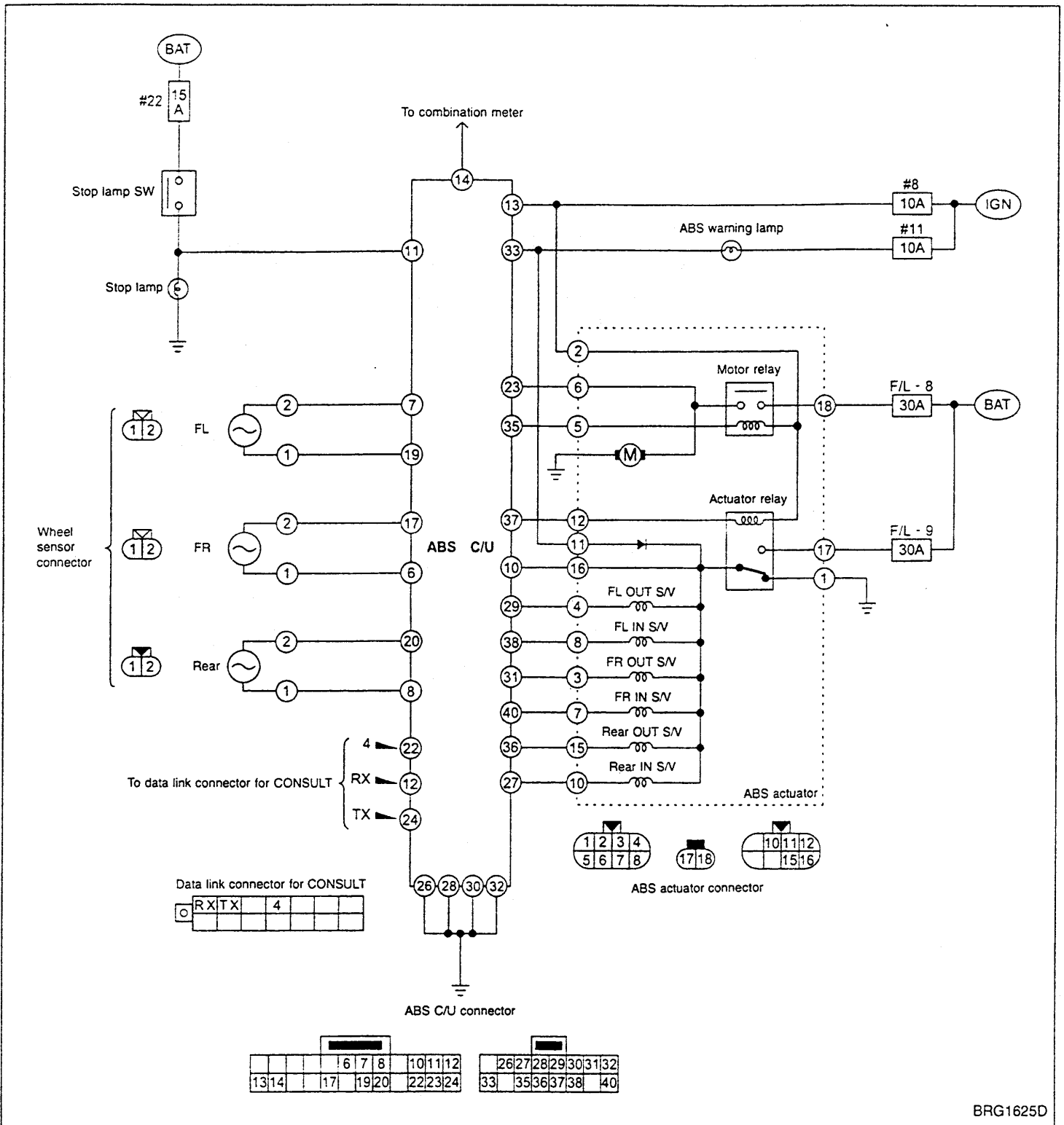

BRG1625D

GI  
EC  
AT  
BR  
ST  
RS  
HA  
EL  
SD

# ANTI-LOCK BRAKE SYSTEM

## Component Parts Location

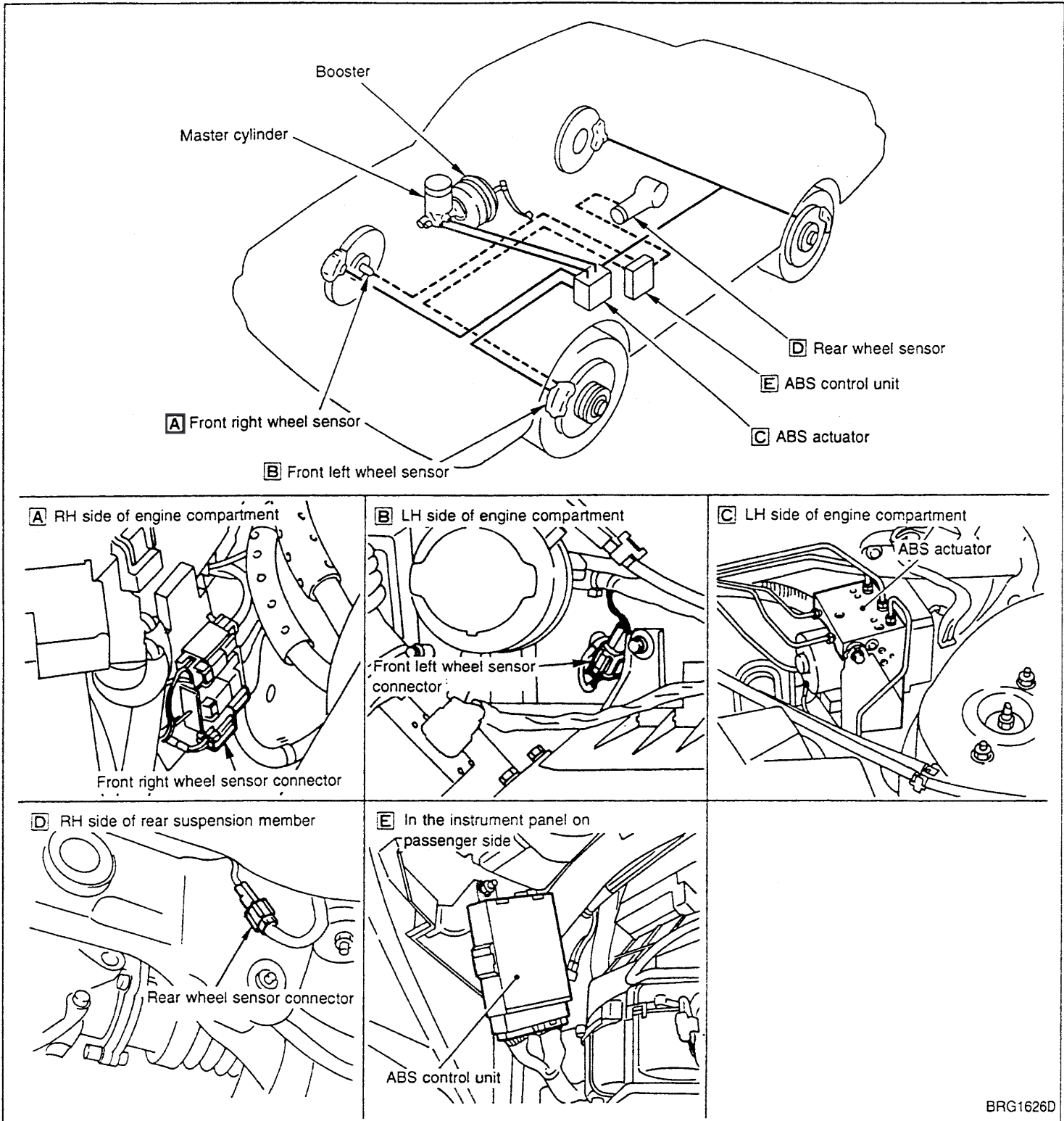

BRG1626D

# ANTI-LOCK BRAKE SYSTEM

## Control Unit Input/Output Signal Specifications

### USING CIRCUIT TESTER

To perform the following inspection, the ignition switch should be turned ON with ABS control unit connector and actuator connector properly connected.

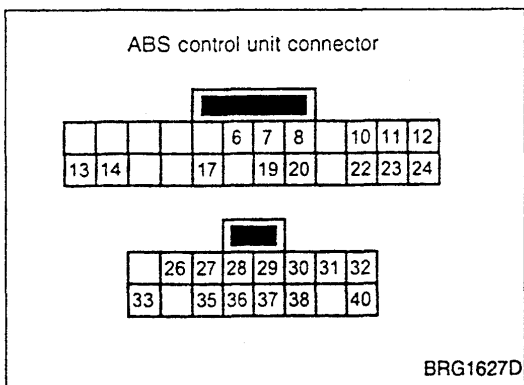

Terminal No.		Item	Specifications*1	Check item (Reference)
+	-			
13		Battery	Ignition switch ON: Battery voltage (Approx. 12V)	Control unit power supply circuit
11		Stop lamp signal	Brake pedal is depressed: Battery voltage (Approx. 12V) Brake pedal is not depressed: Less than approx. 2V	Stop lamp switch and circuit
35		ABS motor relay	ABS motor is running (in CONSULT active test mode): Less than approx. 2V ABS motor is stopped: Battery voltage (Approx. 12V)	ABS motor, motor relay and circuit
37		Actuator relay	Actuator relay is activated (with engine running): Less than approx. 2V Actuator relay is not activated (with fail-safe function activated and engine not running): Battery voltage (Approx. 12V)	ABS actuator relay and circuit
10		Actuator relay monitor	Actuator relay is activated (with engine running): Battery voltage (Approx. 12V) Actuator relay is not activated (with fail-safe function activated and engine not running): Approx. 0V	ABS warning lamp and circuit, ABS actuator relay monitor circuit
40	Body ground	Front right inlet solenoid	Actuator is activated (in CONSULT active test mode), or actuator relay is not activated (with fail-safe function activated and engine not running): Approx. 0V	ABS solenoid and circuit
27		Rear inlet solenoid		
38		Front left inlet solenoid		
23		ABS motor monitor	ABS motor is running (in CONSULT active test mode): Battery voltage (Approx. 12V) ABS motor is stopped (with ignition switch ON): Approx. 0V	ABS motor monitor circuit
33		ABS warning lamp	ABS warning lamp ON*2: Approx. 0V ABS warning lamp OFF*2: Battery voltage (Approx. 12V)	ABS warning lamp and circuit
17		Front right wheel sensor	Wheels are turning (Approx. 30 km/h)*3: Pulse generates. Front: Approx. 200 Hz Rear: Approx. 400 Hz	Wheel sensors and circuit
7		Front left wheel sensor		
20		Rear wheel sensor		
31		Front right outlet solenoid	Actuator is activated (in CONSULT active test mode), or actuator relay is not activated (with fail-safe function activated and engine not running): Approx. 0V Actuator is not activated and actuator relay is activated (with vehicle stopped and engine running): Battery voltage (Approx. 12V)	ABS solenoid and circuit
36		Rear outlet solenoid		
29		Front left outlet solenoid		

\*1: Do not force to open a connector terminal when using a circuit tester for inspection.

\*2: ABS warning lamp ON: When the ignition switch is turned ON (before starting the engine) or a malfunction is detected  
ABS warning lamp OFF: One second after the ignition switch is turned ON (with the system in normal condition)

\*3: Tire pressure must be in accordance with specification.

# ANTI-LOCK BRAKE SYSTEM

## Control Unit Input/Output Signal Specifications (Cont'd)

### USING CONSULT

Indicated are the control unit computed data. If the output circuit (harness) should be open or short-circuited, correct values may be displayed.

Display	Monitor item	Data monitor		Check item (Reference)
		Condition	Specifications	
FR RH SENSOR FR LH SENSOR RR SENSOR [km/h]	Wheel speed	Vehicle is stationary.	0 km/h	Wheel sensor and circuit
		Vehicle is driven.*1	Virtually the same speed as speedometer (within $\pm 10\%$ )	
STOP LAMP SW [ON-OFF]	Brake pedal status	Brake pedal is depressed.	ON	Stop lamp switch and circuit
		Brake pedal is not depressed.	OFF	
FR RH IN SOL FR LH IN SOL REAR IN SOL [ON-OFF]	Solenoid status	Actuator (solenoid) is activated (at CONSULT active test), or actuator relay is not activated (with fail-safe function activated and engine not running).	ON	ABS solenoid and circuit
		Actuator (solenoid) is not activated and actuator relay is activated (with vehicle stopped and engine running).	OFF	
FR RH OUT SOL FR LH OUT SOL REAR OUT SOL [ON-OFF]				
ACTUATOR RLY [ON-OFF]	Actuator relay status	Actuator relay is activated (with engine running).	ON	ABS actuator relay and circuit
		Actuator relay is not activated (with fail-safe function activated and engine not running).	OFF	
MOTOR RLY [ON-OFF]	Motor relay and motor status	Motor relay and motor are activated (at CONSULT active test).	ON	ABS motor, motor relay, and circuit
		Motor relay and motor are not activated.	OFF	
WARNING LAMP [ON-OFF]	ABS warning lamp status	Warning lamp ON*2	ON	ABS warning lamp and circuit
		Warning lamp OFF*2	OFF	
BATTERY VOLT [V]	Power supply voltage provided for control unit	Ignition switch ON	10 - 16V	Control unit power supply circuit

\*1: Tire pressure must be in accordance with specification.

\*2: ABS warning lamp ON: When the ignition switch is turned ON (before starting the engine) or a malfunction is detected  
ABS warning lamp OFF: One second after the ignition switch is turned ON (with the system in normal condition)

## Precautions for Trouble Diagnosis

- After performing trouble diagnosis, be sure to erase trouble stored in memory. Refer to "CONSULT" (next page) or "SELF-DIAGNOSIS" (BR-15).
- As for the concerns that are difficult to duplicate, move harnesses or harness connectors by hand to check if there is any poor mating of connector halves or faulty connection.
- Do not force to open a connector terminal when using a circuit tester for inspection.
- Read GI section thoroughly in advance and make sure of all the general precautions.

GI

EC

## Basic Inspection

### BASIC INSPECTION 1 — Brake fluid level and leakage

1. Check brake fluid level in reservoir tank. Replenish brake fluid if necessary.
2. Check for leakage at or around brake piping and ABS actuator. If leakage or seepage is noted, proceed as follows:
  - If ABS actuator connectors are loose, tighten to specified torque. Recheck to ensure that leakage is no longer present.
  - If flare nut threads at piping connectors or actuator threads are damaged, replace faulty parts with new ones. Recheck to ensure that leakage is no longer present.
  - If brake fluid leaks through areas other than actuator connectors, wipe off using a clean cloth. Recheck for leakage or seepage. If necessary, replace faulty parts with new ones.
  - If brake fluid leaks at or seeps through ABS actuator, wipe off using a clean cloth. Recheck for leakage or seepage. If necessary, replace ABS actuator with new one.

AT

BR

ST

RS

HA

#### CAUTION:

**ABS actuator cannot be disassembled. Do not attempt to disassemble it.**

### BASIC INSPECTION 2 — Loose power line terminal

Check battery terminals (positive and negative) and battery mounting (ground) for looseness.

EL

SD

### BASIC INSPECTION 3 — ABS warning lamp

1. Turn ignition switch "ON" to ensure that ABS warning lamp lights up for approximately 1 second. If ABS warning lamp does not light, check ABS warning lamp circuit.
2. After driving vehicle at approx. 30 km/h for approx. 1 minute, check to ensure that ABS warning lamp remains off. If ABS warning lamp lights, perform self-diagnosis procedures.
3. After performing self-diagnosis procedures, be sure to erase trouble stored in memory.

## CONSULT

### CONTROL UNIT PART NUMBER

The part number that is shown on the control unit label and CONSULT: 47850 AA000

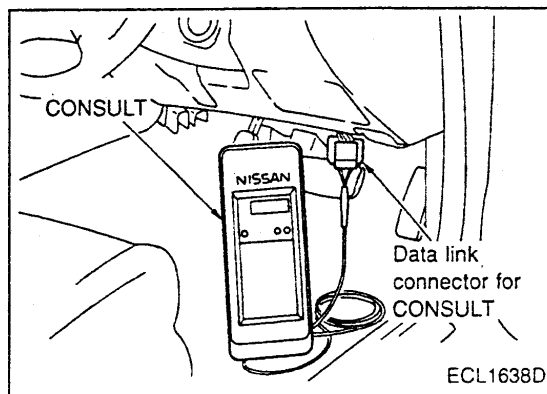

### SELF-DIAGNOSIS PROCEDURE

1. Collect information on the concern from the customer, and then perform basic inspections.
2. Turn ignition switch OFF and connect CONSULT connector to data link connector for CONSULT on the vehicle.
3. Start engine and drive vehicle at approx. 30 km/h for approx. 1 minute.
4. Stop vehicle and touch "START", "ABS" and "SELF-DIAG RESULTS" sequentially on the CONSULT screen with engine running.
  - If "START" is touched immediately after engine is started or ignition switch is turned on, "ABS" may not be displayed on "SELECT SYSTEM" screen. To display "ABS", repeat the self-diagnosis procedure from the beginning.
5. Self-diagnosis results are displayed on the screen. (Touch "PRINT" to print out the self-diagnosis results, if necessary.)
  - If "NO FAIL" is displayed, inspect ABS warning lamp. Refer to the previous page.
6. Perform appropriate inspection from the self-diagnostic results mode and repair or replace faulty parts.
7. Start engine and drive vehicle at approx. 30 km/h for approx. 1 minute.
  - **Recheck to ensure that there is no other malfunction.**
8. Turn ignition switch OFF to prepare for erasing the trouble stored in memory.
9. Start engine and touch "START", "ABS", "SELF-DIAG RESULTS" and "ERASE" sequentially on the CONSULT screen to erase the trouble stored in memory.
  - **If the trouble stored in memory is not erased, repeat step 6.**
10. Drive vehicle at approx. 30 km/h for approx. 1 minute and then confirm that ABS warning lamp is off.

# ANTI-LOCK BRAKE SYSTEM

## CONSULT (Cont'd)

### SELF-DIAGNOSTIC RESULTS MODE

Diagnostic item	Diagnostic item is detected when...	Check item
FR RH SENSOR [OPEN]	Circuit for front right wheel sensor is open. Or an abnormally high input voltage is entered due to short to battery.	Wheel sensor and circuit
FR LH SENSOR [OPEN]	Circuit for front left wheel sensor is open. Or an abnormally high input voltage is entered due to short to battery.	
REAR SENSOR [OPEN]	Circuit for rear wheel sensor is open. Or an abnormally high input voltage is entered due to short to battery.	
FR RH SENSOR [SHORT]*1, *2	Front right wheel sensor is short-circuited or shorted to ground, or gap between the wheel sensor and the sensor rotor is large. An abnormally low input voltage is entered and input signal is abnormal.	
FR LH SENSOR [SHORT]	Front left wheel sensor is short-circuited or shorted to ground, or gap between the wheel sensor and the sensor rotor is large. An abnormally low input voltage is entered and input signal is abnormal.	
REAR SENSOR [SHORT 1]*1, *2	Rear wheel sensor is short-circuited or shorted to ground, or gap between the wheel sensor and the sensor rotor is large. An abnormally low input voltage is entered and input signal is abnormal.	
FR RH IN ABS SOL [OPEN]	Circuit for front right inlet solenoid valve is open, or an output voltage is much lower than the specified value due to short to ground.	ABS solenoid and circuit
FR LH IN ABS SOL [OPEN]	Circuit for front left inlet solenoid valve is open, or an output voltage is much lower than the specified value due to short to ground.	
REAR IN ABS SOL [OPEN]	Circuit for rear inlet solenoid valve is open, or an output voltage is much lower than the specified value due to short to ground.	
FR RH IN ABS SOL [SHORT]	Circuit for front right inlet solenoid valve is shorted, or an output voltage is much higher than the specified value due to short to battery.	
FR LH IN ABS SOL [SHORT]	Circuit for front left inlet solenoid valve is shorted, or an output voltage is much higher than the specified value due to short to battery.	
REAR IN ABS SOL [SHORT]	Circuit for rear inlet solenoid valve is shorted, or an output voltage is much higher than the specified value due to short to battery.	
FR RH OUT ABS SOL [OPEN]	Circuit for front right outlet solenoid valve is open, or an output voltage is much lower than the specified value due to short to ground.	
FR LH OUT ABS SOL [OPEN]	Circuit for front left outlet solenoid valve is open, or an output voltage is much lower than the specified value due to short to ground.	
REAR OUT ABS SOL [SHORT]	Circuit for rear outlet solenoid valve is open, or an output voltage is much lower than the specified value due to short to ground.	
FR RH OUT ABS SOL [SHORT]	Circuit for front right outlet solenoid valve is shorted, or an output voltage is much higher than the specified value due to short to battery.	
FR LH OUT ABS SOL [SHORT]	Circuit for front left outlet solenoid valve is shorted, or an output voltage is much higher than the specified value due to short to battery.	
REAR OUT ABS SOL [SHORT]	Circuit for rear outlet solenoid valve is shorted, or an output voltage is much higher than the specified value due to short to battery.	
ABS MOTOR [ON FAILURE]	ABS motor turns ON when control unit sends OFF signal. ABS motor circuit is open or shorted to ground.	ABS motor, motor relay and circuit
ABS MOTOR [OFF FAILURE]	ABS motor turns OFF when control unit sends ON signal. Relay control wire is broken.	
ABS ACTUATOR RELAY [ON FAILURE]	ABS actuator relay turns ON when control unit sends OFF signal. Actuator relay is short-circuited to ground.	ABS actuator relay and circuit
ABS ACTUATOR RELAY [OFF FAILURE]	ABS actuator relay turns OFF when control unit sends ON signal. Relay control wire is broken.	

GI

EC

AT

BR

ST

RS

HA

EL

SD



# ANTI-LOCK BRAKE SYSTEM

## CONSULT (Cont'd)

Diagnostic item	Diagnostic item is detected when...	Check item
BATTERY VOLTAGE [VB-HIGH]	ABS control unit battery voltage is abnormally high.	Control unit power supply circuit
BATTERY VOLTAGE [VB-LOW]	ABS control unit battery voltage is abnormally low.	
CONTROL UNIT	Function of calculation in ABS control unit has failed.	Control unit, control unit power supply and ground circuit
ABS MOTOR [LOCK FAILURE]	ABS motor speed is abnormally low.	ABS motor, motor relay and circuit

\*1: ABS warning lamp turns on if a wheel or wheels spin for 10 to 80 seconds (depending on the wheel speed) with the vehicle stuck in snow, ice, or mud. This is a normal condition.

\*2: After repairing short-circuited sensor, turning ignition switch ON lights up ABS warning lamp. Check that ABS warning lamp turns off when the vehicle is driven at approx. 30 km/h for approx. 1 minute as shown in the self-diagnosis procedure.

**NOTE:**

If "ABS" is not displayed on "SELECT SYSTEM" screen, check ABS control unit and data link connector circuit, and make sure of the CONSULT card number.

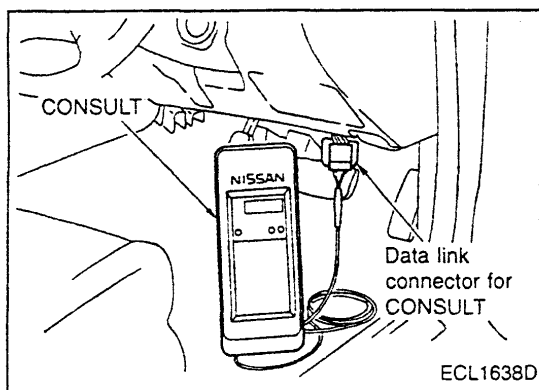

### DATA MONITOR PROCEDURE

- Refer to CONSULT Instruction Manual for details on data monitor function.
1. Turn ignition switch OFF.
  2. Connect CONSULT connector to data link connector for CONSULT.
  3. Turn ignition switch ON.
  4. Touch "START" on CONSULT screen.
  5. Touch "ABS" on CONSULT screen.
- If "START" is touched immediately after engine is started or ignition switch is turned on, "ABS" may not be displayed on "SELECT SYSTEM" screen. To display "ABS", repeat the data monitor procedure from the beginning.
6. Touch "DATA MONITOR".
  7. Touch "SETTING" to set recording condition.
  8. Touch "AUTO TRIG", "LONG TIME" and then "ENTER".
  9. Return to "SELECT MONITOR ITEM" screen and touch "C/U INPUT ITEM", "ALL SIGNALS" or "SELECTION FROM MENU". Refer to "DATA MONITOR MODE" on the next page.
  10. Touch "START".
  11. Display data monitor.
  12. If necessary, sequentially touch "REC START", "REC STOP", "DATA DISPLAY", "NUMBER PRINT" and "PRINT" to print out the data.

# ANTI-LOCK BRAKE SYSTEM

## CONSULT (Cont'd)

### DATA MONITOR MODE

MONITOR ITEM	CONDITION	SPECIFICATION
FR RH SENSOR FR LH SENSOR RR SENSOR	Drive vehicle. (Each wheel is rotating.)	Displays computed vehicle speed from wheel sensor signal. Almost the same speed as speedometer.
STOP LAMP SW	Turn ignition switch ON and depress brake pedal.	Depress the pedal: ON Release the pedal: OFF
FR RH IN SOL FR RH OUT SOL FR LH IN SOL FR LH OUT SOL REAR IN SOL REAR OUT SOL	Ignition switch is turned ON or engine is running.	Operating conditions for each solenoid valve are indicated. ABS is not operating: OFF
ACTUATOR RLY	Ignition switch is turned ON or engine is running.	Displays ON/OFF condition of ABS actuator relay. When turning ignition switch ON, ABS actuator relay is operated.
MOTOR RLY		ABS is not operating: OFF ABS is operating: ON
WARNING LAMP		Warning lamp is turned on: ON Warning lamp is turned off: OFF
BATTERY VOLT		Power supply voltage for control unit
VOLTAGE	Indicates the voltage measured with a voltage probe.	
PLS WIDTH-H	Refer to CONSULT Instruction Manual.	

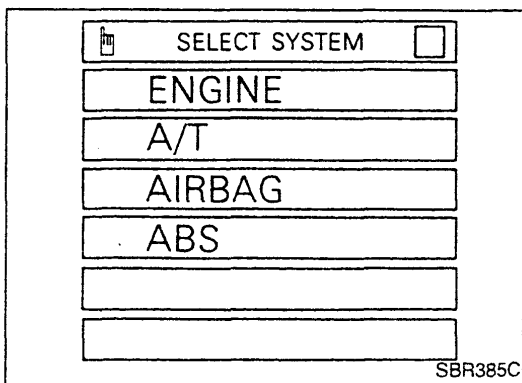
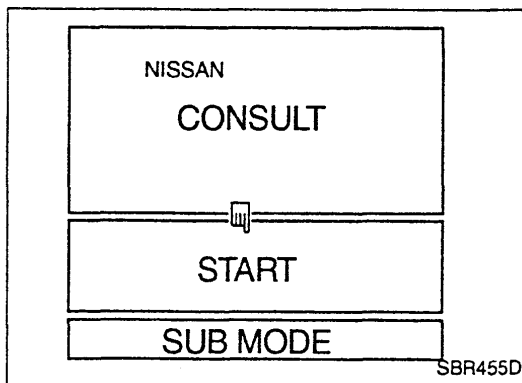

### ACTIVE TEST PROCEDURE

- When conducting Active test, vehicle must be stationary.
  - Confirm that brakes have been bled completely.
  - When ABS warning lamp stays on, never conduct Active test.
1. Turn ignition switch OFF.
  2. Connect CONSULT to Data Link Connector for CONSULT.
  3. Start engine.
  4. Touch "START" on CONSULT screen.
- 
5. Touch "ABS".

# ANTI-LOCK BRAKE SYSTEM

## CONSULT (Cont'd)

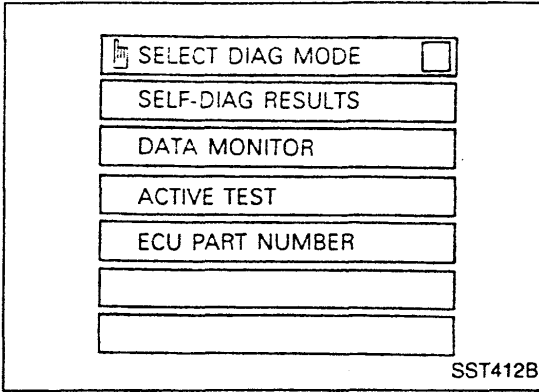

6. Touch "ACTIVE TEST".

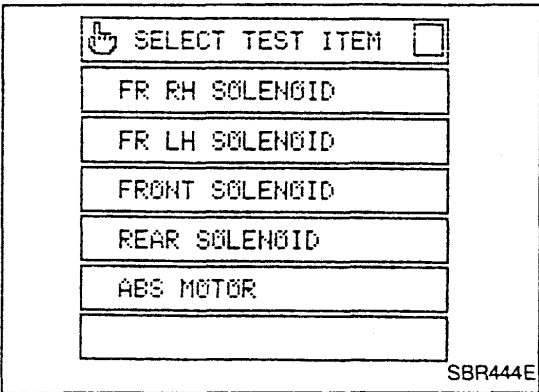

7. Select active test item by touching screen.

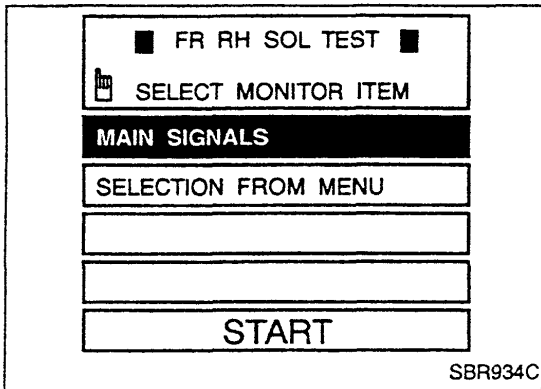

8. Touch "START".

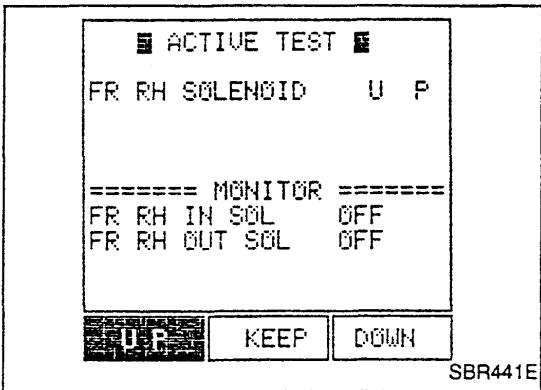

9. "ACTIVE TEST" screen is displayed.

### ABS solenoid valve

- To check that ABS solenoid valves (inlet and outlet) operate in the following manner, touch "UP", "KEEP" and "DOWN" on the screen while observing the monitor.

Operation	UP	KEEP	DOWN
IN ABS S/V	OFF	ON	ON
OUT ABS S/V	OFF	OFF	ON*

\*: Solenoid valve stays ON for 1 to 2 seconds after touching the key, and then turns OFF.

- If the active test is conducted with brake pedal depressed, the brake pedal travel limit may change. This is a normal condition.
- "TEST IS STOPPED" message is displayed 10 seconds after the operation is started.
- If the active test needs to be performed again after "TEST IS STOPPED" is displayed, repeat step 8.

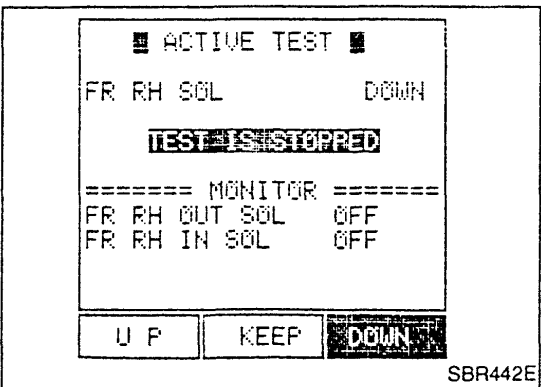

# ANTI-LOCK BRAKE SYSTEM

## CONSULT (Cont'd)

### ABS motor

- Touch "ON" and "OFF" on the screen to check that ABS motor relay and ABS actuator relay operate as follows:

Operation	ON	OFF
ABS actuator relay	ON	ON
ABS motor relay	ON	OFF

- If the active test is conducted with brake pedal depressed, the brake pedal travel limit may change. This is a normal condition.
- "TEST IS STOPPED" message is displayed 10 seconds after the operation is started.

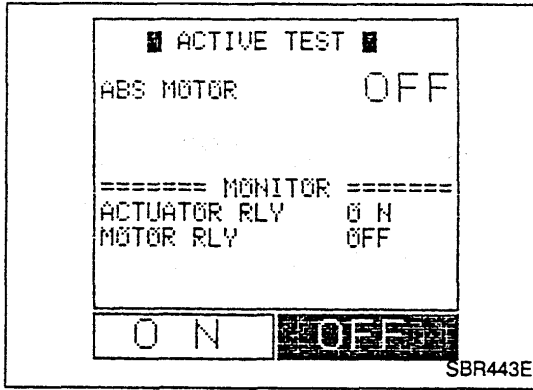

GI

EC

AT

BR

ST

RS

HA

EL

SD

## Self-diagnosis

### DESCRIPTION

When a problem occurs in the ABS, the ABS warning lamp on the instrument panel comes on. To actuate the self-diagnostic results mode, ground the self-diagnostic check terminal 4 located on the data link connector for CONSULT. The ABS warning lamp, then, flashes and indicates the location of the malfunction.

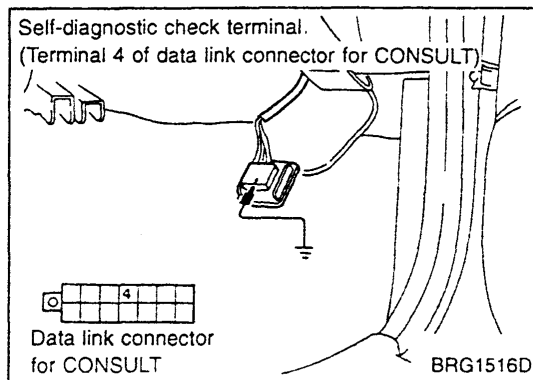

### SELF-DIAGNOSIS PROCEDURE

1. Collect information on the concern from the customer, and then perform basic inspections.
2. Drive vehicle at approx. 30 km/h for approx. 1 minute.
3. Stop vehicle and start diagnosis.
4. Turn ignition switch "OFF".
5. Ground the self-diagnostic check terminal 4.
6. Turn ignition switch "ON" to start the self-diagnostic results mode.

#### CAUTION:

- Keep terminal 4 grounded during self-diagnosis.
  - Do not depress brake pedal. (Self-diagnosis would not start.)
  - Do not start engine. (Self-diagnosis would not start.)
7. After 3 or 4 seconds, ABS warning lamp starts blinking to indicate the malfunction code No.
  - The indication terminates after 5 minutes. Turning the ignition switch from "OFF" to "ON" resumes blinking the indication.
  8. Verify the location of the malfunction with "MALFUNCTION CODE/SYMPTOM CHART", BR-16. Then make the necessary repairs.
  9. After the malfunctions are repaired, erase the malfunction codes stored in the control unit. Refer to "HOW TO ERASE SELF-DIAGNOSTIC RESULTS" on the next page.
  10. Rerun the self-diagnostic results mode to verify that the malfunction codes have been erased.
  11. Disconnect the check terminal from the ground. The self-diagnostic results mode is now complete.
  12. Drive vehicle at approx. 30 km/h for approx. 1 minute, and then check that the ABS warning lamp is off.

### HOW TO READ SELF-DIAGNOSTIC RESULTS (Malfunction codes)

- Determine the code No. by observing the time and the frequency that the ABS warning lamp blinks ON and OFF.
- When multiple malfunctions occur at a time, up to three code numbers can be stored; the latest malfunction will be indicated first.
- The indication begins with the start code No. 12. A maximum of three code numbers appear in the order of the latest one first. The indication then returns to the start code No. 12 to repeat.
- The start code No. 12 is only indicated repeatedly when there is no malfunction.

# ANTI-LOCK BRAKE SYSTEM

## Self-diagnosis (Cont'd)

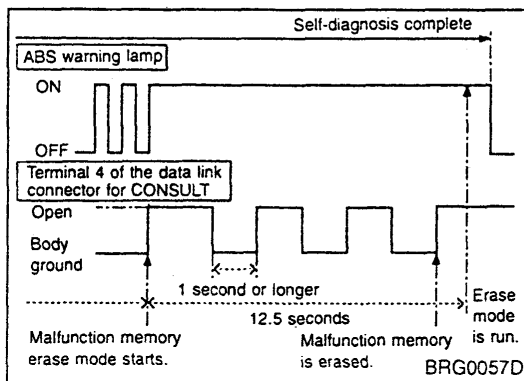
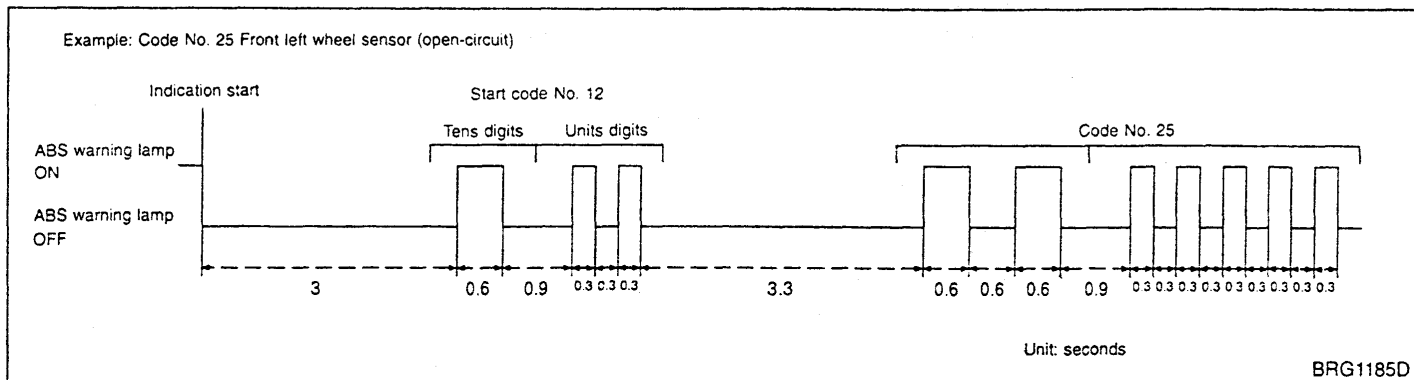

### HOW TO ERASE SELF-DIAGNOSTIC RESULTS (Malfunction codes)

1. Turn the ignition switch "ON" and start the engine.
2. Drive the vehicle at approx. 30 km/h for approx. 1 minute to check that there is no other malfunction.
3. Stop the vehicle.
4. Turn the ignition switch "OFF".
5. Ground the self-diagnostic check terminal.
6. Turn the ignition switch "ON" to start the self-diagnostic results mode.

#### CAUTION:

Do not depress the brake pedal during self-diagnosis. Do not start the engine. (The self-diagnosis would not start.)

7. The ABS warning lamp starts to blink 3 or 4 seconds after the self-diagnostic results mode is started.
8. Under the self-diagnostic results mode, the malfunction memory erase mode starts when the check terminal is disconnected from the ground.
9. Ground the check terminal 3 times or more in succession within 12.5 seconds after the erase mode starts. (Each grounding must be 1 second or longer.)
10. Disconnect the grounding cable from the check terminal to erase the malfunction memory and complete the self-diagnosis. The ABS warning lamp, then, turns off.
11. Turn the ignition switch "OFF".

# ANTI-LOCK BRAKE SYSTEM

## Self-diagnosis (Cont'd)

### MALFUNCTION CODE/SYMPTOM CHART

Malfunction code No.	Malfunctioning part		ABS warning lamp ON	Fail-safe operation
18	Different number of teeth of sensor rotors		○	○
21	Front right wheel sensor (open-circuit)		○	○
22	Front right wheel sensor (short-circuit)*4		○	○
25	Front left wheel sensor (open-circuit)		○	○
26	Front left wheel sensor (short-circuit)*4		○	○
31	Rear wheel sensor (open-circuit)		○	○
32	Rear wheel sensor (short-circuit)*4		○	○
41	Front right outlet ABS solenoid valve and circuit		○	○
42	Front right inlet ABS solenoid valve and circuit		○	○
45	Front left outlet ABS solenoid valve and circuit		○	○
46	Front left inlet ABS solenoid valve and circuit		○	○
55	Rear outlet ABS solenoid valve and circuit		○	○
56	Rear inlet ABS solenoid valve and circuit		○	○
57	Power supply (Low or high voltage)*2		○	—*1
61	ABS actuator motor or motor relay*3		○	○
63	ABS actuator relay		○	○
71	ABS control unit		○	○
No indication	At self-diagnosis only	ABS control unit or data link connector for CONSULT is poorly connected.	○	○
	Ignition switch ON	ABS control unit/Fuse is blown or ABS warning lamp has an open circuit.		
Stays ON	At self-diagnosis only	ABS control unit	○	○
	Ignition switch ON	ABS control unit/ABS actuator relay is stuck to OFF./ABS power supply circuit, ABS actuator relay drive side power supply (coil side) circuit, and ABS warning lamp circuit are short-circuited./ABS control unit connector is disconnected or poorly connected.		

\*1: Fail-safe operation does not activate. A signal from ABS control unit suspends ABS control operation. Brakes operate conventionally. After specified power supply voltage resumes, ABS warning lamp goes out, allowing for ABS control operation.

\*2: The code No. does not indicate a malfunction related to the ABS control unit. Do not replace the ABS control unit even if the code No. appears.

\*3: The code No. can sometimes appear when the ABS motor ground circuit is loose or disconnected. When it appears, always check the ground circuit for improper installation.

\*4: ABS warning lamp turns on if a wheel or wheels spin for 10 to 80 seconds (depending on the wheel speed) with the vehicle stuck in snow, ice, or mud. This is a normal condition. After repairing short-circuited sensor, turning ignition switch ON lights up ABS warning lamp. Check that ABS warning lamp turns off when the vehicle is driven at approx. 30 km/h for approx. 1 minute as shown in the self-diagnosis procedure.

## System Description

### ABS FUNCTION

1. During ABS operation, the brake pedal pulsates along with a mechanical noise. This ensures that the ABS is working properly.
2. When starting up the engine or immediately after the vehicle starts to run, the brake pedal pulsates and a motor noise from the engine compartment can be heard. They are caused by the ABS operation check and should not be considered abnormal.
3. A vehicle with the ABS may stop in a longer distance than a vehicle without the ABS when the brake is applied on a bad road, gravel road, or deep fresh snow.

### TCS FUNCTION

1. TCS/ABS control unit monitors the speed of the driving wheels through 4 wheel speed sensors. If driving wheel slip is detected, fuel to the engine is cut off and the throttle valve is adjusted so that the engine torque is reduced. On vehicles with automatic transmission, transmission shift schedule is also changed to control the rear wheel driving torque, which results in the reduction of wheel slip. This system enables the throttle valve to be controlled so that optimum engine torque can be achieved in accordance with the driver's acceleration request.
2. The driver may not feel satisfied with acceleration on some road surfaces. This poor acceleration occurs because the operating TCS gives priority to maintaining optimum traction. Therefore, this condition should be considered normal.
3. When shiftdown is made or the acceleration pedal is depressed while the vehicle is driven on the road surface that has different friction coefficients, the TCS may operate temporarily.
4. On vehicles with manual transmission, the SLIP indicator lamp and the TCS OFF indicator lamp may light up when the engine is about to stall in the conditions shown below. If the lamps go off when engine speed increases, there is no problem in the system.
  - At start, the engine almost stalls and the engine speed is much lower than the idle speed.
  - The vehicle is driven at an extremely low speed with a high-speed gear engaged.
  - The clutch has been engaged until the vehicle almost stops.

### FAIL-SAFE FUNCTION

#### ABS system

If any malfunction is detected in the system, the ABS warning lamp, the TCS OFF indicator lamp and the SLIP indicator lamp in the instrument panel is turned on with the TCS/ABS deactivated and the vehicle's brake system reverts to normal operation.

#### TCS system

If any malfunction is detected in the system, both the SLIP indicator lamp and the TCS indicator lamp on the instrument panel light up and the TCS is shut down. The vehicle operates in the same manner as a vehicle without the TCS, while the ABS is operational.

- If there is a malfunction in the throttle control system, the TCS becomes inoperative while the ABS remains functional.
- When fail-safe operation is activated, perform the self-diagnosis procedure for the TCS/ABS first. Refer to BR-27 for details.



# TCS/ABS SYSTEM

## System Description (Cont'd)

### Parts that make throttle control inoperative

Malfunction code No.	Malfunctioning part
11	Throttle position sensor circuit
12	Throttle motor sensor circuit
13	Circuit for the communication line (DKR line) between TCS/ABS control unit and throttle control unit
21	Actuator system (Motor circuit is open or throttle motor intermittently works.)
22	Throttle motor drive system (overcurrent)
23	Throttle motor relay circuit (shorted)
24	Throttle motor relay circuit (open)
32	Throttle motor return spring (Return spring is broken.)

### Parts that make throttle control operative

Malfunction code No.	Malfunctioning parts
31	Starter signal circuit (shorted)
33	Park/neutral position switch circuit (open or shorted)

## System Diagram

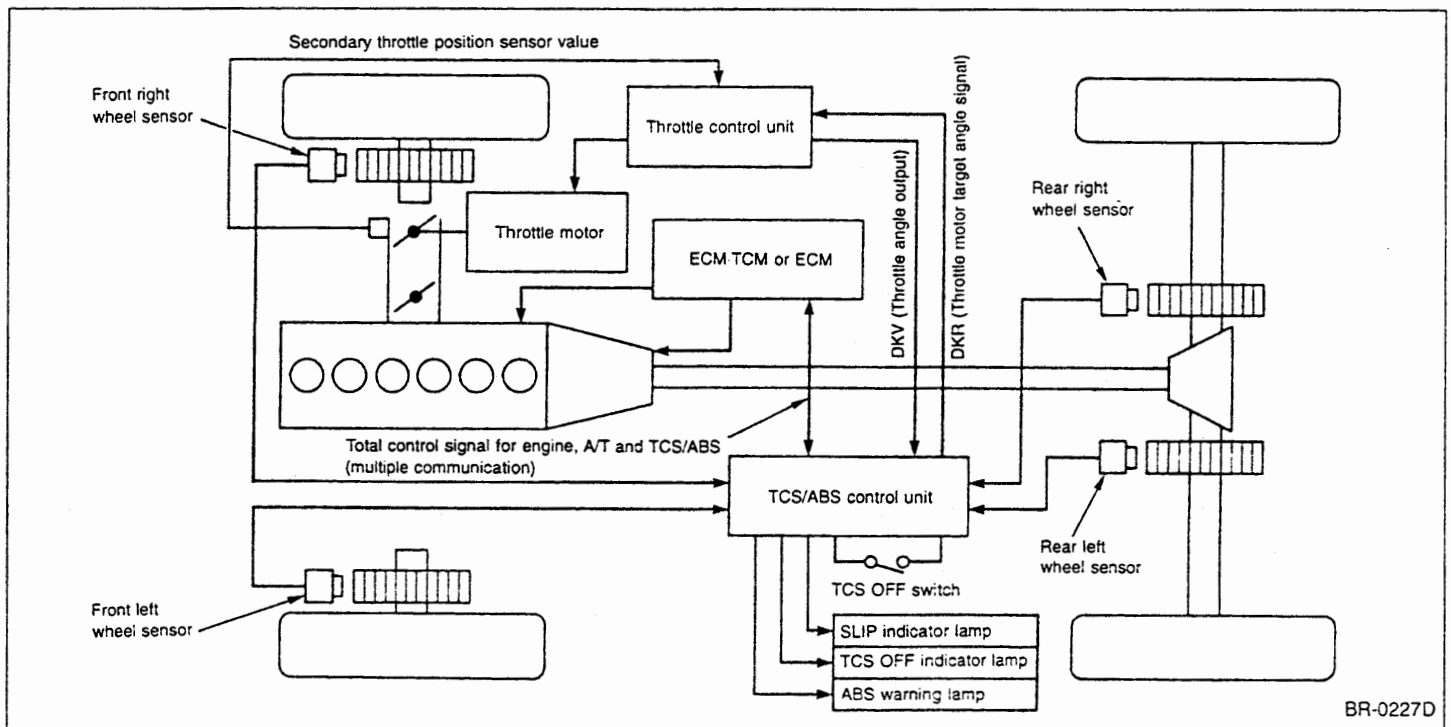

BR-0227D

# TCS/ABS SYSTEM

## Component Parts Location

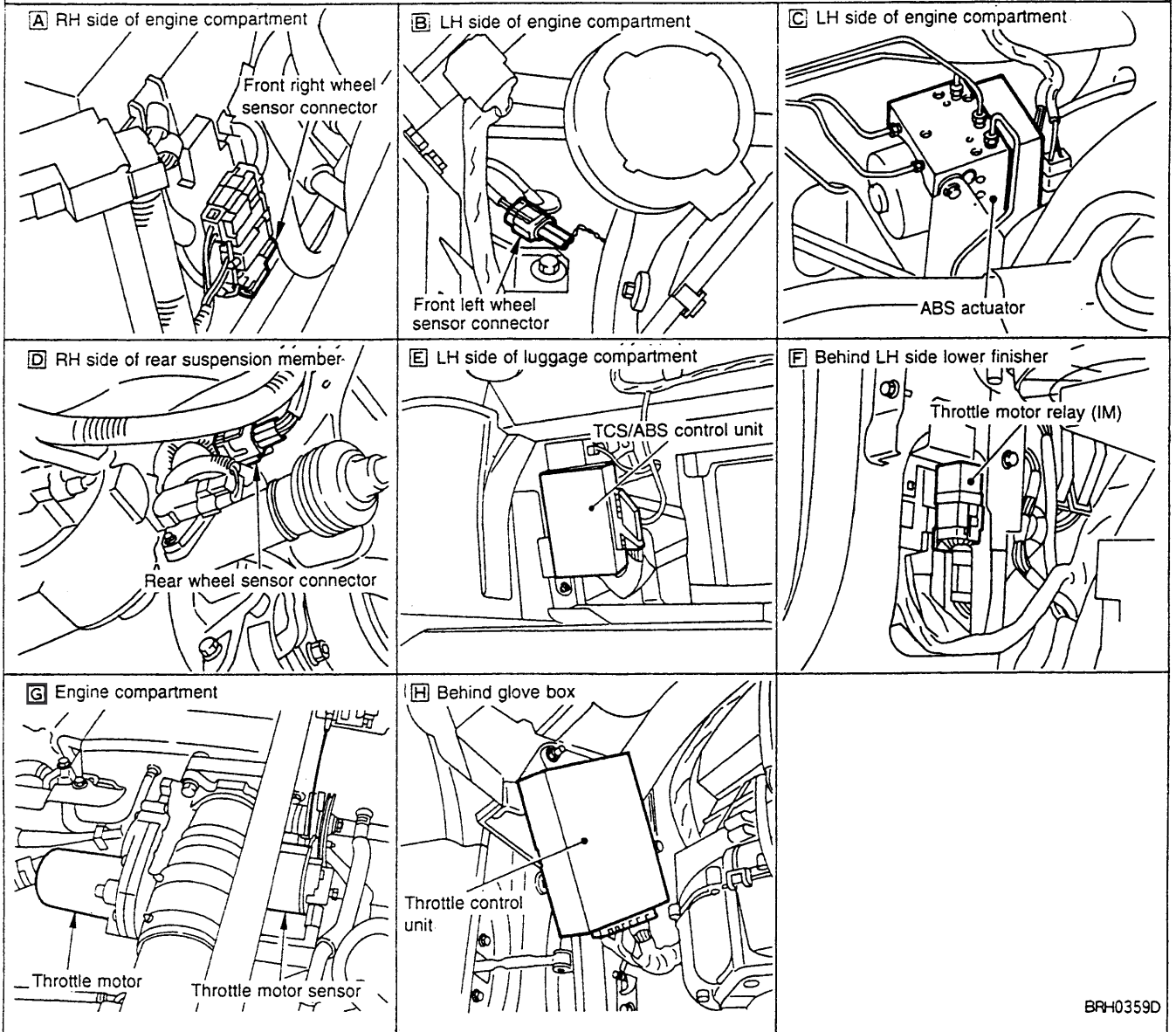
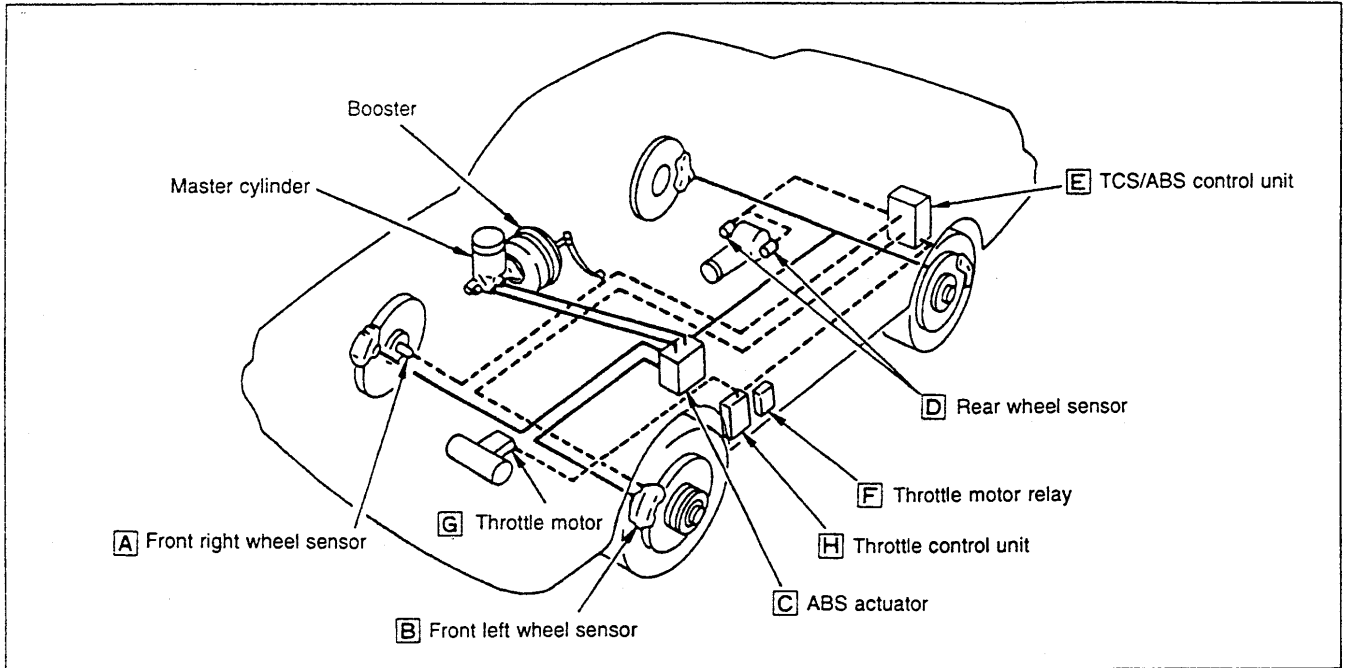

GI  
EC  
AT  
**BR**  
ST  
RS  
HA  
EL  
SD

# TCS/ABS SYSTEM

## Circuit Diagram

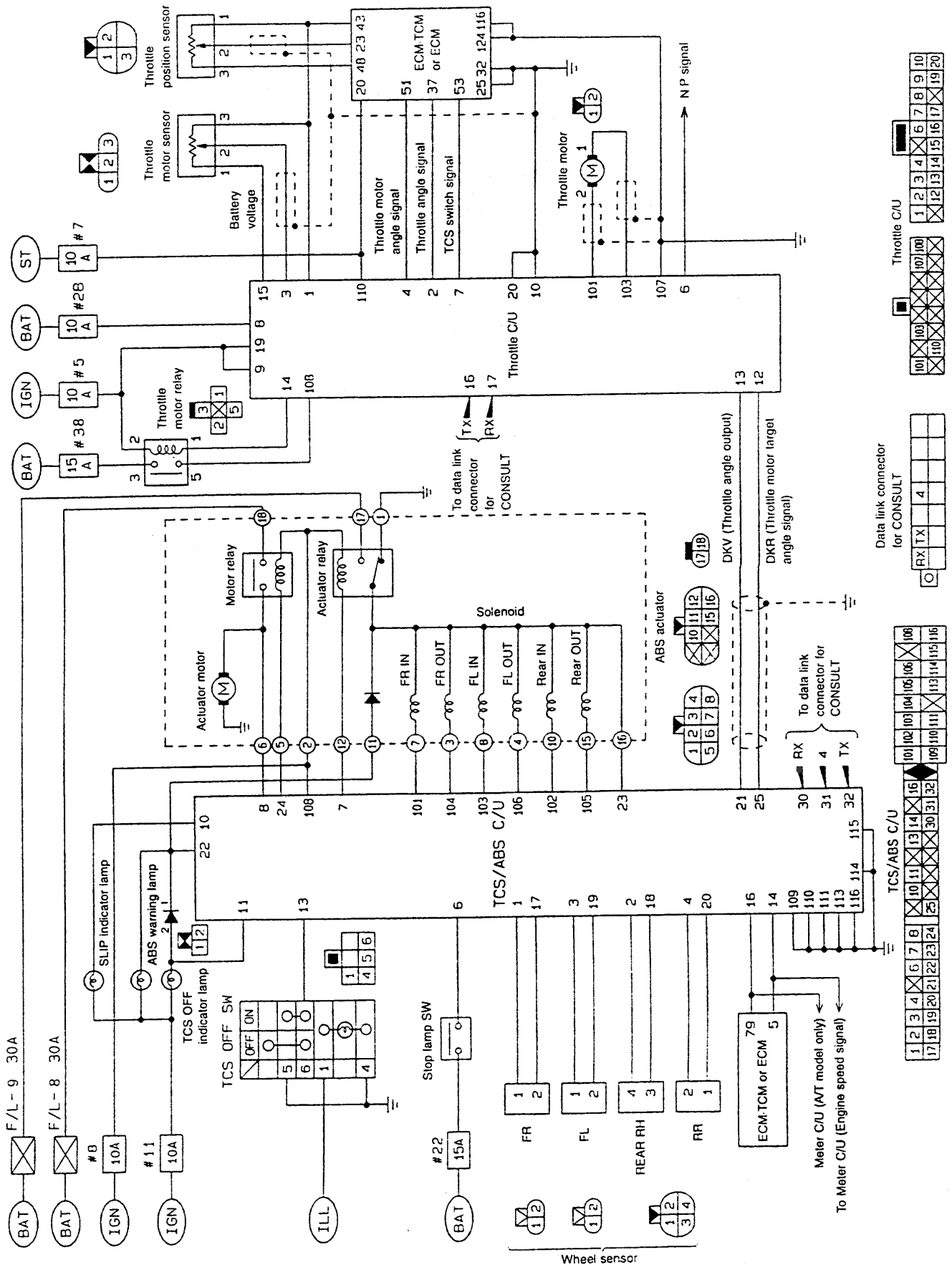

# TCS/ABS SYSTEM

## Control Unit Input/Output Signal Specifications

### USING CIRCUIT TESTER

#### TCS/ABS control unit

To perform the following inspection, the ignition switch should be turned ON with TCS/ABS control unit connector and actuator connector properly connected.

TCS/ABS control unit connector

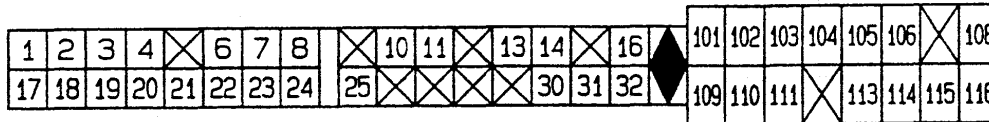

BRH0360D

Terminal No.		Item	Specifications*1	Check item (Reference)
+	-			
1	17	Front right wheel sensor	Wheels are turning (Approx. 30 km/h)*3: Pulse generates. Front: Approx. 200 Hz Rear: Approx. 200 Hz	Wheel sensors and circuit
2	18	Rear right wheel sensor		
3	19	Front left wheel sensor		
4	20	Rear left wheel sensor		
6		Stop lamp signal	Brake pedal is depressed: Battery voltage (Approx. 12V) Brake pedal is not depressed: Less than approx. 2V	Stop lamp switch and circuit
7		Actuator relay	Actuator relay is activated (with engine running): Less than approx. 2V Actuator relay is not activated (with fail-safe function activated and engine not running): Battery voltage (Approx. 12V)	ABS actuator relay and circuit
8		ABS motor monitor	ABS motor is running (in CONSULT active test mode): Battery voltage (Approx. 12V) ABS motor is stopped (with ignition switch ON): Approx. 0V	ABS motor monitor circuit
10		SLIP indicator lamp	SLIP indicator lamp ON*5: 0V SLIP indicator lamp OFF*5: Battery voltage (Approx. 12V)	SLIP indicator lamp and circuit
11		TCS OFF indicator lamp	TCS OFF indicator lamp ON*4: 0V TCS OFF indicator lamp OFF*4: Battery voltage (Approx. 12V)	TCS OFF indicator lamp and circuit
13		TCS OFF switch signal	TCS OFF switch is pressed: Approx. 0V TCS OFF switch is not pressed: Approx. 4 - 5V	TCS OFF switch and circuit
14		Engine speed signal	Pulse generates. Refer to EC section ("ECM:TCM Input/Output Reference Value")	Engine speed signal circuit
16		Total control signal (Multiple communication) for engine, A/T and TCS/ABS	<p>Approx. 5V</p> <p>0V</p> <p>0.7ms</p> <p>2ms</p> <p>BRH0326D</p>	Circuit for total control signal (Multiple communication) for engine, A/T and TCS/ABS

# TCS/ABS SYSTEM

## Control Unit Input/Output Signal Specifications (Cont'd)

Terminal No.		Item	Specifications*1	Check item (Reference)
+	-			
21		DKV (throttle angle output)	<p style="text-align: center;">BRH0325D Acceleration pedal is released: approx. 1 ms (reference)</p>	Communication line circuit between TCS/ABS control unit and throttle control unit
22		ABS warning lamp	ABS warning lamp ON*2: Approx. 0V ABS warning lamp OFF*2: Battery voltage (Approx. 12V)	ABS warning lamp and circuit
23		Actuator relay monitor	Actuator relay is activated (with engine running): Battery voltage (Approx. 12V) Actuator relay is not activated (with fail-safe function activated and engine not running): Approx. 0V	ABS warning lamp and circuit, ABS actuator relay and circuit
24		ABS motor relay	ABS motor is running (in CONSULT active test mode): Less than approx. 2V ABS motor is stopped: Battery voltage (Approx. 12V)	ABS motor, motor relay and circuit
25	Body ground	DKR (throttle motor target angle signal)	<p style="text-align: center;">BRH0325D Approx. 9 ms (Reference)</p>	Communication line circuit between TCS/ABS control unit and throttle control unit
101		Front right inlet solenoid	Actuator is activated (in CONSULT active test mode), or actuator relay is not activated (with fail-safe function activated and engine not running): Approx. 0V Actuator is not activated and actuator relay is activated (with vehicle stopped and engine running): Battery voltage (Approx. 12V)	ABS solenoid and circuit
104		Front right outlet solenoid		
102		Rear inlet solenoid		
105		Rear outlet solenoid		
103		Front left inlet solenoid		
106		Front left outlet solenoid		
108		Battery		

\*1: Do not force to open a connector terminal when using a circuit tester for inspection.

\*2: ABS warning lamp ON: When the ignition switch is turned ON (before starting the engine) or a malfunction is detected  
 ABS warning lamp OFF: When the engine has started (with the system in normal condition)

\*3: Tire pressure must be in accordance with specification.

\*4: TCS OFF indicator lamp ON: When the ignition switch is turned ON (before starting the engine), a malfunction is detected, or TCS OFF switch is turned ON  
 TCS OFF indicator lamp OFF: When the engine has started (with the system in normal condition) and the TCS OFF switch is off

\*5: SLIP indicator lamp ON: When the ignition switch is turned ON (before starting the engine) or a malfunction is detected  
 SLIP indicator lamp OFF: When the engine has started (with the system in normal condition) and the TCS is inoperative

# TCS/ABS SYSTEM

## Control Unit Input/Output Signal Specifications (Cont'd)

### Throttle control unit

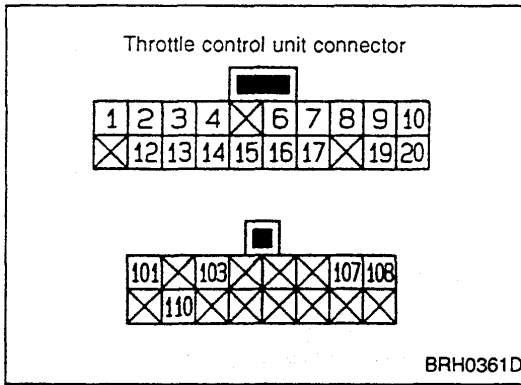

Terminal No.		Item	Specifications*	Check item (Reference)
+	-			
2		Throttle angle signal	Ignition switch ON Throttle valve is fully closed: Approx. 0.5V Throttle valve is fully open: Approx. 4.2V	Throttle position sensor circuit and ECM
3		Throttle motor sensor	Engine is idling: Approx. 4.4V	Throttle motor sensor and circuit
4		Throttle motor angle signal	Engine is idling: Approx. 3.4V	Throttle motor angle signal and circuit
7		TCS switch signal	Ignition switch ON: Approx. 5V	TCS switch signal circuit
8	Body ground	Throttle control unit power supply	Ignition switch ON: Battery voltage (Approx. 12V)	Throttle control unit power circuit
9		Throttle control unit power supply	Ignition switch ON: Battery voltage (Approx. 12V)	Throttle control unit power circuit
14		Throttle motor relay	Ignition switch ON: Approx. 0V	Throttle motor relay and circuit
15		Sensor battery voltage	Ignition switch ON: Approx. 5V	Throttle position sensor power circuit
19		Throttle control unit power supply	Ignition switch ON: Battery voltage (Approx. 12V)	Throttle control unit power circuit
108		Throttle motor relay	Ignition switch ON: Battery voltage (Approx. 12V)	Throttle motor relay and circuit
110		Start signal	Ignition switch START (Disconnect ECM-TCM connector or ECM connector.): Approx. 10V	Start signal circuit and ECM

\*: Do not force to open a connector terminal when using a circuit tester for inspection.

GI

EC

AT

BR

ST

RS

HA

EL

SD

# TCS/ABS SYSTEM

## Control Unit Input/Output Signal Specifications (Cont'd)

### USING CONSULT

Indicated are the control unit computed data. If the output circuit (harness) should be open or short-circuited, correct values may be displayed.

### TCS/ABS control unit

Display	Monitor item	Data monitor		Check item (Reference)
		Condition	Specifications	
REVOLUTION SENSOR [km/h]	Wheel speed*1	Vehicle is stationary.	0 km/h	Wheel sensor circuit
		Vehicle is driven.*1	Virtually the same speed as speedometer (within $\pm 10\%$ )	
STOP LAMP SW [ON-OFF]	Brake pedal status	Brake pedal is depressed.	ON	Stop lamp switch circuit
		Brake pedal is not depressed.	OFF	
ENG RPM SIGNAL [STOP-RUN]	Engine operation	Engine is stopped.	STOP	Engine speed signal circuit
		Engine is running at more than 400 rpm.	RUN	
IN ABS SOLENOID [ON-OFF]	Solenoid status	Actuator (solenoid) is activated (at CONSULT active test), or actuator relay is not activated (with fail-safe function activated and engine not running).	ON	Solenoid circuit
OUT ABS SOLENOID [ON-OFF]		Actuator (solenoid) is not activated and actuator relay is activated (with vehicle stopped and engine running).	OFF	
ABS ACTUATOR RELAY [ON-OFF]	Actuator relay status	Actuator relay is activated (with engine running).	ON	Actuator relay and circuit
		Actuator relay is not activated (with fail-safe function activated and engine not running).	OFF	
ABS MOTOR RELAY [ON-OFF]	Motor relay and motor status	Motor relay and motor are activated (at CONSULT active test).	ON	ABS motor, motor relay and circuit
		Motor relay and motor are not activated.	OFF	
WARNING LAMP [ON-OFF]	ABS warning lamp status*2	Warning lamp ON	ON	ABS warning lamp circuit
		Warning lamp OFF	OFF	
BATTERY BOLT [V]	Power supply voltage provided for control unit	Ignition switch ON	10 - 16V	Control unit power supply circuit and ground circuit
THRTL OPENING [%]	Throttle angle condition (linked with acceleration pedal)	Acceleration pedal is not depressed. (Ignition switch ON)	0%	Communication line circuit between TCS/ABS control unit and throttle control unit
		Acceleration pedal is depressed. (Ignition switch ON)	0 - 100%	

# TCS/ABS SYSTEM

## Control Unit Input/Output Signal Specifications (Cont'd)

Display	Monitor item	Data monitor		Check item (Reference)
		Condition	Specifications	
THRTL OPENING TARGET [%]	Motor throttle angle condition	TCS is inoperative.	0%	Communication line circuit between TCS/ABS control unit and throttle control unit
		TCS is operational.	0 - 100%	
TCS MODE*3	Number of cylinders to which fuel is cut off	TCS is inoperative.	0	Communication line circuit between TCS/ABS control unit and ECM-TCM or ECM
		TCS is operational.	0 - 24	
GEAR	Gear selection	1: 1st gear 2: 2nd gear 3: 3rd gear 4: 4th gear 5: 5th gear		
TCS SW	TCS OFF switch status (ON/OFF)	TCS switch ON	ON	TCS OFF switch circuit
		TCS switch OFF	OFF	
TCS OFF LAMP	TCS OFF indicator lamp status	TCS OFF indicator lamp ON	ON	TCS OFF indicator lamp circuit
		TCS OFF indicator lamp OFF	OFF	
SLIP LAMP	SLIP indicator lamp status	SLIP indicator lamp is ON.	ON	SLIP indicator lamp circuit
		SLIP indicator lamp is OFF.	OFF	
P/N POSITION SIGNAL	PNP switch signal or neutral position switch signal status (ON/OFF)	A/T selector position: N or P M/T shift position: Neutral	ON	A/T PNP switch or neutral position switch circuit
		A/T selector position: Other than N and P M/T shift position: Other than Neutral	OFF	

\*1: Tire pressure must be in accordance with specification.

\*2: ABS warning lamp ON: When the ignition switch is turned ON (before starting the engine) or a malfunction is detected  
ABS warning lamp OFF: When the engine has started (with the system in normal condition)

\*3: TCS mode: 0 - 24, number of cylinders to which fuel is cut off × 4

### Throttle control unit

Display	Monitor item	Data monitor		Check item (Reference)
		Condition	Specifications	
THRTL POS SEN	Sensor voltage (V)	Throttle valve is fully closed.	Approx. 0.5V	Throttle position sensor circuit
TH MOTOR VOLT	Sensor voltage (V)	Engine is idling.	Approx. 3.4V	Throttle motor sensor circuit
TH OPEN CONT	Motor throttle target angle signal (ms)	TCS is inoperative	Approx. 9 ms	Communication line circuit between TCS/ABS control unit and throttle control unit
START SIGNAL	ON/OFF	Ignition switch ON	ON	Start signal circuit
NEUT POSI SW	ON/OFF	Shift (selector) lever is in park/neutral position.	ON	Park/neutral position switch circuit



## Precautions for Trouble Diagnosis

- After performing trouble diagnosis, be sure to erase trouble stored in memory. Refer to "CONSULT for TCS/ABS Control Unit Control System" (BR-27), "Self-diagnosis for TCS/ABS Control Unit Control System" (BR-34), "CONSULT for Throttle Control Unit Control System" (BR-37) or "Self-diagnosis for Throttle Control Unit Control System" (BR-41).
- The concerns that are difficult to duplicate may be caused by faulty electrical connections. Move harnesses or harness connectors by hand to check if there is any poor mating of connector halves or faulty connection.
- Do not force to open a connector terminal when using a circuit tester for inspection.
- Read GI section thoroughly in advance and make sure of all the general precautions.

## Basic Inspection

### BASIC INSPECTION 1 — Brake fluid level and leakage

1. Check brake fluid level in reservoir tank. Replenish brake fluid if necessary.
2. Check for leakage at or around brake piping and ABS actuator. If leakage or seepage is noted, proceed as follows:
  - If ABS actuator connectors are loose, tighten to specified torque. Recheck to ensure that leakage is no longer present.
  - If flare nut threads at piping connectors or actuator threads are damaged, replace faulty parts with new ones. Recheck to ensure that leakage is no longer present.
  - If brake fluid leaks through areas other than actuator connectors, wipe off using a clean cloth. Recheck for leakage or seepage. If necessary, replace faulty parts with new ones.
  - If brake fluid leaks at or seeps through ABS actuator, wipe off using a clean cloth. Recheck for leakage or seepage. If necessary, replace ABS actuator with new one.

#### CAUTION:

**ABS actuator cannot be disassembled. Do not attempt to disassemble it.**

3. Check brake disc rotors and pads for proper operation.

### BASIC INSPECTION 2 — Loose power line terminal

Check battery terminals (positive and negative) and battery mounting (ground) for looseness. If necessary, tighten to specified torque. Check the battery for lower voltage.

### BASIC INSPECTION 3 — SLIP indicator lamp, TCS OFF indicator lamp and ABS warning lamp

1. Turn ignition switch "ON" to ensure that TCS OFF indicator lamp lights up. If TCS OFF indicator lamp does not light, check TCS OFF indicator lamp circuit.
2. Turn ignition switch "ON" to ensure that SLIP indicator lamp lights up. If SLIP indicator lamp does not light, check SLIP indicator lamp circuit.
3. Turn ignition switch "ON" to ensure that ABS warning lamp lights up. If ABS warning lamp does not light, check ABS warning lamp circuit.
4. Check that the SLIP indicator lamp and the ABS warning lamp go off approx. 1 second after the engine has started. If either of the lamps still remains on, perform the self-diagnosis for TCS/ABS control unit control system and the self-diagnosis for throttle control unit control system.
5. After driving vehicle at approx. 30 km/h for approx. 1 minute, check to ensure that the SLIP indicator lamp and the ABS warning lamp are off. If either of the lamps still remains on, perform the self-diagnosis for TCS/ABS control unit control system and the self-diagnosis for throttle control unit control system.
6. Check that the TCS OFF indicator lamp turns ON and OFF when the TCS OFF switch is turned to ON and OFF respectively, with the engine running. If the lamp status does not correspond to the switch position, check the TCS OFF switch circuit.
7. Check that the TCS OFF indicator lamp goes off when the engine has started with the TCS OFF switch OFF. If the TCS OFF indicator lamp does not go off even 10 seconds after the engine has started, perform the self-diagnosis for TCS/ABS control unit control system and the self-diagnosis for throttle control unit control system.
8. After driving vehicle at approx. 30 km/h for approx. 1 minute with the TCS OFF switch OFF, check to ensure that the TCS OFF indicator lamp is off. If the TCS OFF indicator lamp lights up, perform the self-diagnosis for TCS/ABS control unit control system and the self-diagnosis for throttle control unit control system.
9. After performing self-diagnosis procedures, be sure to erase trouble stored in memory.

## CONSULT for TCS/ABS Control Unit Control System

### CONTROL UNIT PART NUMBER

The part number that is shown on the control unit label and CONSULT

A/T model: 47850 AA310

M/T model: 47850 AA110

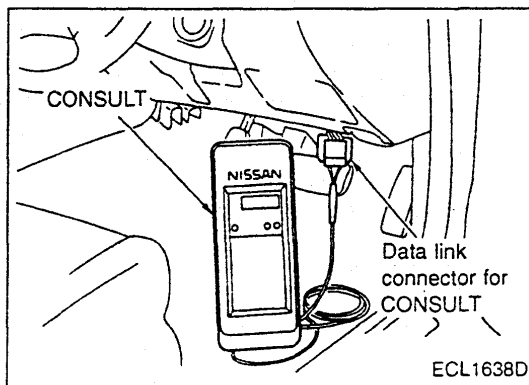

### SELF-DIAGNOSIS PROCEDURE

1. Collect information on the concern from the customer, and then perform basic inspections.
2. Turn ignition switch OFF and connect CONSULT connector to data link connector for CONSULT on the vehicle.
3. Start engine and drive vehicle at approx. 30 km/h for approx. 1 minute.
4. Stop vehicle with engine running and touch "START", "ABS" and "SELF-DIAG RESULTS" sequentially on the CONSULT screen.
  - If "START" is touched immediately after engine is started or ignition switch is turned on, "ABS" may not be displayed on "SELECT SYSTEM" screen. To display "ABS", repeat the self-diagnosis procedure from the beginning.
5. Self-diagnosis results are displayed on the screen. (Touch "PRINT" to print out the self-diagnosis results, if necessary.)
  - If "NO FAIL" is displayed, inspect the SLIP indicator lamp, the TCS OFF indicator lamp and the ABS warning lamp. Refer to the previous page.
6. Perform appropriate inspection from the self-diagnostic results mode and repair or replace faulty parts.
7. Start engine and drive vehicle at approx. 30 km/h for approx. 1 minute.
  - **Recheck to ensure that there is no other malfunction.**
8. Turn ignition switch OFF to prepare for erasing the trouble stored in memory.
9. Start engine and touch "START", "ABS", "SELF-DIAG RESULTS" and "ERASE" sequentially on the CONSULT screen to erase the trouble stored in memory.
  - **If the trouble stored in memory is not erased, repeat step 6.**
10. Drive vehicle at approx. 30 km/h for approx. 1 minute and then confirm that the TCS OFF indicator lamp, the SLIP indicator lamp, and the ABS warning lamp are OFF.
  - **TCS OFF switch is not in cancel condition.**

## TCS/ABS SYSTEM

### CONSULT for TCS/ABS Control Unit Control System (Cont'd)

#### SELF-DIAGNOSTIC RESULTS MODE

Diagnostic item	Diagnostic item is detected when...	Check item
FR RH SENSOR [OPEN]	Circuit for front right wheel sensor is open. Or an abnormally high input voltage is entered due to short to battery.	Wheel sensor circuit
FR LH SENSOR [OPEN]	Circuit for front left wheel sensor is open. Or an abnormally high input voltage is entered due to short to battery.	
REAR SENSOR [OPEN]	Circuit for rear right wheel sensor is open. Or an abnormally high input voltage is entered due to short to battery.	
RR LH SENSOR [OPEN]	Circuit for rear left wheel sensor is open. Or an abnormally high input voltage is entered due to short to battery.	
FR RH SENSOR [SHORT]	Front right wheel sensor is short-circuited or shorted to ground, or gap between the wheel sensor and the sensor rotor is large. An abnormally low input voltage is entered and input signal is abnormal.	
FR LH SENSOR [SHORT]	Front left wheel sensor is short-circuited or shorted to ground, or gap between the wheel sensor and the sensor rotor is large. An abnormally low input voltage is entered and input signal is abnormal.	
RR RH SENSOR [SHORT]	Rear right wheel sensor is short-circuited or shorted to ground, or gap between the wheel sensor and the sensor rotor is large. An abnormally low input voltage is entered and input signal is abnormal.	
RR LH SENSOR [SHORT]	Rear left wheel sensor is short-circuited or shorted to ground, or gap between the wheel sensor and the sensor rotor is large. An abnormally low input voltage is entered and input signal is abnormal.	
FR RH IN ABS SOL [OPEN]	Circuit for front right inlet ABS solenoid valve is open, or an output voltage is much lower than the specified value due to short to ground.	Solenoid and circuit
FR LH IN ABS SOL [OPEN]	Circuit for front left inlet ABS solenoid valve is open, or an output voltage is much lower than the specified value due to short to ground.	
REAR IN ABS SOL [OPEN]	Circuit for rear inlet ABS solenoid valve is open, or an output voltage is much lower than the specified value due to short to ground.	
FR RH IN ABS SOL [SHORT]	Circuit for front right inlet ABS solenoid valve is shorted, or an output voltage is much higher than the specified value due to short to battery.	
FR LH IN ABS SOL [SHORT]	Circuit for front left inlet ABS solenoid valve is shorted, or an output voltage is much higher than the specified value due to short to battery.	
REAR IN ABS SOL [SHORT]	Circuit for rear inlet ABS solenoid valve is shorted, or an output voltage is much higher than the specified value due to short to battery.	
FR RH OUT ABS SOL [OPEN]	Circuit for front right outlet ABS solenoid valve is open, or an output voltage is much lower than the specified value due to short to ground.	
FR LH OUT ABS SOL [OPEN]	Circuit for front left outlet ABS solenoid valve is open, or an output voltage is much lower than the specified value due to short to ground.	
REAR OUT ABS SOL [OPEN]	Circuit for rear outlet ABS solenoid valve is open, or an output voltage is much lower than the specified value due to short to ground.	
FR RH OUT ABS SOL [SHORT]	Circuit for front right outlet ABS solenoid valve is shorted, or an output voltage is much higher than the specified value due to short to battery.	
FR LH OUT ABS SOL [SHORT]	Circuit for front left outlet ABS solenoid valve is shorted, or an output voltage is much higher than the specified value due to short to battery.	
REAR OUT ABS SOL [SHORT]	Circuit for rear outlet ABS solenoid valve is shorted, or an output voltage is much higher than the specified value due to short to battery.	
ABS MOTOR [ON FAILURE]	ABS motor turns ON when control unit sends OFF signal. ABS motor circuit is open or shorted to ground.	ABS motor, motor relay and circuit
ABS MOTOR [OFF FAILURE]	ABS motor turns OFF when control unit sends ON signal. Relay control wire is broken.	

# TCS/ABS SYSTEM

## CONSULT for TCS/ABS Control Unit Control System (Cont'd)

Diagnostic item	Diagnostic item is detected when...	Check item
ABS ACTUATOR RELAY [ON FAILURE]	ABS actuator relay turns ON when control unit sends OFF signal. Actuator relay is short-circuited to ground.	ABS actuator relay and circuit
ABS ACTUATOR RELAY [OFF FAILURE]	ABS actuator relay turns OFF when control unit sends ON signal. Relay control wire is broken.	
BATTERY VOLTAGE [VB-HIGH]	TCS/ABS control unit battery voltage is abnormally high.	TCS/ABS control unit power supply and ground circuit
BATTERY VOLTAGE [VB-LOW]	TCS/ABS control unit battery voltage is abnormally low.	
CONTROL UNIT	Function of calculation in TCS/ABS control unit has failed.	TCS/ABS control unit
ABS MOTOR [LOCK FAILURE]	ABS motor speed is abnormally low.	ABS motor, motor relay and circuit
ENGINE SPEED SIG	<ul style="list-style-type: none"> <li>● Engine speed signal is interrupted or signal wire is suspected to be broken.</li> <li>● TCS/ABS control unit connector or ECM-TCM or ECM connector is poorly connected.</li> </ul>	Engine speed signal circuit
THROTTLE POSI SIG	<ul style="list-style-type: none"> <li>● The communication line between TCS/ABS control unit and throttle control unit is open or shorted.</li> <li>● Throttle control system (throttle control unit, peripheral harness, and throttle actuator) is abnormal.</li> <li>● TCS/ABS control unit or throttle control unit battery voltage is low.</li> </ul>	Circuit for the communication line between TCS/ABS control unit and throttle control unit
ENGINE SYSTEM	Engine main components (crankshaft position sensor, mass air flow sensor, engine coolant temperature sensor, ignition primary signal, throttle position sensor, and motor throttle position sensor) are abnormal.	Engine system
LAN SIGNAL 1	<ul style="list-style-type: none"> <li>● Total control signal (multiple signal) for engine, A/T and TCS/ABS is abnormal (open or shorted communication harness, faulty connections, abnormal TCS/ABS control unit or ECM-TCM or ECM).</li> <li>● TCS/ABS control unit power is momentarily cut off or decreased.</li> </ul>	Total control signal 1 (multiple signal) for engine, A/T and TCS/ABS
LAN SIGNAL 2	<ul style="list-style-type: none"> <li>● Total control signal (multiple signal) for engine, A/T and TCS/ABS is abnormal (open or shorted communication harness, faulty connections, abnormal TCS/ABS control unit or ECM-TCM or ECM).</li> <li>● ECM-TCM or ECM starter switch is stuck to ON.</li> <li>● The starter switch is ON for 10 seconds or longer even after the engine has started. (This is not a malfunction.)</li> <li>● ECM-TCM or ECM is abnormal. (Total control signal (multiple signal) for engine, A/T and TCS/ABS is malfunctioning. Or the system is in the process of CPU back up.)</li> </ul>	Total control signal 2 (multiple signal) for engine, A/T and TCS/ABS
LAN SIGNAL 3	TCS/ABS is abnormal.	—

# TCS/ABS SYSTEM

## CONSULT for TCS/ABS Control Unit Control System (Cont'd)

Diagnostic item	Diagnostic item is detected when...	Check item
LAN CIRCUIT 1	<ul style="list-style-type: none"><li>● Total control signal (multiple signal) for engine, A/T and TCS/ABS is abnormal (open or shorted communication harness, faulty connections, abnormal TCS/ABS control unit or ECM-TCM or ECM).</li><li>● ECM-TCM or ECM power is cut off or decreased for 2 seconds or longer.</li></ul>	Total control signal 1, 2 (multiple signal) for engine, A/T and TCS/ABS
LAN CIRCUIT 2	<ul style="list-style-type: none"><li>● Total control signal (multiple signal) for engine, A/T and TCS/ABS is suspected to be interrupted (open or shorted communication harness, faulty connections, abnormal TCS/ABS control unit or ECM-TCM or ECM).</li><li>● ECM-TCM or ECM power is cut off or decreased for 2 seconds or longer.</li></ul>	

### NOTE:

- If "NO FAIL" is displayed as a result of the CONSULT self-diagnosis when the ABS warning lamp is lit, inspect the engine speed signal circuit.
- If "ABS" is not displayed on "SELECT SYSTEM" screen, check ABS control unit and data link connector circuit, and make sure of the CONSULT card number.
- If "ENGINE SYSTEM", "LAN SIGNAL 1", "LAN SIGNAL 2", "LAN SIGNAL 3", "LAN CIRCUIT 1" or "LAN CIRCUIT 2" is displayed on the screen, perform the self-diagnosis for the ECM-TCM or ECM.
- If "THROTTLE CONTROLLER COMMUNICATION" is displayed on the screen, perform the self-diagnosis for throttle control unit.

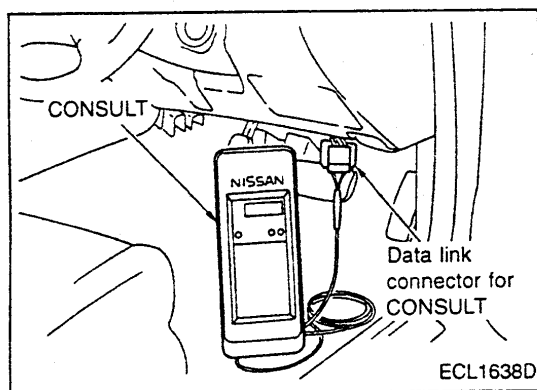

### DATA MONITOR PROCEDURE

- Refer to CONSULT Instruction Manual for details on data monitor function.
1. Turn ignition switch OFF.
  2. Connect CONSULT connector to data link connector for CONSULT.
  3. Turn ignition switch ON.
  4. Touch "START" on CONSULT screen.
  5. Touch "ABS" on CONSULT screen.
- If "START" is touched immediately after engine is started or ignition switch is turned ON, "ABS" may not be displayed on "SELECT SYSTEM" screen. To display "ABS", repeat the data monitor procedure from the beginning.
6. Touch "DATA MONITOR".
  7. Touch "SETTING" to set recording condition.
  8. Touch "AUTO TRIG", "LONG TIME" and then "ENTER".
  9. Return to "SELECT MONITOR ITEM" screen and touch "C/U INPUT ITEM", "ALL SIGNALS" or "SELECTION FROM MENU". Refer to "DATA MONITOR MODE" on the next page.
  10. Touch "START".
  11. Display data monitor.
  12. If necessary, sequentially touch "REC START", "REC STOP", "DATA DISPLAY", "NUMBER PRINT" and "PRINT" to print out the data.

# TCS/ABS SYSTEM

## CONSULT for TCS/ABS Control Unit Control System (Cont'd)

### DATA MONITOR MODE

Display	Select monitor item			Remarks
	ECM input signals	All signals	Selection from menu	
FR RH SEN [km/h]	○	○	○	Displays vehicle speed computed based on front right wheel sensor signal.
FR LH SEN [km/h]	○	○	○	Displays vehicle speed computed based on front left wheel sensor signal.
REAR SEN [km/h]	○	○	○	Displays vehicle speed computed based on rear right wheel sensor signal.
RR LH SEN [km/h]	○	○	○	Displays vehicle speed computed based on rear left wheel sensor signal.
F/R IN SOL [ON-OFF]	—	○	○	Indicates operating condition (ON/OFF) for front right inlet solenoid.
F/R OUT SOL [ON-OFF]	—	○	○	Indicates operating condition (ON/OFF) for front right outlet solenoid.
F/L IN SOL [ON-OFF]	—	○	○	Indicates operating condition (ON/OFF) for front left inlet solenoid.
F/L OUT SOL [ON-OFF]	—	○	○	Indicates operating condition (ON/OFF) for front left outlet solenoid.
REAR IN SOL [ON-OFF]	—	○	○	Indicates operating condition (ON/OFF) for rear inlet solenoid.
RR OUT SOL [ON-OFF]	—	○	○	Indicates operating condition (ON/OFF) for rear outlet solenoid.
ABS ACTUATOR [ON-OFF]	—	○	○	Indicates ABS actuator relay status (ON/OFF).
ABS MOTOR [ON-OFF]	—	○	○	Indicates ABS motor relay status (ON/OFF).
STOP LAMP SW [ON-OFF]	○	○	○	Indicates stop lamp switch status (ON/OFF).
ENG SPEED SIG [RUN/STOP]	○	○	○	Indicates engine operation.
WARNING LAMP [ON-OFF]	—	○	○	Indicates ABS warning lamp status.
BATTERY VOLT [V]	○	—	○	Indicates the voltage supplied to the TCS/ABS control unit.
THRTL OPENING [%]	○	○	○	Indicates throttle angle condition.
THL OP TARGET [%]	—	○	○	Indicates throttle control unit target angle.
TCS MODE	—	○	○	Indicates the value at which fuel to ECM is cut off.
GEAR	○	○	○	Indicates the gear position.
TCS SW [ON-OFF]*	○	○	○	Indicates TCS switch status (ON/OFF).
TCS OFF LAMP [ON-OFF]	—	○	○	Indicates TCS OFF indicator lamp status.
SLIP LAMP [ON-OFF]	—	○	○	Indicates SLIP indicator lamp status.
P/N POSI SIG [ON-OFF]	○	○	○	Indicates the selector position (ON/OFF) based on the A/T PNP switch signal or the neutral position switch signal.

\*: The TCS switch only indicates that the switch is ON or OFF. It does not necessarily correspond to the TCS operation condition (TCS OFF indicator lamp OFF or ON).

# TCS/ABS SYSTEM

## CONSULT for TCS/ABS Control Unit Control System (Cont'd)

### ACTIVE TEST PROCEDURE

- When conducting Active test, vehicle must be stationary.
  - Confirm that brakes have been bled completely.
  - When ABS warning lamp stays on, never conduct Active test.
1. Turn ignition switch OFF.
  2. Connect CONSULT to Data Link Connector for CONSULT.
  3. Start engine.
  4. Touch "START" on CONSULT screen.

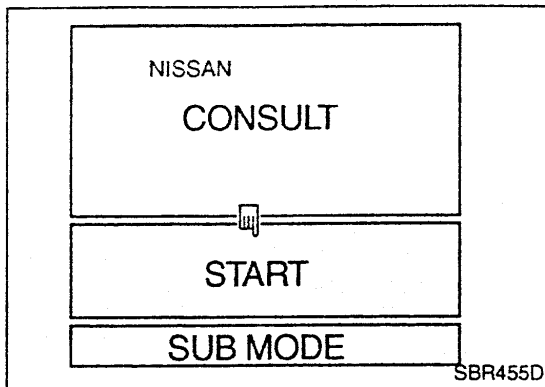

SBR455D

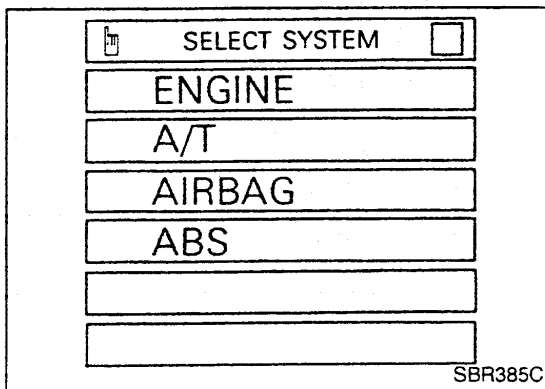

SBR385C

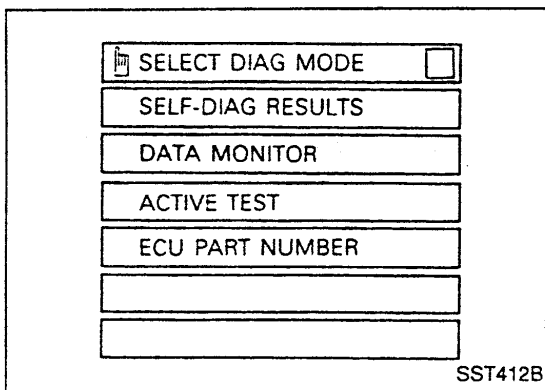

SST412B

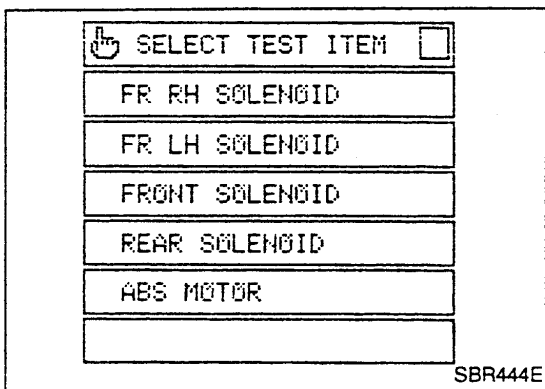

SBR444E

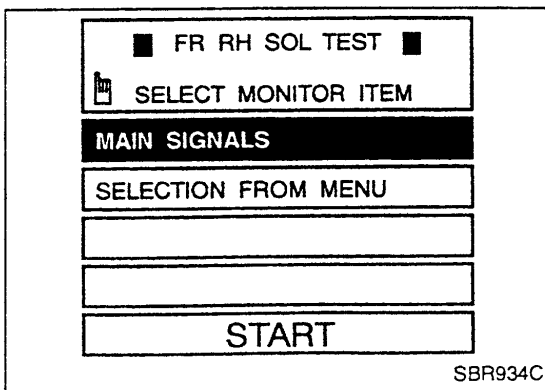

SBR934C

5. Touch "ABS".

6. Touch "ACTIVE TEST".

7. Select active test item by touching screen.

8. Touch "START".

# TCS/ABS SYSTEM

## CONSULT for TCS/ABS Control Unit Control System (Cont'd)

9. "ACTIVE TEST" screen is displayed.

### ABS solenoid valve

- To check that ABS solenoid valves (inlet and outlet) operate in the following manner, touch "UP", "KEEP" and "DOWN" on the screen while observing the monitor.

Operation	UP	KEEP	DOWN
IN ABS S/V	OFF	ON	ON
OUT ABS S/V	OFF	OFF	ON*

\*: Solenoid valve stays ON for 1 to 2 seconds after touching the key, and then turns OFF.

- If the active test is conducted with brake pedal depressed, the brake pedal travel limit may change. This is a normal condition.
- "TEST IS STOPPED" message is displayed 10 seconds after the operation is started.
- If the active test needs to be performed again after "TEST IS STOPPED" is displayed, repeat step 8.

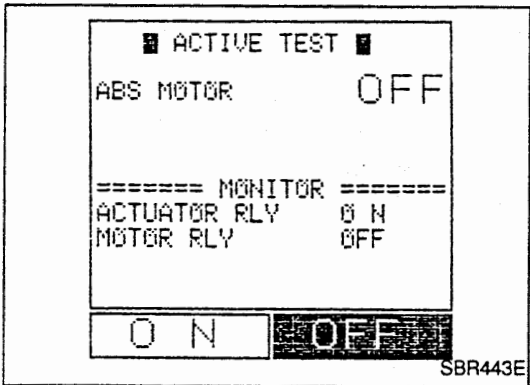
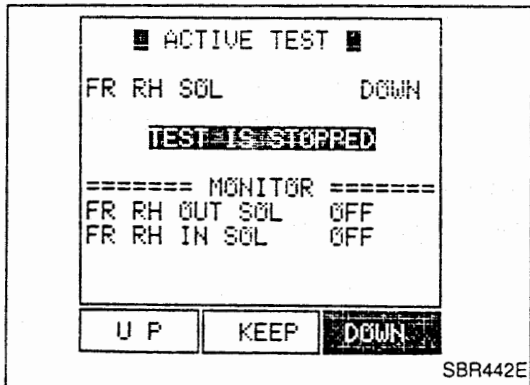
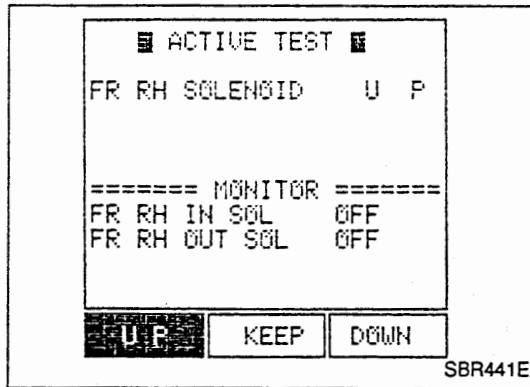

### ABS motor

- Touch "ON" and "OFF" on the screen to check that ABS motor relay and ABS actuator relay operate as follows:

Operation	ON	OFF
ABS actuator relay	ON	ON
ABS motor relay	ON	OFF

- If the active test is conducted with brake pedal depressed, the brake pedal travel limit may change. This is a normal condition.
- "TEST IS STOPPED" message is displayed 10 seconds after the operation is started.



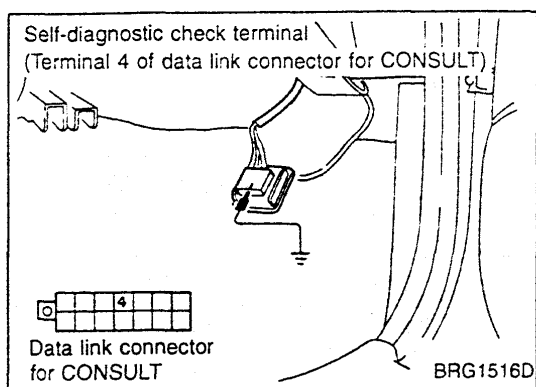

## Self-diagnosis for TCS/ABS Control Unit Control System

### SELF-DIAGNOSIS PROCEDURE

1. Collect information on the concern from the customer, and then perform basic inspections.
2. Drive vehicle at approx. 30 km/h for approx. 1 minute.
3. Stop vehicle and start diagnosis.
4. Turn ignition switch "OFF".
5. Ground the self-diagnostic check terminal 4 on the data link connector for CONSULT.
6. Turn ignition switch "ON" to start the self-diagnostic results mode.

### CAUTION:

- **Keep terminal 4 grounded during self-diagnosis. Do not depress brake pedal. Do not start engine. (Self-diagnosis would not start.)**
  - **When SLIP indicator lamp does not start blinking, check TCS/ABS control unit power supply circuit and ground circuit.**
7. The SLIP indicator lamp starts blinking to indicate the malfunction code No. 3 or 4 seconds after the self-diagnostic results mode is started.
  - **The indication terminates after 5 minutes. Turning the ignition switch from "OFF" to "ON" resumes blinking the indication.**
  - **During the SLIP indicator lamp operation shown above, TCS OFF indicator lamp and ABS warning lamp are lit.**
  8. Verify the location of the malfunction with "MALFUNCTION CODE/SYMPTOM CHART", BR-36. Then make the necessary repairs.
  9. After the malfunctions are repaired, erase the malfunction codes stored in the control unit. Refer to "HOW TO ERASE SELF-DIAGNOSTIC RESULTS" on the next page.
  10. Rerun the self-diagnostic results mode to verify that the malfunction codes have been erased.
  - **When the malfunction codes have been erased, the start code is only indicated.**
  11. Disconnect the check terminal from the ground. The self-diagnostic results mode is now complete.
  12. Drive vehicle at approx. 30 km/h for approx. 1 minute, and then check that the TCS OFF indicator lamp, the SLIP indicator lamp and the ABS warning lamp are OFF.

### HOW TO READ SELF-DIAGNOSTIC RESULTS (Malfunction codes)

- Determine the code No. by observing the time and the frequency that the SLIP indicator lamp flashes ON and OFF. Refer to the next page.
- When multiple malfunctions occur at a time, up to three code numbers can be stored; the latest malfunction will be indicated first.
- The indication begins with the start code No. 12. After that a maximum of three code numbers appear in the order of the latest one first. The indication then returns to the start code No. 12 to repeat.
- The start code No. 12 is only indicated repeatedly when there is no malfunction.

# TCS/ABS SYSTEM

## Self-diagnosis for TCS/ABS Control Unit Control System (Cont'd)

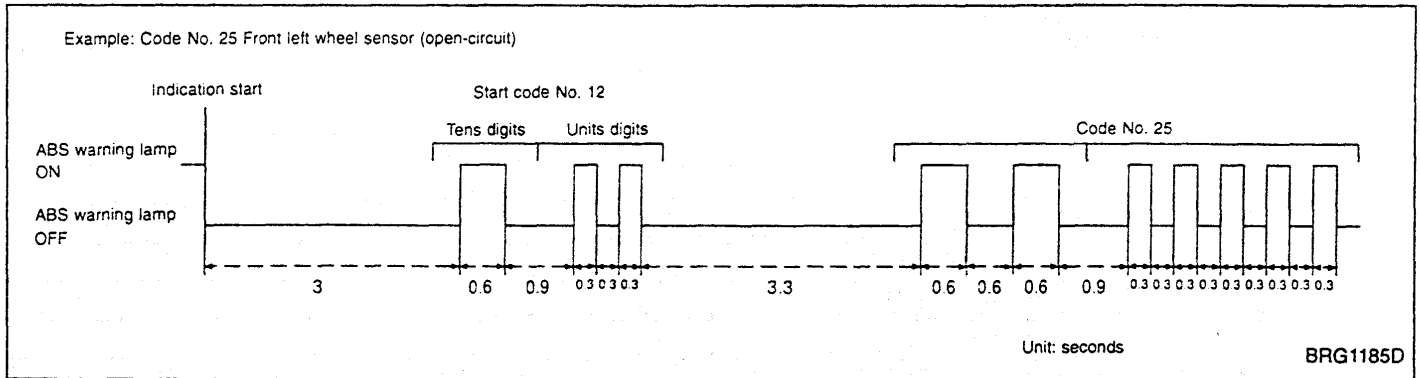

### HOW TO ERASE SELF-DIAGNOSTIC RESULTS (Malfunction codes)

1. Turn the ignition switch "ON" and start the engine.
2. Drive the vehicle at approx. 30 km/h for approx. 1 minute to check that there is no other malfunction.
3. Stop the vehicle and turn the ignition switch "OFF".
4. Ground the self-diagnostic check terminal 4 on the data link connector for CONSULT.
5. Turn the ignition switch "ON" to start the self-diagnostic results mode.

#### CAUTION:

Keep terminal 4 grounded during self-diagnosis. Do not depress the brake pedal during self-diagnosis. Do not start the engine.

6. The SLIP indicator lamp starts blinking to indicate the malfunction code No. 3 or 4 seconds after the self-diagnostic results mode is started.

- The indication terminates after 5 minutes. Turning the ignition switch from "OFF" to "ON" resumes blinking the indication. During the SLIP indicator lamp operation shown above, TCS OFF indicator lamp and ABS warning lamp are lit.

7. Under the self-diagnostic results mode, the malfunction memory erase mode starts when the check terminal is disconnected from the ground.
8. Ground the check terminal 3 times or more in succession within 12.5 seconds after the erase mode starts. (Each grounding must be 2 seconds or longer.)
9. Disconnect the grounding cable from the check terminal to erase the malfunction memory and complete the self-diagnosis.
10. Rerun the self-diagnostic results mode to verify that the malfunction codes have been erased.

- When the malfunction codes have been erased, the start code No. 12 is only indicated.

11. Disconnect the check terminal from the ground. The self-diagnostic results mode is now complete.
12. Drive vehicle at approx. 30 km/h for approx. 1 minute, and then check that the TCS OFF indicator lamp, the SLIP indicator lamp and the ABS warning lamp are OFF.
13. Turn the ignition switch "OFF".

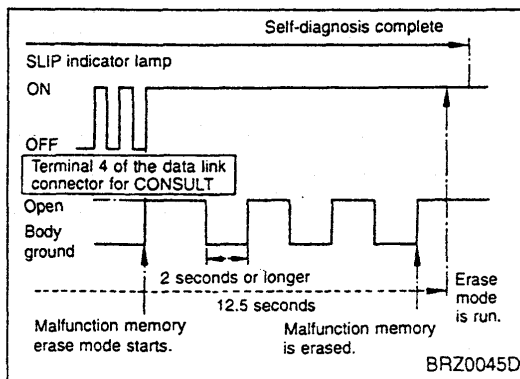

# TCS/ABS SYSTEM

## Self-diagnosis for TCS/ABS Control Unit Control System (Cont'd)

### MALFUNCTION CODE/SYMPTOM CHART

Malfunction code No.	Check item	Detection time		Lamp ON			Fail-safe operation
		Engine running	In driving	ABS	TCS OFF	SLIP	
12	Normal	—	—	—	—	—	—
21	Front right wheel sensor (open-circuit)	○	○	○	○	○	○
22	Front right wheel sensor (short-circuit)	—	○	○	○	○	○
25	Front left wheel sensor (open-circuit)	○	○	○	○	○	○
26	Front left wheel sensor (short-circuit)	—	○	○	○	○	○
31	Rear right wheel sensor (open-circuit)	○	○	○	○	○	○
32	Rear right wheel sensor (short-circuit)	—	○	○	○	○	○
35	Rear left wheel sensor (open-circuit)	○	○	○	○	○	○
36	Rear left wheel sensor (short-circuit)	—	○	○	○	○	○
41	Front right outlet solenoid valve and circuit	○	○	○	○	○	○
42	Front right inlet solenoid valve and circuit	○	○	○	○	○	○
45	Front left outlet solenoid valve and circuit	○	○	○	○	○	○
46	Front left inlet solenoid valve and circuit	○	○	○	○	○	○
55	Rear outlet solenoid valve and circuit	○	○	○	○	○	○
56	Rear right inlet solenoid valve and circuit	○	○	○	○	○	○
57	Battery voltage (low)	○	○	○	○	○	—*1
58	Throttle control unit system or circuit for the communication line between TCS/ABS control unit and throttle control unit	○	○	—*2	○	○	○
61	Actuator motor and motor relay circuit	○	○	○	○	○	○
63	Actuator relay circuit	○	○	○	○	○	○
71	TCS/ABS control unit	○	○	○*5	○	○*5	○
75	Total control signal (multiple signal) for engine, A/T and TCS/ABS	○	○	—	○	○	○
80	Engine speed signal	—	○*3	—	○	○	○
83	Monitoring of total control signal (multiple signal) for engine, A/T and TCS/ABS	○	○	—	○	○	○
84	Engine system component fuel condition	○	○	—	○	○	○
85	Incomplete start process of total control signal (multiple signal) for engine, A/T and TCS/ABS	○	○	—	○	○	○
86	Continuous start process of total control signal (multiple signal) for engine, A/T and TCS/ABS	○	○	—	○	○	○
No indication (no blinking)	Remains OFF: Data link connector circuit	○	○	—	—	—	—*4
	Remains ON: SLIP indicator lamp circuit shorted, TCS/ABS control unit or self-diagnostic check terminal circuit open	○	○	○	○	○	—*4

**NOTE:**

When the malfunction code No. 58 is indicated, perform the throttle control unit self-diagnosis. When the malfunction code Nos. 75, 80, 83, 84, 85 or 86 is indicated, perform the self-diagnosis for ECM-TCM or ECM.

\*1: Fail-safe operation is not activated. A signal from control unit suspends TCS and ABS control operation. Brakes operate conventionally and the vehicle operates in the same manner as a vehicle without the TCS. After specified battery voltage resumes, the TCS OFF indicator lamp and the ABS warning lamp go off, allowing for TCS and ABS control operation.

\*2: TCS operation only stops and fail-safe operation is activated, allowing for ABS control operation.

\*3: Malfunction is detected only when TCS is in operation.

\*4: When there are malfunctions in the self-diagnostic check terminal circuit (terminal 4 of the data link connector for CONSULT) and SLIP indicator lamp circuit, fail-safe operation is not activated.

\*5: Some malfunctions in the TCS/ABS control unit cause the SLIP indicator lamp and the ABS warning lamp to go off separately.

## CONSULT for Throttle Control Unit Control System

### CONTROL UNIT PART NUMBER

The part number that is shown on the control unit label and CONSULT: 23790 AA500

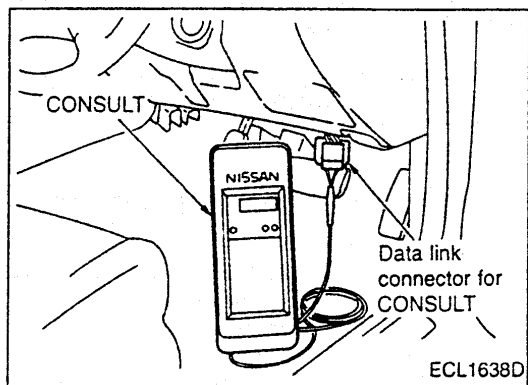

### SELF-DIAGNOSIS PROCEDURE

1. Collect information on the concern from the customer, and then perform basic inspections.
2. Turn ignition switch OFF and connect CONSULT connector to data link connector for CONSULT on the vehicle.
3. Start engine and drive vehicle at approx. 30 km/h for approx. 1 minute.
4. Stop vehicle with engine running and touch "START", "THROTTLE CONTROL" and "SELF-DIAG RESULTS" sequentially on the CONSULT screen.
  - If "START" is touched immediately after engine is started or ignition switch is turned on, "THROTTLE CONTROL" may not be displayed on "SELECT SYSTEM" screen. To display "THROTTLE CONTROL", repeat the self-diagnosis procedure from the beginning.
5. Self-diagnosis results are displayed on the screen. (Touch "PRINT" to print out the self-diagnosis results, if necessary.)
  - If "NO FAIL" is displayed, inspect SLIP indicator lamp, TCS OFF indicator lamp, and ABS warning lamp. Refer to BR-26.
6. Perform appropriate inspection from the self-diagnostic results mode and repair or replace faulty parts.
7. Start engine and drive vehicle at approx. 30 km/h for approx. 1 minute to ensure that there is no other malfunction in the system.
8. Turn ignition switch OFF to prepare for erasing the trouble stored in memory.
9. Start engine and touch "START", "THROTTLE CONTROL", "SELF-DIAG RESULTS" and "ERASE" sequentially on the CONSULT screen to erase the trouble stored in memory.
  - If the malfunction stored in memory is not erased, repeat step 6.
10. Drive vehicle at approx. 30 km/h for approx. 1 minute and then confirm that TCS OFF indicator lamp and SLIP indicator lamp is OFF.

## TCS/ABS SYSTEM

### CONSULT for Throttle Control Unit Control System (Cont'd)

#### SELF-DIAGNOSTIC RESULTS MODE

Diagnostic item	Diagnostic item is detected when...	Check item
THROTTLE POSI SEN	Throttle position sensor signal output is abnormally high or continues to stay low for a certain period of time.	Throttle position sensor circuit
THROTTLE MOTOR	Throttle motor sensor signal output is abnormally high or continues to stay low for a certain period of time.	Throttle motor sensor and circuit
THRTL OPEN TRGET	Circuit for throttle motor target angle signal (DKR line) is open or shorted. TCS/ABS control unit is abnormal.	Circuit for the communication line between the throttle control unit and the TCS/ABS control unit
THROTTLE ACTUATOR	Throttle motor operation does not accord with the throttle motor target angle.	
THROTTLE MOTOR	Overcurrent is applied to the throttle motor drive circuit.	Throttle motor and circuit
THROTTLE MOTOR RLY [SHORT]	Throttle motor relay is short-circuited.	Throttle motor relay and circuit
THROTTLE MOTOR RLY [OPEN]	Throttle motor relay is open.	
ENGINE START SIG	Start signal is not correctly entered due to short.	Start signal circuit and ECM-TCM or ECM
NEUTRAL POSI SW	Park/neutral position switch signal is not correctly entered due to open or shorted circuit.	Neutral position switch circuit and PNP switch circuit

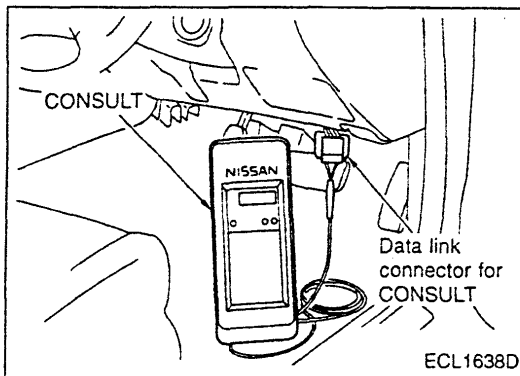

#### DATA MONITOR PROCEDURE

- Refer to CONSULT Instruction Manual for details on data monitor function.
1. Turn ignition switch OFF.
  2. Connect CONSULT connector to data link connector for CONSULT.
  3. Turn ignition switch ON.
  4. Touch "START" on CONSULT screen.
  5. Touch "THROTTLE CONTROL" on CONSULT screen.
  6. Touch "DATA MONITOR".
  7. Touch "SETTING" to set recording condition.
  8. Touch one key from "AUTO TRIG", "MANUAL TRIG" and "SPECIAL", and then touch "LONG TIME".
- With "AUTO TRIG" selected, the data is automatically recorded if a malfunction occurs during the data monitor. With "SPECIAL" selected, the data is automatically recorded when TCS is activated.
9. Touch "ENTER".
  10. Return to "SELECT MONITOR ITEM" screen and touch "ALL SIGNALS".
  11. Display data monitor.
  12. If necessary, sequentially touch "REC START", "REC STOP", "DATA DISPLAY", "NUMBER PRINT" and "PRINT" to print out the data.

# TCS/ABS SYSTEM

## CONSULT for Throttle Control Unit Control System (Cont'd)

### DATA MONITOR MODE

Display	Select monitor item	Remarks	
		All signals	Selection from menu
THRTL POS SEN [V]	○	△	Displays throttle position sensor signal voltage.
THRTL OPENING [°]	○	△	Displays throttle angle computed based on throttle position sensor signal voltage.
THRTL POS SE2 [V]	○	△	Displays throttle motor sensor signal voltage.
THRL2 OPENING [°]	○	△	Displays throttle motor angle computed based on throttle motor sensor signal voltage.
BATTERY VOLT [V]	○	△	Displays the battery voltage for the control unit.
TH OPEN SIG [ms]	○	△	Displays the pulse width of the throttle motor target angle signal from the TCS/ABS control unit.
CLOSED THL/SW [ON/OFF]	○	△	Indicates the switch status (ON/OFF) based on the throttle position sensor signal.
NEUT POSI SW [ON/OFF]	○	△	Indicates the switch status (ON/OFF) based on the park/neutral position switch signal.
START SIGNAL [ON/OFF]	○	△	Indicates the status (ON/OFF) based on the starter signal.
TH OPEN CONT [°]	○	△	Displays the throttle motor control target computed by the control unit based on each input signal.
TH MOTOR DUTY [%]	○	△	Indicates the throttle motor drive duty.
TH MOTOR RLY [ON/OFF]	○	△	Indicates the throttle motor relay status (ON/OFF).
TCS SIGNAL [ON/OFF]	○	△	Indicates ON when the throttle motor angle reaches a specified lower limit.
TCS FLAG	○	△	Indicates "VALID" when throttle motor target angle signal is received from the TCS/ABS control unit and the throttle control unit closes the throttle motor.
COMM COND [ON/OFF]	○	△	Indicates the condition of the communication between TCS/ABS control unit and throttle control unit. Normally ON is indicated, and OFF is shown when there is failure.
TH CLSD LRN [DONE/YET]	○	△	Indicates if the throttle motor has been fully closed before. "DONE" is indicated when it has, and "YET" is shown when it has not yet.
VOLTAGE [V]		△	Indicates the voltage measured with a voltage probe.
PULSE [ms, Hz, %]	—	△	Indicates the pulse measured with a pulse probe. If it cannot be measured, "%" is shown on the display. The "%" mark is also shown to the left of the final data until the measuring result is output.

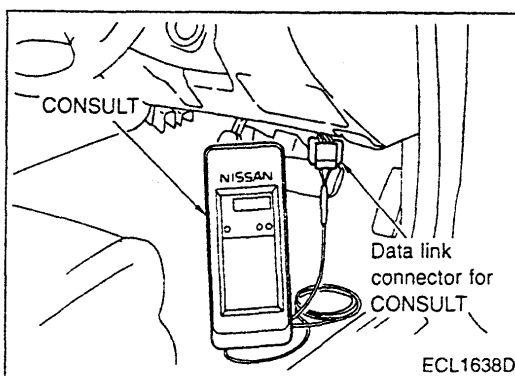

### ACTIVE TEST PROCEDURE

1. Turn ignition switch OFF.
2. Connect CONSULT connector to data link connector for CONSULT.
3. Turn ignition switch ON.
4. Touch "START" on CONSULT screen.
5. Touch "THROTTLE CONTROL" on CONSULT screen.

# TCS/ABS SYSTEM

## CONSULT for Throttle Control Unit Control System (Cont'd)

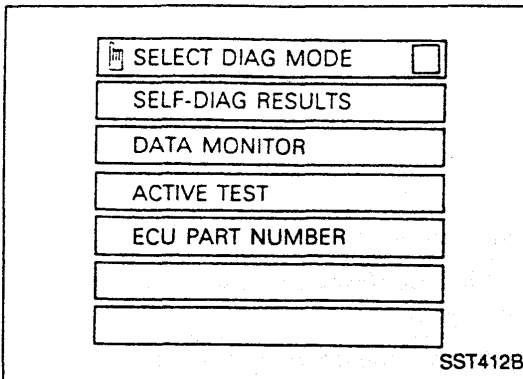

6. Touch "ACTIVE TEST".

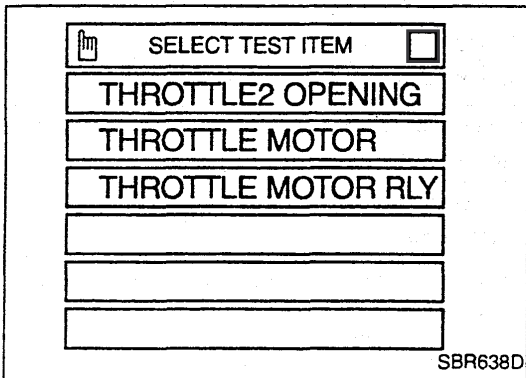

7. Touch "MOTOR THROTTLE OPEN" on the "SELECT TEST ITEM" screen.

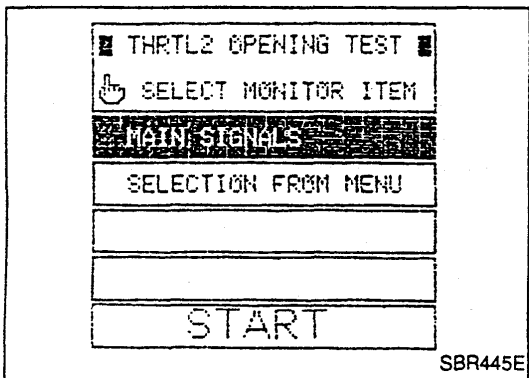

8. Touch "START" with "MAIN SIGNALS" reversed.

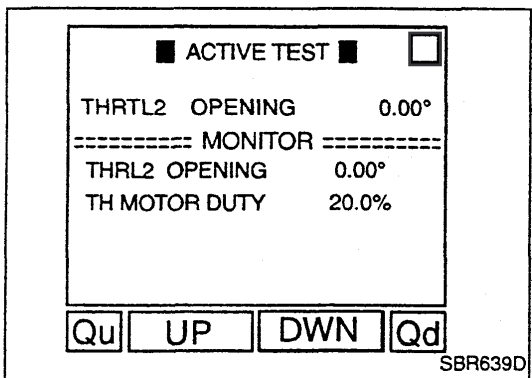

9. Set the motor throttle target angle to 0° (fully closed).  
● The motor throttle target angle shown on the screen is 2°.

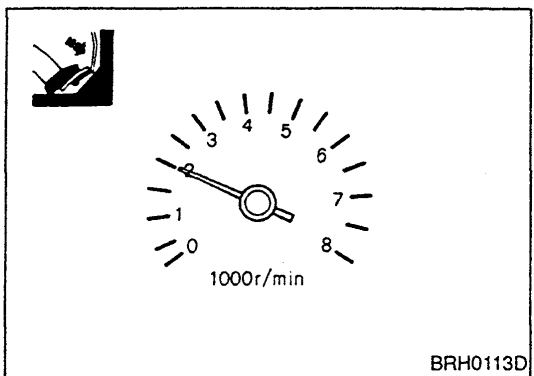

10. After the steps above, confirm that the engine speed is limited when the acceleration pedal is depressed.

11. As shown above, change the motor throttle angle several times while observing the limitation of the engine speed in accordance with the throttle angle.

## Self-diagnosis for Throttle Control Unit Control System

### SELF-DIAGNOSIS PROCEDURE

1. Turn ignition switch ON or start the engine to start self-diagnosis.
2. The control unit LED comes on to indicate the malfunction code No.
3. Verify the location of the malfunction with "MALFUNCTION CODE/SYMPTOM CHART", BR-42. Then make the necessary repairs.
4. After the malfunctions are repaired, erase the malfunction codes stored in the control unit. Refer to "HOW TO ERASE SELF-DIAGNOSTIC RESULTS" shown below.
5. Turn ignition switch OFF and then turn ignition switch ON or start the engine to verify that the malfunction codes have been erased.
6. Verify that SLIP indicator lamp and TCS indicator lamp are OFF.

### HOW TO READ SELF-DIAGNOSTIC RESULTS (Malfunction codes)

- Determine the code No. by observing the time and the frequency that the throttle control unit LED blinks ON and OFF. When multiple malfunctions occur at a time, all the code numbers can be stored. The indication begins with the start code No. 12, followed by the stored malfunction codes. The smallest number of the stored codes appears first and the others follow sequentially. The indication then returns to the start code No. 12 to repeat.
- The malfunction code No. 55 is only indicated repeatedly when there is no malfunction.

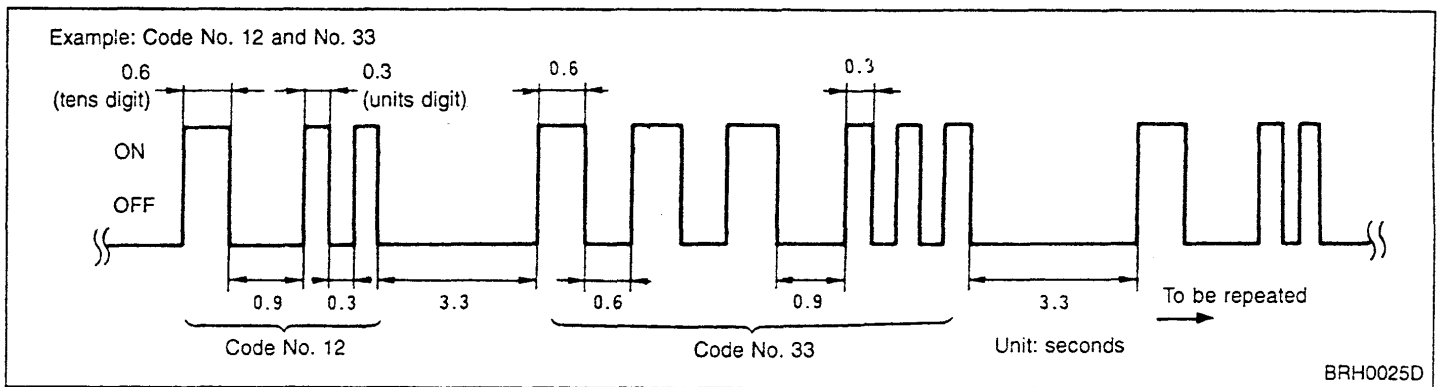

### HOW TO ERASE SELF-DIAGNOSTIC RESULTS (Malfunction codes)

1. With the throttle fully open, turn the neutral position switch OFF (or a position other than P and N).
  2. Turn ignition switch ON without starting the engine. Then, turn the park/neutral position switch ON (or P or N) and release the acceleration pedal.
- As for the following items, self-diagnostic results can be erased if the conditions in the chart are met. In this case the steps above are not necessary.

Malfunction code No.	Malfunctioning part	Condition
13	Circuit for the communication line (DKR line) between the TCS control unit and the throttle control unit	Normal communication synchronicity is achieved.
31	Start signal circuit	The start signal is detected next time the ignition switch is turned ON.
33	Park/neutral position switch circuit	Park/neutral position switch operation is detected next time the ignition switch is turned ON.



## TCS/ABS SYSTEM

### Self-diagnosis for Throttle Control Unit Control System (Cont'd)

#### MALFUNCTION CODE/SYMPTOM CHART

Malfunction code No.	Malfunctioning part	Lamp ON			Fail-safe operation
		SLIP	TCS OFF	ABS	
11	Throttle position sensor circuit	○	○	—	○
12	Throttle motor sensor circuit	○	○	—	○
13	Circuit for the communication line between TCS/ABS control unit and throttle control unit	○	○	—	○
21	Actuator system (Motor circuit is open or throttle motor intermittently works.)	○	○	—	○
22	Throttle motor drive system (overcurrent)	○	○	—	○
23	Throttle motor relay circuit (shorted)	○	○	—	○
24	Throttle motor relay circuit (open)	○	○	—	○
31*	Start signal circuit	—	—	—	—
32	Throttle motor return spring	○	○	—	○
33*	Park/neutral position switch circuit	—	—	—	—
55	Normal	—	—	—	—

\*: Even when start signal circuit or park/neutral position switch circuit is abnormal, TCS operates properly. LED only blinks to indicate the location of the malfunction.

# STEERING SYSTEM

## SECTION **ST**

GI

EC

AT

BR

**ST**

RS

HA

EL

SD

## CONTENTS

<b>ELECTRIC SUPER HICAS</b> .....	2	Control Unit Input/Output Signal Specifications .....	5
Pre-inspection .....	2	Preliminary Check.....	7
System Description.....	2	Trouble Diagnosis with CONSULT .....	7
Component Parts Location.....	3	Trouble Diagnosis with Self-diagnosis.....	12
Circuit Diagram .....	4	Symptom Chart.....	14

## Pre-inspection

### INSPECTION BEFORE DRIVING

- Check fluid leakage from power steering components (gear, pump, piping, etc.), and check whether the fluid level is within the proper range.
- Check whether tire size and inflation pressure are within the specified limits. Check also whether the steering wheel is a genuine part, and whether a non-genuine control unit is attached.
- Check whether wheel alignment is within the specified limits.
- Check whether suspension system is modified, and whether the modification, if any, has increased the vehicle weight.

### INSPECTION DURING DRIVING

- Check facts about trouble (what, when, where, who, why and how).
- Check whether the engine is running in good condition.

## System Description

This system contains two functions for SUPER HICAS: self-diagnosis function and fail-safe function. For self-diagnosis function, refer to "SELF-DIAGNOSIS PROCEDURE" on pages ST-7 and ST-12.

### FAIL-SAFE FUNCTION

If the system detects some error, it halts the normal control and enters the fail-safe mode. In this event, the system notifies the driver of a malfunction by turning ON the HICAS warning lamp. The fail-safe mode is canceled when ignition switch is turned OFF. If, however, the fail-safe mode is caused by a vehicle speed signal error, it is automatically canceled when the signal is restored before the ignition switch is turned OFF.

### HICAS WARNING LAMP

When the system is in normal condition, HICAS warning lamp is turned ON by switching the ignition ON, and is turned OFF after engine has started.

## Component Parts Location

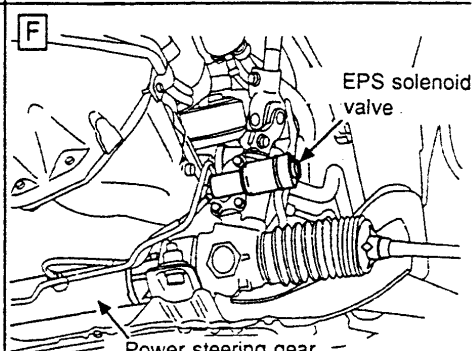
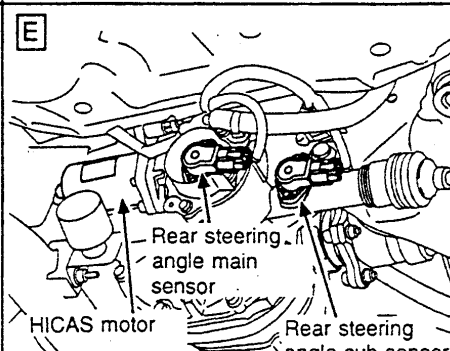
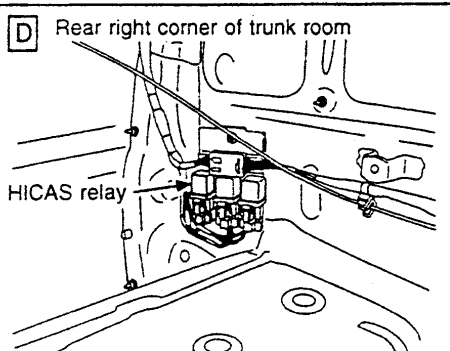
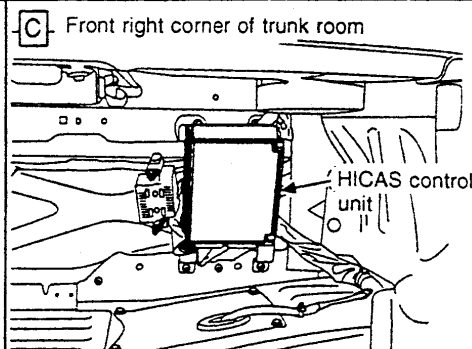
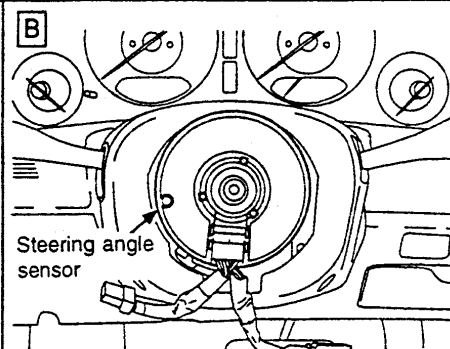
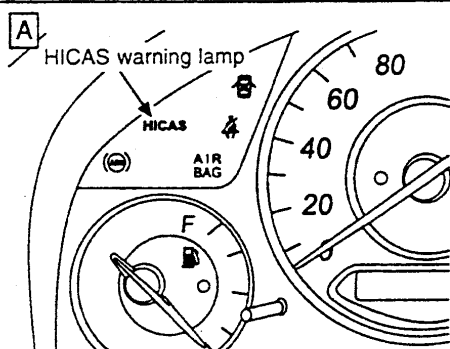
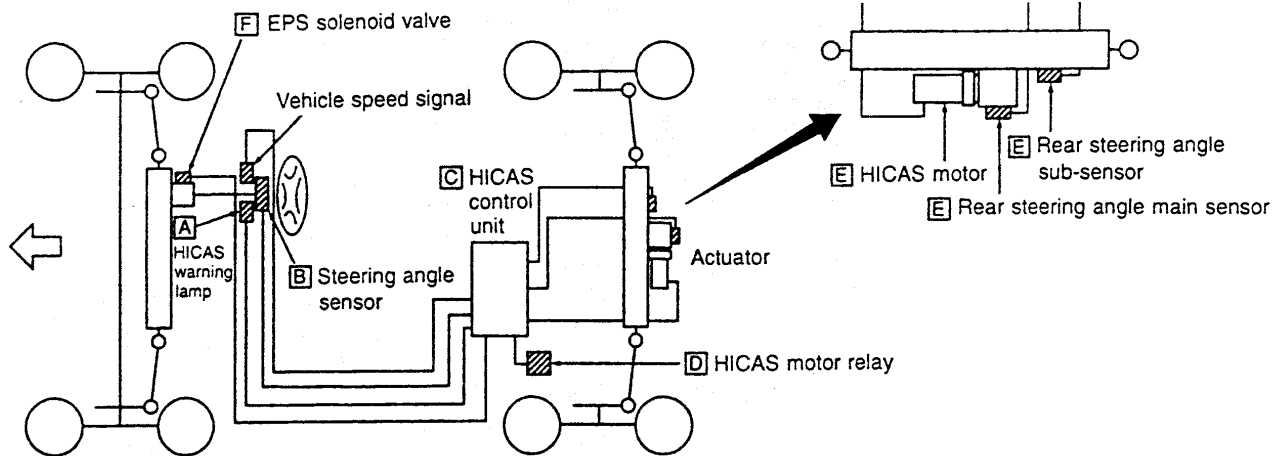

STE0414D

Circuit Diagram

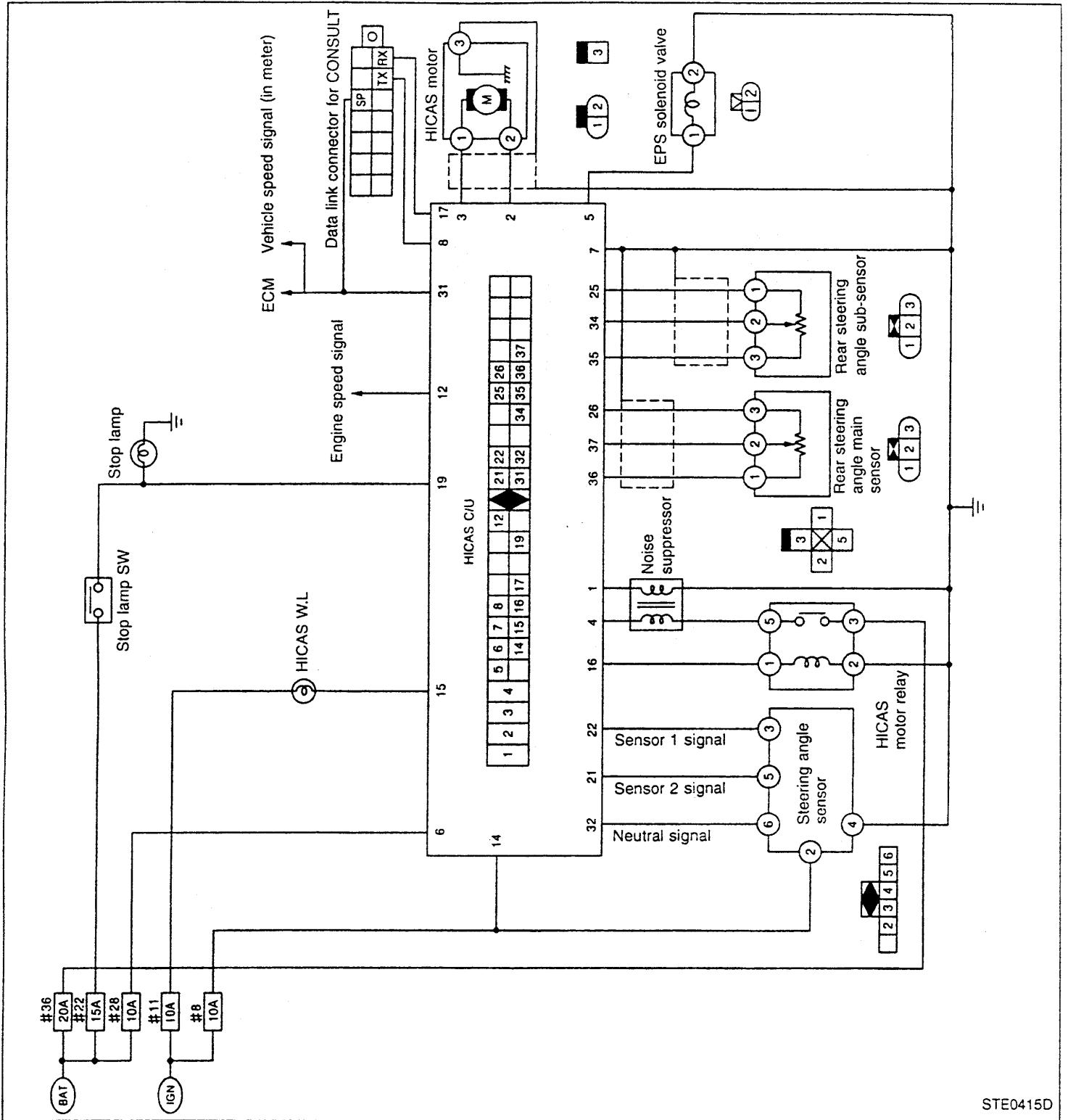

STE0415D

# ELECTRIC SUPER HICAS

## Control Unit Input/Output Signal Specifications USING CIRCUIT TESTER

1	2	3	4	5	6	7	8	9	10	11	12	◆	21	22	23	24	25	26	27	28	29	30
				13	14	15	16	17	18	19	20	◆	31	32	33	34	35	36	37	38	39	40

STE0401D

Terminal No.		Check item	Specification
+	-		
1 7	Body ground	Control unit ground circuit	When control unit is disconnected : Continuity exists.
2 3		Motor driving output signal	
4		Motor voltage	When ignition switch is ON : Power supply voltage (In fail-safe mode : 0V)
5		EPS solenoid driving signal	When vehicle speed is 0 km/h : Approx. 4.4 - 6.6V When vehicle speed is 100 km/h : Approx. 2.4 - 3.6V
6		Battery voltage	Power supply voltage
8			Data link connector for CONSULT (TX)
12	—	Engine speed signal	Measure tachometer driving signal. Refer to EC section ["ECM (TCM) Input/Output Signal Reference Value"] .
14	Body ground	Ignition voltage	When ignition switch is ON : Power supply voltage When ignition switch is OFF : 0V
15		HICAS warning lamp	When HICAS warning lamp is ON : Approx. 0V When HICAS warning lamp is OFF : Approx. 12V
16		Output signal for driving motor relay	When ignition switch is ON : Approx. 12V (In fail-safe mode : Approx. 0V)
17	—	Data link connector for CONSULT (RX)	—
19	Body ground	Stop lamp switch signal (Send brake pedal operation signal to control unit.)	When pedal is depressed : Power supply voltage When pedal is not depressed : 0V
21		Steering angle sensor 2	When steering wheel is turned, the voltage changes between 0 and 5V.
22		Steering angle sensor 1	
25 26		Ground circuit for rear steering angle sensor	Continuity exists.
32		Neutral signal of rear steering angle sensor	When neutral : Approx. 5V
34 37		Output signal of rear steering angle sensor	When neutral : Approx. 2.4V
35 36		Power supply for rear steering angle sensor	When ignition switch is ON : Approx. 5V When ignition switch is OFF : Approx. 0V

GI

EC

AT

BR

ST

RS

HA

EL

SD

# ELECTRIC SUPER HICAS

## Control Unit Input/Output Signal Specifications (Cont'd)

### USING CONSULT

The displayed output signals represent the control unit computed data. If the output circuit (harness) should be open, correct values may be displayed.

Monitor item	Data monitor		Check item
	Condition	Specification	
VHCL SPEED SE [km/h]	Vehicle is running or driving wheels are turning.	Approximately equal to speedometer reading	Vehicle speed sensor circuit
STEERING ANG [R/L]	Steering wheel is turned right or left.	Steering angle (degrees) measured from neutral position	Steering angle sensor circuit
NEUTRAL SIG [ON-OFF]	Steering wheel is in neutral position or turned right or left.	When neutral: ON When turned (right or left): OFF	
STOP LAMP SW [ON-OFF]	Brake pedal operation	When pedal is depressed: ON When pedal is not depressed: OFF	Stop lamp switch circuit
ENGINE SPEED [rpm]	Engine is running.	Approximately equal to tachometer reading	Wiring in ECM-HICAS control unit
RR ST ANG-MAI [V]	Actuator is operating in active test.	In neutral position: Approx. 2.4V	Rear steering angle sensing system
RR ST ANG-SUB [V]		In right lock position: Approx. 4.4V In left lock position: Approx. 0.4V	
POWER STR SOL [A]	Vehicle speed is changed from 0 to 100 km/h.	At 0 km/h: Approx. 1.10A At 100 km/h: Approx. 0.48A	System related to power steering solenoid output signal
MOTOR CURRENT [A]	Actuator is operating in active test.	OK if output current is detected during operation	Motor and its power supply system
HICAS RELAY [ON-OFF]	Ignition switch is ON or engine is running.	When ignition switch is ON: ON	Power supply system for HICAS motor relay System related to relay driving signal from control unit
FAILSAFE [ON-OFF]		Not in operation	Check malfunctioning parts using self-diagnosis and data monitor.
WARNING LAMP [ON-OFF]		When warning lamp is ON: ON When warning lamp is OFF: OFF	Warning lamp circuit
RR ST ANG-VOL [V]		Approx. 5V	Rear steering angle sensing system
MOTOR VOLTAGE [V]		Power supply voltage	Motor power supply system
C/U VOLTAGE [V]	Ignition switch is ON or engine is running.	Power supply voltage	Control unit power supply circuit

# ELECTRIC SUPER HICAS

## Preliminary Check

1. Check HICAS actuator for improper attachment and conditions.
  - Check the actuator for loose fasteners, damage in actuator body, rods and dust boots, and grease leaks.
2. Check suspension system for improper attachment of links and excessive play in axles.
3. Check all connectors for improper connections.
4. Conduct inspection using self-diagnosis function.

## Trouble Diagnosis with CONSULT

### DESCRIPTION

The trouble diagnoses have four modes: Self-diagnosis, Data monitor, Active test and ECM Part Number modes.

Mode	Function	Mode switching	Display
SELF-DIAGNOSTIC RESULTS	<ul style="list-style-type: none"> <li>● Displays results of self-diagnosis.</li> </ul>	Mode is switched simply by touching the CONSULT screen.	The CONSULT screen displays the data.
DATA MONITOR	<ul style="list-style-type: none"> <li>● Used to find main causes of trouble, based on the result of self-diagnosis.</li> <li>● Monitors, records and prints the input and output of HICAS control unit.</li> </ul>		
ACTIVE TEST	<ul style="list-style-type: none"> <li>● Used to find main causes of trouble, based on the result of data monitor.</li> <li>● Used to check the operation of actuator by sending driving signals to it.</li> </ul>		
ECM PART NUMBER	<ul style="list-style-type: none"> <li>● Displays the part number of control unit.</li> </ul>		

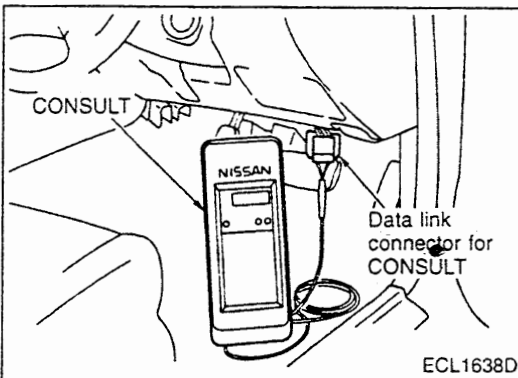

### SELF-DIAGNOSIS PROCEDURE

1. After connecting CONSULT to data link connector, start the engine.
2. Touch START (on CONSULT display).
3. Touch HICAS.
4. Touch SELF-DIAG RESULTS.
  - Refer to CONSULT operation manual "HICAS" for details.

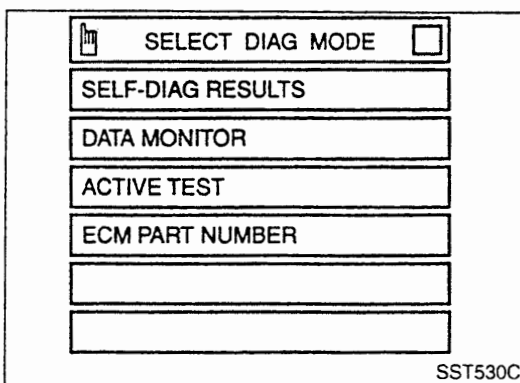



# ELECTRIC SUPER HICAS

## Trouble Diagnosis with CONSULT (Cont'd) SELF-DIAGNOSTIC RESULTS MODE

Diagnostic item	Diagnostic item is detected when...	Remarks
VEHICLE SPEED SEN [SIGNAL TURN](-b)	<ul style="list-style-type: none"> <li>Vehicle speed signal changes rapidly during running.</li> </ul>	
CODE 54	<ul style="list-style-type: none"> <li>Vehicle speed signal is not sensed for more than 10 seconds while the vehicle is running at 1,500 rpm of engine speed.</li> </ul>	This code appears also when engine is idling at 1,500 rpm or faster for more than 10 seconds; in this case, it does not indicate abnormality.
STEERING ANGLE SEN [NO ANG SIG](-a)	<ul style="list-style-type: none"> <li>Steering angle does not change for a while when vehicle is running at 60 km/h or faster.</li> </ul>	
STEERING ANGLE SEN [ANG SIG FIX](-e)	<ul style="list-style-type: none"> <li>Steering angle from neutral position is kept at 60° degrees or more for a certain time when vehicle is running at 50 km/h or faster.</li> </ul>	
STEERING ANGLE SEN [ANG FIX30°](-g)	<ul style="list-style-type: none"> <li>Steering angle from neutral position is kept at 30° degrees or more while vehicle travels a certain distance.</li> </ul>	
STEERING ANGLE SEN [NO NEUT SIG](-b)	<ul style="list-style-type: none"> <li>No neutral signal (ON signal) is sensed while vehicle travels a certain distance.</li> </ul>	
STEERING ANGLE SEN [NEU SIG OFF](-c)	<ul style="list-style-type: none"> <li>No neutral signal (ON signal) is sensed while steering wheel is turned more than 360°.</li> </ul>	
STEERING ANGLE SEN [NEUT SIG ON](-d)	<ul style="list-style-type: none"> <li>No neutral signal (OFF signal) is sensed while steering wheel is turned more than 50° degrees.</li> </ul>	
STEERING ANGLE SEN [OFFSET NEUT](-f)	<ul style="list-style-type: none"> <li>When steering wheel is turned 360° after the detection of neutral signal, the neutral signal is sensed for a certain period of time.</li> </ul>	
RR ST ANGLE SENSOR [MAIN SIGNAL](-a)	<ul style="list-style-type: none"> <li>For a certain period of time, input signal from main sensor shows abnormality against sensor power supply voltage.</li> </ul>	
RR ST ANGLE SENSOR [SUB SIGNAL](-b)	<ul style="list-style-type: none"> <li>When input signal from main sensor shows <math>2.5 \pm 1V</math>, input signal from sub-sensor shows abnormality against sensor power supply voltage for a certain period of time.</li> </ul>	
RR ST ANGLE SENSOR [OFFSET SIG](-c)	<ul style="list-style-type: none"> <li>Input signals from main sensor and sub-sensor show more than a certain amount of difference from each other.</li> </ul>	
RR ST ANGLE SENSOR [ABNORMAL VOL](-d)	<ul style="list-style-type: none"> <li>The voltage is higher or lower than the standard value.</li> </ul>	
ENG REV SIGNAL [ABNORMAL SIGNAL]	<ul style="list-style-type: none"> <li>Engine speed shows an abnormally low value for a certain period of time when vehicle is running at 2 km/h or faster.</li> </ul>	
MOTOR VOLTAGE [LOW VOLTAGE](-a)	<ul style="list-style-type: none"> <li>When HICAS motor relay is ON, motor power supply voltage shows an abnormally lower value than ignition power supply voltage.</li> </ul>	
MOTOR VOLTAGE [BAD OBSTRCT](-b)	<ul style="list-style-type: none"> <li>When control unit keeps motor power OFF, the motor power voltage shows a non-zero value for a certain period of time.</li> </ul>	
MOTOR OUTPUT [ABNORML SIG](-a)	<ul style="list-style-type: none"> <li>When a motor current is more than 10A, the actual output of the motor shows an abnormally low value for a certain period of time.</li> </ul>	
MOTOR OUTPUT [REV CURRENT](-c)	<ul style="list-style-type: none"> <li>When motor output is kept ON, a reverse current is flowing.</li> </ul>	

# ELECTRIC SUPER HICAS

## Trouble Diagnosis with CONSULT (Cont'd)

Diagnostic item	Diagnostic item is detected when...	Remarks
MOTOR OUTPUT [NO CURRENT](d)	<ul style="list-style-type: none"> <li>When motor output is kept OFF, a current is flowing.</li> </ul>	
MOTOR OUTPUT [OVERCURRENT](e)	<ul style="list-style-type: none"> <li>When motor output is kept ON, an overcurrent is flowing.</li> </ul>	
MOTOR OUTPUT [MOTOR LOCK](b)	<ul style="list-style-type: none"> <li>Signal from rear steering angle sensor does not change for a certain period of time while a motor current of 17A or more is flowing.</li> </ul>	
VEHICLE SPEED SEN [RAPD SIGN CHANGE2]	<ul style="list-style-type: none"> <li>When vehicle is running, vehicle speed signal is not sensed for a certain period of time after it has changed rapidly.</li> </ul>	
VEHICLE SPEED SEN [NO SIGNAL2]	<ul style="list-style-type: none"> <li>"VEHICLE SPEED SEN [RPD SIG CHG2]" has occurred previously, and vehicle speed signal is not sensed for a certain period of time.</li> </ul>	
VEHICLE SPEED SEN [NO SIGNAL3]	<ul style="list-style-type: none"> <li>"VEHICLE SPEED SEN [RPD SIG CHG2]" has not occurred previously, and vehicle speed signal is not sensed for a certain period of time while the vehicle is running at 1,500 rpm of engine speed.</li> </ul>	
CONTROL UNIT [ABNORMAL 1-6]	<ul style="list-style-type: none"> <li>Control unit is malfunctioning.</li> </ul>	

GI

EC

AT

BR

ST

RS

HA

EL

SD

# ELECTRIC SUPER HICAS

## Trouble Diagnosis with CONSULT (Cont'd) DATA MONITOR PROCEDURE

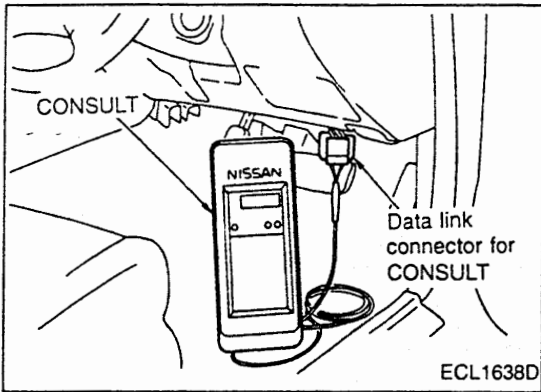

1. After connecting CONSULT to data link connector, start the engine.

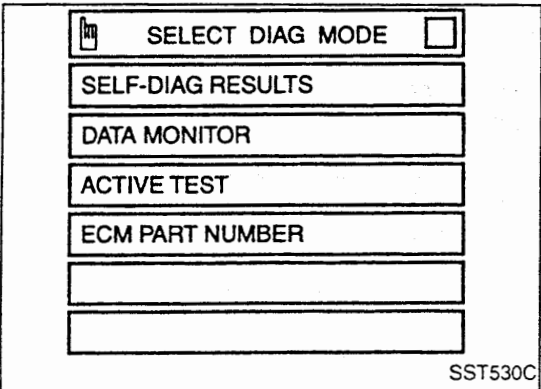

2. Touch "START", "HICAS" and "DATA MONITOR".

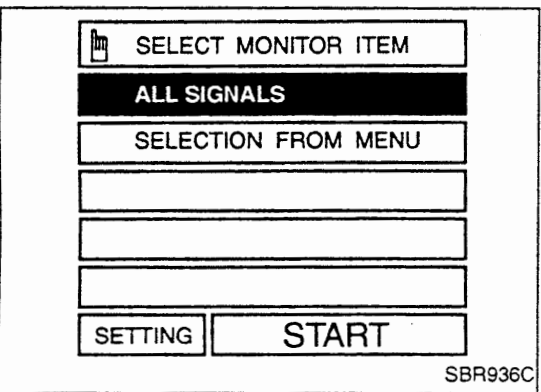

3. Select items to be monitored.

(1) When "ALL SIGNALS" is selected, touch "START".

(2) When "SELECTION FROM MENU" is touched, "SELECT TEST ITEM" screen appears. Touch appropriate items on that screen, and touch "ENTER" and "START".

(3) Touch "PRINT", if printout is required.

# ELECTRIC SUPER HICAS

## Trouble Diagnosis with CONSULT (Cont'd) DATA MONITOR MODE

Display	Monitor item		Remarks
	Main item	Menu item	
VHCL SPEED SE (km/h)	<input type="radio"/>	<input type="radio"/>	Shows a value calculated from vehicle speed sensor signal.
STEERING ANG (R/L°)	<input type="radio"/>	<input type="radio"/>	After battery has been disconnected and connected again, an abnormal value is shown until neutral position (0°) is detected.
NEUTRAL SIG (ON-OFF)	<input type="radio"/>	<input type="radio"/>	Shows whether steering wheel is in neutral position (ON/OFF).
STOP LAMP SW (ON-OFF)	<input type="radio"/>	<input type="radio"/>	Shows whether stop lamp switch is ON or OFF.
ENGINE SPEED (rpm)	<input type="radio"/>	<input type="radio"/>	Shows the engine speed calculated from crankshaft position sensor signal.
RR ST ANG-MAI (V)	<input type="radio"/>	<input type="radio"/>	Shows the output voltage from rear steering angle main sensor.
RR ST ANG-SUB (V)	<input type="radio"/>	<input type="radio"/>	Shows the output voltage from rear steering angle sub-sensor.
POWER STR SOL (A)	<input type="radio"/>	<input type="radio"/>	Shows the control unit's control current for power steering solenoid.
MOTOR CURRENT (A)	<input type="radio"/>	<input type="radio"/>	Shows the control unit's control current for HICAS motor relay.
HICAS RELAY (ON-OFF)	<input type="radio"/>	<input type="radio"/>	Shows whether HICAS motor relay is ON or OFF.
FAILSAFE (ON-OFF)	<input type="radio"/>	<input type="radio"/>	Shows whether fail-safe function is in operation (ON/OFF).
WARNING LAMP (ON-OFF)	<input type="radio"/>	<input type="radio"/>	Shows the control unit's ON-OFF status of HICAS warning lamp.
RR ST AGN-VOL (V)	<input type="radio"/>	<input type="radio"/>	Shows the power supply voltage from HICAS control unit to rear steering angle sensor.
C/U VOLTAGE (V)	<input type="radio"/>	<input type="radio"/>	Shows the power supply voltage to HICAS control unit.
MOTOR VOLTAGE (V)	<input type="radio"/>	<input type="radio"/>	Shows the power supply voltage from HICAS control unit to HICAS motor.
VOLTAGE (V)	—	<input type="radio"/>	Shows the measured value by voltage probe.
PULSE (ms, Hz and %)	—	<input type="radio"/>	Shows the measured value by pulse probe. If measurement is impossible, “#” appears. The “#” mark is shown also on the left of final data until measurement is completed.

GI

EC

AT

BR

ST

RS

HA

EL

SD

# ELECTRIC SUPER HICAS

## Trouble Diagnosis with CONSULT (Cont'd)

### ACTIVE TEST PROCEDURE

1. After connecting CONSULT to data link connector, start the engine.

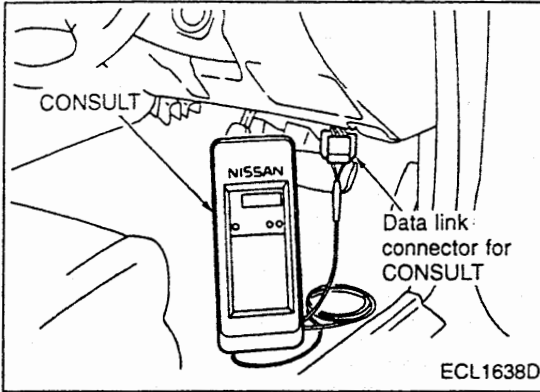

2. Touch "START", "HICAS" and "ACTIVE TEST".

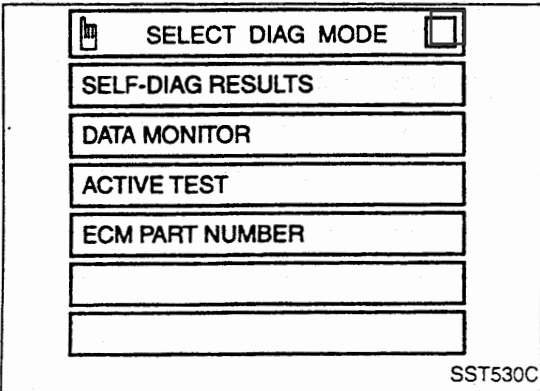

3. Touch "SIMULATE" and "SELECT MONITOR ITEM".
4. Turn the steering wheel right or left to make the rear actuator operate.

### Reference values in normal condition

Steering angle sensor	Rear steering angle main sensor	Rear steering angle sub-sensor	Motor current
0° (Neutral)	2.4V	2.4V	No (Approx. 0V)
R 90°	4.4V	4.4V	Yes (Variable)
L 90°	0.4V	0.4V	

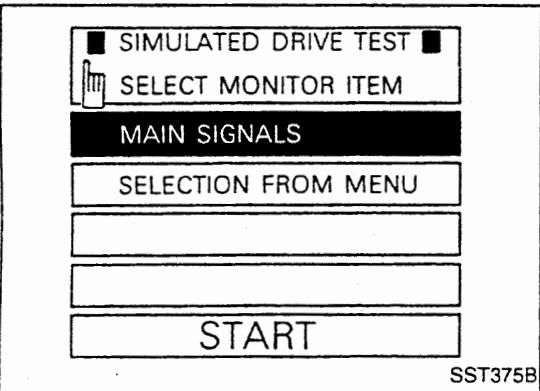

### ECM PART NUMBER

1. After connecting CONSULT to data link connector, turn ignition switch ON.
2. Touch "START", "HICAS" and "ECM PART NUMBER".
  - Part number printed on the control unit label and part number shown on the CONSULT screen are as follows:  
2-door model: 28505 AA100  
4-door model: 28505 AA110

## Trouble Diagnosis with Self-diagnosis

### DESCRIPTION

If the system detects some error while vehicle is running, it notifies the driver of a malfunction by turning ON the HICAS warning lamp, and at the same time, it halts the normal control and enters the fail-safe mode.

### SELF-DIAGNOSIS PROCEDURE

1. Start the engine.
2. Within 10 seconds after the engine has started, turn the steering wheel more than 20° right-to-left and repeat this 5 times or more, and then depress the brake pedal 5 times or more.

## Trouble Diagnosis with Self-diagnosis (Cont'd) DIAGNOSTIC ITEM INPUT

1. Move the vehicle one or two meters at a very low speed.
2. Turn the steering wheel more than 20° right-to-left once or more.

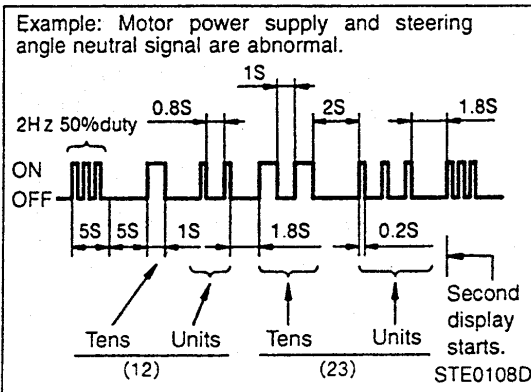

### DISPLAY OF SELF-DIAGNOSTIC RESULTS

The results of self-diagnosis are shown by flash patterns of HICAS warning lamp.

#### Display when past data shows that fail-safe function has been activated previously

- Only an abnormal item is indicated by the pattern shown in the left figure. The pattern is repeated.

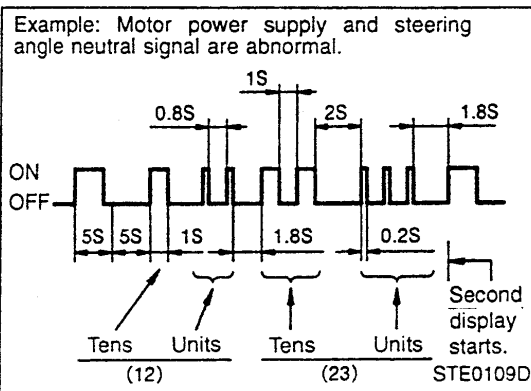

#### Display when past data shows that fail-safe function has not been activated previously

- If all items are normal, HICAS warning lamp flashes at a frequency of 4 Hz.
- If system is in fail-safe mode, only an abnormal item is indicated by the pattern shown in the left figure. The pattern is repeated.

### MALFUNCTION CODE CHART

Malfunction code No.	Diagnostic item
11	Control unit
12	Motor power supply
13	Motor output
21	Vehicle speed signal
22	Steering angle signal
23	Steering angle neutral signal
24	Rear steering angle main sensor signal
25	Rear steering angle sub-sensor signal
33	Engine speed signal

### HOW TO ERASE SELF-DIAGNOSTIC RESULTS

If past record shows that fail-safe function has been activated previously, use CONSULT, or leave the battery disconnected for more than 30 minutes to clear the memory.

# ELECTRIC SUPER HICAS

## Symptom Chart

Self-diagnosis		CONSULT	Diagnostic item																	
Mal-function code No.	Diagnostic item	Diagnostic item	Inspection 1	Inspection 2	Inspection 3	Inspection 4	Inspection 5	Inspection 6	Inspection 7	Self-diagnosis	Control unit circuit check	Stop lamp switch circuit check	Steering angle sensor circuit check	Warning lamp circuit check	Meter circuit check	Engine speed signal circuit check	Vehicle speed signal check (Inspection 4)	Actuator assembly check		
11	Control unit	CONTROL UNIT [ABNORMAL 1-6]	○																	
12	Motor power supply	MOTOR VOLTAGE [LOW VOLTAGE](-a)		○																
		MOTOR VOLTAGE [BAD OBSTRCT](-b)		○																
13	Motor output	MOTOR OUTPUT [ABNORML SIG](-a)			○															
		MOTOR OUTPUT [MOTOR LOCK](-b)			○															
		MOTOR OUTPUT [REV CURRENT](-c)			○															
		MOTOR OUTPUT [NO CURRENT](-d)			○															
		MOTOR OUTPUT [OVERCURRENT](-e)			○															
21	Vehicle speed signal	CODE 54				○														
		VEHICLE SPEED SEN [NO SIGNAL2]				○														
		VEHICLE SPEED SEN [NO SIGNAL3]				○														
		VEHICLE SPEED SEN [SIGNAL TURN](-b)				○														
		VEHICLE SPEED SEN [RPD SIG CHG2]				○														
22	Steering angle signal	STEERING ANGLE SEN [NO ANG SIG](-a)					○													
		STEERING ANGLE SEN [ANG SIG FIX](-b)					○													
		STEERING ANGLE SEN [ANG FIX30°](-g)					○													
23	Steering angle neutral signal	STEERING ANGLE SEN [NO NEUT SIG](-b)					○													
		STEERING ANGLE SEN [NEUT SIG OFF](-c)					○													
		STEERING ANGLE SEN [NEUT SIG ON](-d)					○													
		STEERING ANGLE SEN [OFFSET NEUT](-f)					○													
24	Rear steering angle main sensor signal	RR ST ANGLE SENSOR [MAIN SIGNAL](-a)						○												
		RR ST ANGLE SENSOR [ABNORML VOL](-d)						○												
		RR ST ANGLE SENSOR [OFFSET SIG](-c)						○												
25	Rear steering angle sub-sensor signal	RR ST ANGLE SENSOR [SUB SIGNAL](-b)						○												
		RR ST ANGLE SENSOR [ABNORML VOL](-d)						○												
		RR ST ANGLE SENSOR [OFFSET SIG](-c)						○												
33	Engine speed signal	ENG REV SIGNAL [ABNORMAL SIGNAL]							○											

# ELECTRIC SUPER HICAS

## Symptom Chart (Cont'd)

Diagnostic item		Inspection 1	Inspection 2	Inspection 3	Inspection 4	Inspection 5	Inspection 6	Inspection 7	Self-diagnosis	Control unit circuit check	Stop lamp switch circuit check	Steering angle sensor circuit check	Warning lamp circuit check	Meter circuit check	Engine speed signal circuit check	Vehicle speed signal check (Inspection 4)	Actuator assembly check
Malfunction code No.	Diagnostic item	Diagnostic item															
		Cannot enter self-diagnosis mode.									<input type="radio"/>	<input type="radio"/>	<input type="radio"/>				
	HICAS warning lamp is not turned ON by switching the ignition ON.									<input type="radio"/>			<input type="radio"/>	<input type="radio"/>			
	HICAS warning lamp is turned ON by switching the ignition ON but is not turned OFF by starting the engine.								<input type="radio"/>	<input type="radio"/>	<input type="radio"/>	<input type="radio"/>		<input type="radio"/>	<input type="radio"/>		
	Illumination of HICAS warning lamp has occurred after engine started.								<input type="radio"/>								
	Steering effort does not change with vehicle speed.								<input type="radio"/>		<input type="radio"/>					<input type="radio"/>	
	There is an abnormal noise.								<input type="radio"/>							<input type="radio"/>	<input type="radio"/>
	Self-diagnosis with CONSULT displays "CODE54".														<input type="radio"/>	<input type="radio"/>	<input type="radio"/>

Trouble diagnoses based on phenomena

CI  
 EC  
 AT  
 BR  
**ST**  
 RS  
 HA  
 EL  
 SD



# RESTRAINT SYSTEM

## SECTION **RS**

GI  
EC  
AT  
BR  
ST  
**RS**  
HA  
EL  
SD

## CONTENTS

<b>TROUBLE DIAGNOSES — Supplemental</b>			
<b>Restraint System (SRS)</b> .....	2		
Component Parts Location.....	2		
Precautions.....	2		
Circuit Diagram.....	2		
		Preliminary Check.....	3
		Trouble Diagnoses with CONSULT.....	3
		Trouble Diagnoses without CONSULT.....	5
		Symptom Chart.....	9
		Component Parts Inspection.....	10

Component Parts Location

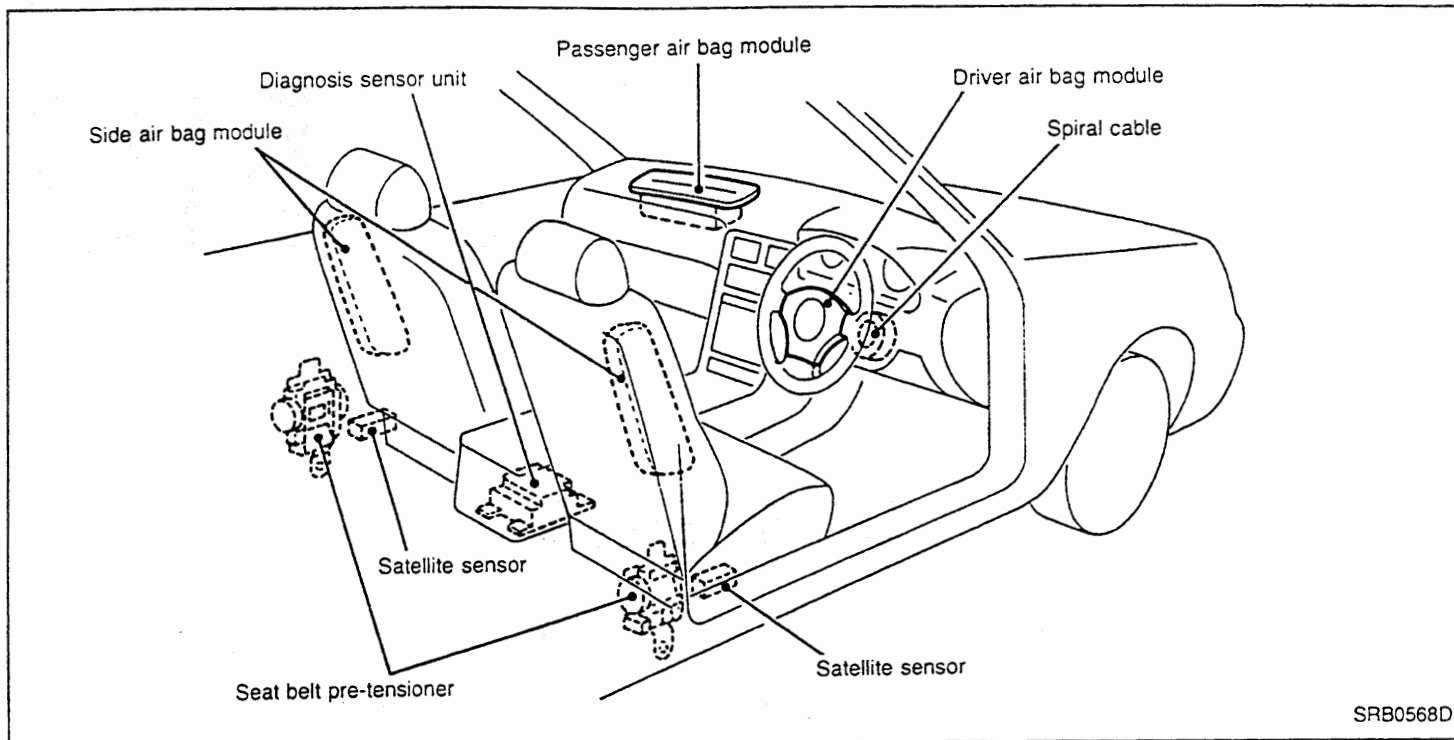

SRB0568D

Precautions

- To perform system diagnosis, use self-diagnosis function and CONSULT.
- Do not use electrical test equipment such as a circuit tester because any wrong operation caused by a weak electric current of a tester must be prevented.

Circuit Diagram

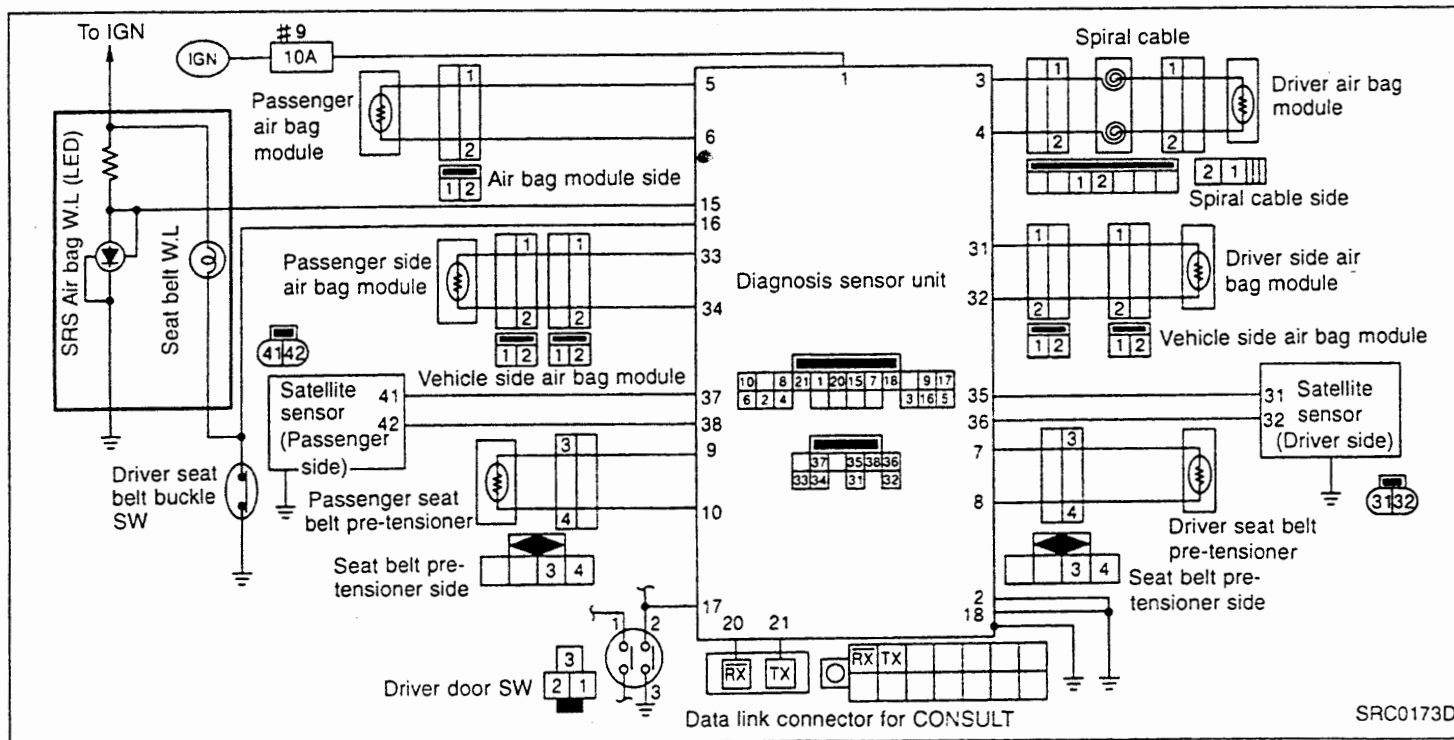

SRC0173D

## Preliminary Check

- Check battery voltage and specific gravity.
- When battery voltage drops to less than approx. 9V, the “AIR BAG” warning lamp starts flashing (indicating a malfunction).
- Check the connections of component connectors.
- Check that the fuse is not blown.

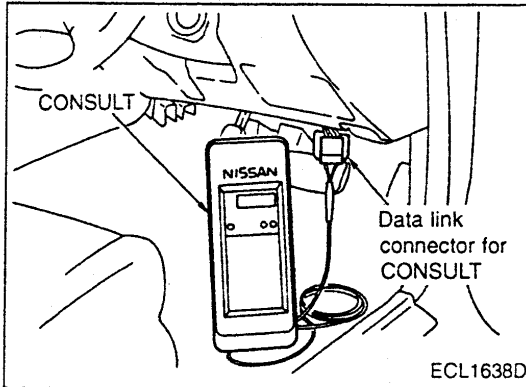

## Trouble Diagnoses with CONSULT

### SELF-DIAGNOSIS PROCEDURE

1. Connect CONSULT to data link connector on the vehicle.
  2. Turn ignition switch “ON”.
  3. Touch “AIR BAG” on the CONSULT screen.
  4. Touch an appropriate mode key on “SELECT DIAG MODE” screen.
  5. The self-diagnostic result for the selected mode is displayed.
  6. Repair or replace the malfunctioning part according to the self-diagnostic result.
  7. Touch “PRINT, if printout is required.
  8. After repairing the malfunction, touch “SELF-DIAG [CURRENT]”, and after checking that “NO SELF DIAGNOSTIC FAILURE INDICATED” is shown on the display, touch “ERASE”.
- For seat belt pre-tensioner system, the diagnostic procedure is completed when “NO SELF DIAGNOSTIC FAILURE INDICATED” is displayed.

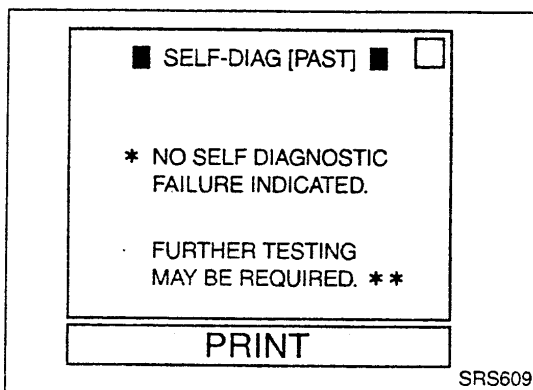
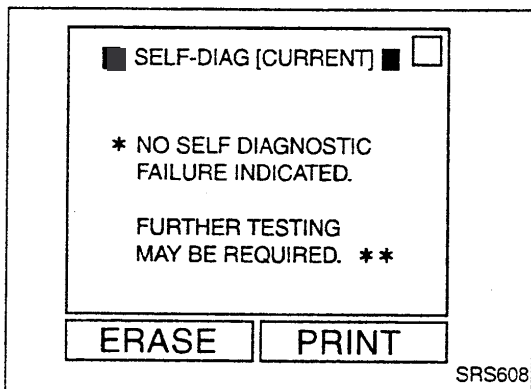

9. Return to “SELECT DIAG MODE” screen and touch “SELF-DIAG [PAST]”.
10. After checking that “NO SELF DIAGNOSTIC FAILURE INDICATED” is displayed on the “SELF-DIAG [PAST]” screen, finish the diagnosis.

# TROUBLE DIAGNOSES — Supplemental Restraint System (SRS)

## Trouble Diagnoses with CONSULT (Cont'd)

### SELF-DIAGNOSTIC CODE CHART

Diagnostic item	Explanation	Repair order
NO SELF-DIAGNOSTIC FAILURE INDICATED	No malfunction is detected.	—
AIRBAG MODULE [OPEN]	● Driver air bag module circuit is open (including the spiral cable).	<ol style="list-style-type: none"> <li>1. Visually check the wiring harness connection.</li> <li>2. Check continuity of the spiral cable.</li> <li>3. Replace driver air bag module.</li> <li>4. Replace the diagnosis sensor unit.</li> <li>5. Replace the harness if it has visible damage.</li> </ol>
AIRBAG MODULE [VB-SHORT]	● Driver air bag module circuit is shorted to some power supply circuit (including the spiral cable).	
AIRBAG MODULE [GND-SHORT]	● Driver air bag module circuit is shorted to ground (including the spiral cable).	
AIRBAG MODULE [SHORT]	● Driver air bag module circuits are shorted to each other (including the spiral cable).	
CONTROL UNIT	● Diagnosis sensor unit is malfunctioning.	<ol style="list-style-type: none"> <li>1. Visually check the diagnosis sensor unit connection.</li> <li>2. Replace the diagnosis sensor unit.</li> </ol>
ASSIST A/B MODULE [OPEN]	● Passenger air bag circuit is open.	<ol style="list-style-type: none"> <li>1. Visually check the wiring harness connection.</li> <li>2. Replace passenger air bag module.</li> <li>3. Replace the diagnosis sensor unit.</li> <li>4. Replace the harness if it has visible damage.</li> </ol>
ASSIST A/B MODULE [VB-SHORT]	● Passenger air bag circuit is shorted to some power supply circuit.	
ASSIST A/B MODULE [GND-SHORT]	● Passenger air bag circuit is shorted to ground.	
ASSIST A/B MODULE [SHORT]	● Passenger air bag circuits are shorted to each other.	
SIDE MODULE RH [OPEN]	● Driver side air bag circuit is open.	<ol style="list-style-type: none"> <li>1. Visually check the wiring harness connection.</li> <li>2. Replace driver side air bag module.</li> <li>3. Replace the diagnosis sensor unit.</li> <li>4. Replace the harness if it has visible damage.</li> </ol>
SIDE MODULE RH [VB-SHORT]	● Driver side air bag circuit is shorted to some power supply circuit.	
SIDE MODULE RH [GND-SHORT]	● Driver side air bag circuit is shorted to ground.	
SIDE MODULE RH [SHORT]	● Driver side air bag circuits are shorted to each other.	
SIDE MODULE LH [OPEN]	● Passenger side air bag circuit is open.	<ol style="list-style-type: none"> <li>1. Visually check the wiring harness connection.</li> <li>2. Replace passenger side air bag module.</li> <li>3. Replace the diagnosis sensor unit.</li> <li>4. Replace the harness if it has visible damage.</li> </ol>
SIDE MODULE LH [VB-SHORT]	● Passenger side air bag circuit is shorted to some power supply circuit.	
SIDE MODULE LH [GND-SHORT]	● Passenger side air bag circuit is shorted to ground.	
SIDE MODULE LH [SHORT]	● Passenger side air bag circuits are shorted to each other.	
SATELLITE SENS RH [UNIT FAIL]	● Driver satellite sensor is malfunctioning.	<ol style="list-style-type: none"> <li>1. Visually check driver satellite sensor connection.</li> <li>2. Replace the driver satellite sensor.</li> <li>3. Replace the harness if it has visible damage.</li> </ol>
SATELLITE SENS RH [COMM FAIL]	<ul style="list-style-type: none"> <li>● Driver satellite sensor is malfunctioning.</li> <li>● Diagnosis sensor unit is malfunctioning.</li> <li>● Wiring harness between diagnosis sensor unit and satellite sensor is damaged.</li> </ul>	<ol style="list-style-type: none"> <li>1. Visually check driver satellite sensor connection.</li> <li>2. Replace the driver satellite sensor.</li> <li>3. Replace the diagnosis sensor unit.</li> <li>4. Replace the harness if it has visible damage.</li> </ol>
SATELLITE SENS LH [UNIT FAIL]	● Passenger satellite sensor is malfunctioning.	<ol style="list-style-type: none"> <li>1. Visually check the connection of passenger satellite sensor.</li> <li>2. Replace the passenger satellite sensor.</li> <li>3. Replace the harness if it has visible damage.</li> </ol>
SATELLITE SENS LH [COMM FAIL]	<ul style="list-style-type: none"> <li>● Passenger satellite sensor is malfunctioning.</li> <li>● Diagnosis sensor unit is malfunctioning.</li> <li>● Wiring harness between diagnosis sensor unit and satellite sensor is damaged.</li> </ul>	<ol style="list-style-type: none"> <li>1. Visually check the connection of passenger satellite sensor.</li> <li>2. Replace the passenger satellite sensor.</li> <li>3. Replace the diagnosis sensor unit.</li> <li>4. Replace the harness if it has visible damage.</li> </ol>
DRIVE PRE-TENSIONER [OPEN/VB-SHORT]	● The circuit for the driver seat belt pre-tensioner is open or shorted to some power supply circuit.	<ol style="list-style-type: none"> <li>1. Visually check the wiring harness connection.</li> <li>2. Replace driver seat belt pre-tensioner.</li> <li>3. Replace the diagnosis sensor unit.</li> <li>4. Replace the harness if it has visible damage.</li> </ol>
DRIVE PRE-TENSIONER [GND-SHORT]	● The circuit for the driver seat belt pre-tensioner is shorted to ground.	
ASSIST PRE-TENSIONER [OPEN/VB-SHORT]	● The circuit for the passenger seat belt pre-tensioner is open or shorted to some power supply circuit.	<ol style="list-style-type: none"> <li>1. Visually check the wiring harness connection.</li> <li>2. Replace passenger seat belt pre-tensioner.</li> <li>3. Replace the diagnosis sensor unit.</li> <li>4. Replace the harness if it has visible damage.</li> </ol>
ASSIST PRE-TENSIONER [GND-SHORT]	● The circuit for the passenger seat belt pre-tensioner is shorted to ground.	

- The screens for "SELF-DIAG [CURRENT]", "SELF-DIAG [PAST]" and "TROUBLE DIAG RECORD" share the same message.
- Follow the repair procedures in numerical order. Check whether a malfunction is eliminated each time a repair item is finished, and when the malfunction is eliminated, further repair work is not required.
- After repairing the system, touch "ERASE" to clear the memory and check with CONSULT again.
- If both seat belt pre-tensioner systems on the driver seat and passenger seat have failed at the same time, only one of the two failures is displayed first. The other failure is displayed after the first failure is repaired. For seat belt pre-tensioner systems, only "SELF-DIAG [CURRENT]" is displayed; "SELF-DIAG [PAST]" and "TROUBLE DIAG RECORD" are not displayed.

# TROUBLE DIAGNOSES — Supplemental Restraint System (SRS)

## Trouble Diagnoses with CONSULT (Cont'd)

### TROUBLE DIAGNOSIS RECORD

If a malfunction has occurred but is not recorded on self-diagnosis, it may be caused by some past malfunction. In such a case, past malfunctions can be found by selecting "TROUBLE DIAG RECORD" in Diagnosis mode.

The "TROUBLE DIAG RECORD" can be selected for SRS air bag system only.

## Trouble Diagnoses without CONSULT

### SRS AIR BAG SYSTEM

#### Self-diagnosis

- The diagnosis modes are User mode and Diagnosis mode.
- Switching between the two modes is accomplished by using ignition switch and driver door switch.

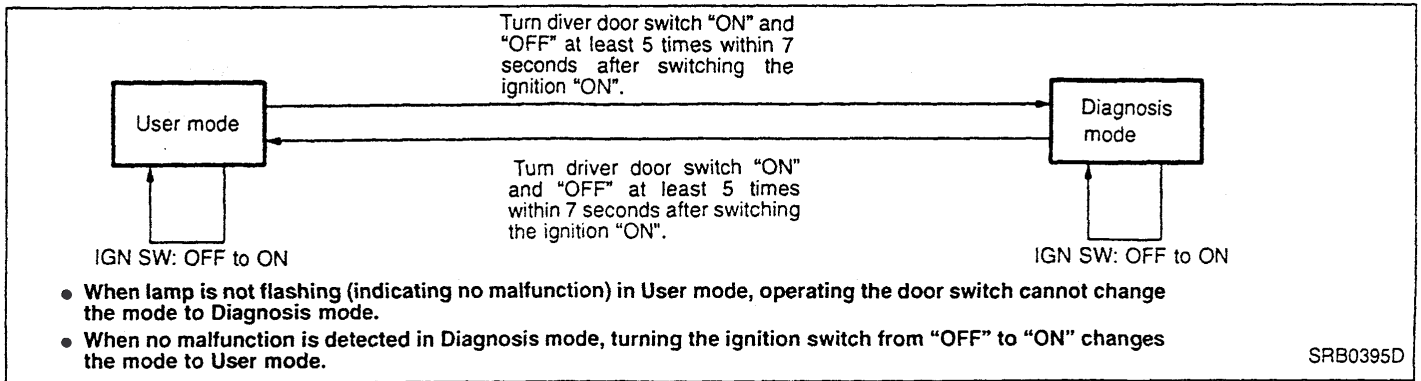

#### User mode

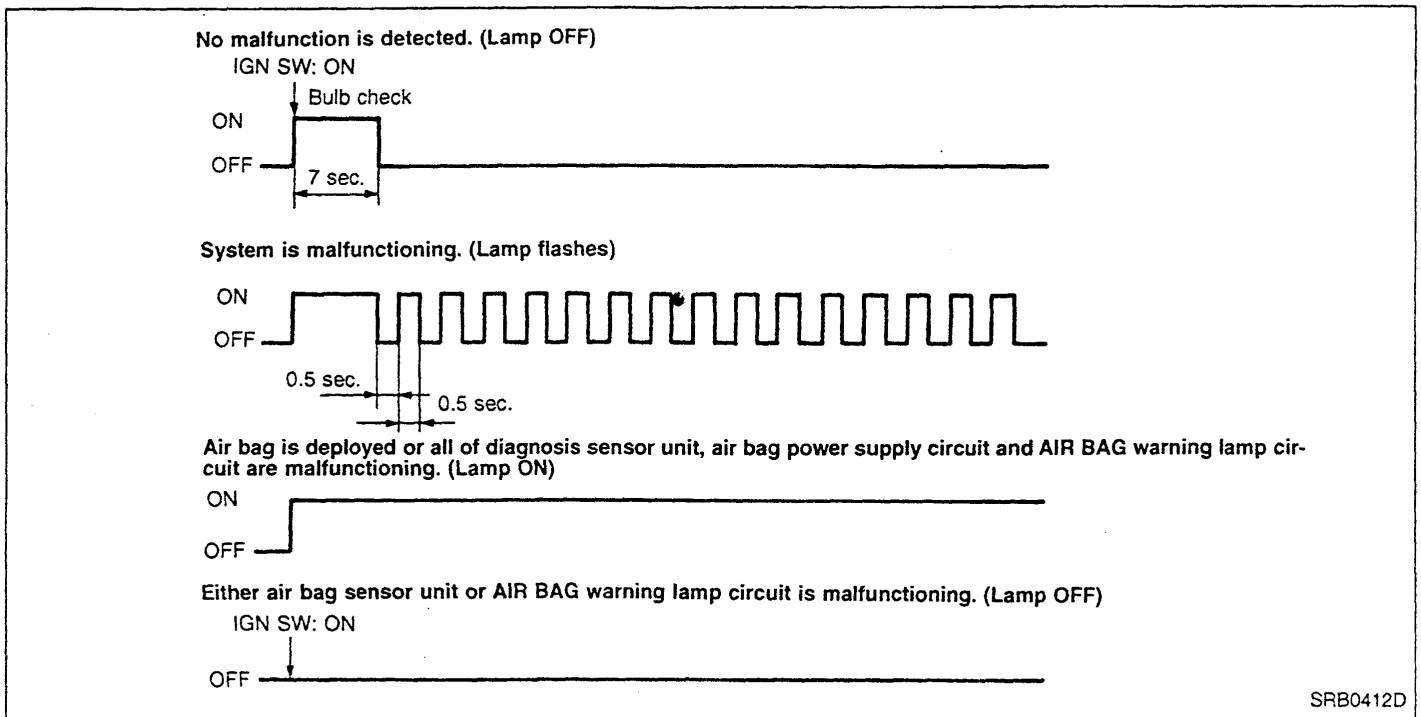

The display indicating a malfunction (flashes) keeps operation until reset. If, however, the malfunction is a low battery voltage (less than 9V), the display changes from flashing to normal operation when the battery voltage has returned to normal (more than 9V).

# TROUBLE DIAGNOSES — Supplemental Restraint System (SRS)

## Trouble Diagnoses without CONSULT (Cont'd)

### Diagnosis mode

Malfunctioning part	Diagnostic item	Warning lamp flash pattern
—	No malfunction is detected.	<p>IGN SW: ON ON (LED check)</p> <p style="text-align: right;">Unit: sec.</p>
Driver air bag module	Open circuit	<p>Two flashes</p> <p style="text-align: right;">Unit: sec.</p>
	Shorted to power supply circuit	
	Shorted to ground	
	Short-circuit between wires	
Diagnosis sensor unit	Unit malfunction	<p>Seven flashes</p> <p style="text-align: right;">Unit: sec.</p>
Passenger air bag module	Open circuit	<p>Eight flashes</p> <p style="text-align: right;">Unit: sec.</p>
	Shorted to power supply circuit	
	Shorted to ground	
	Short-circuit between wires	
Driver side air bag	Open circuit	<p>One flash</p> <p style="text-align: right;">Unit: sec.</p>
	Shorted to power supply circuit	
	Shorted to ground	
	Short-circuit between wires	
Passenger side air bag	Open circuit	<p>Two flashes</p> <p style="text-align: right;">Unit: sec.</p>
	Shorted to power supply circuit	
	Shorted to ground	
	Short-circuit between wires	
Driver satellite sensor	Satellite sensor malfunction	<p>Three flashes</p> <p style="text-align: right;">Unit: sec.</p>
	Open circuit	
	Shorted to power supply circuit	
	Shorted to ground	
	Short-circuit between wires	
	Diagnosis sensor unit malfunction	
Passenger satellite sensor	Satellite sensor malfunction	<p>Four flashes</p> <p style="text-align: right;">Unit: sec.</p>
	Open circuit	
	Shorted to power supply circuit	
	Shorted to ground	
	Short-circuit between wires	
	Diagnosis sensor unit malfunction	

SRB0463D

**After repairing the system, touch "ERASE" to clear (reset) the memory and check that no malfunction is shown on the display after turning on the ignition switch.**

# TROUBLE DIAGNOSES — Supplemental Restraint System (SRS)

## Trouble Diagnoses without CONSULT (Cont'd)

Ⓐ Flash pattern when no malfunction is detected

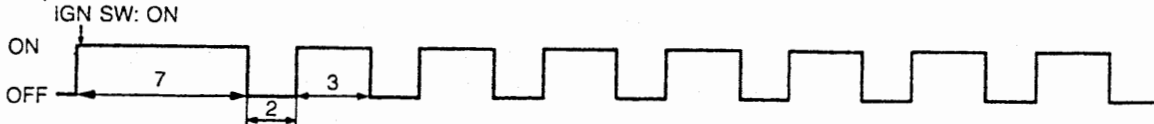

Ⓑ Flash pattern when one unit (driver air bag module) is malfunctioning

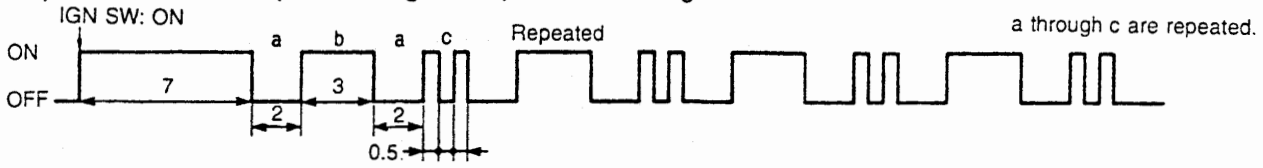

Ⓒ Flash pattern when two units (driver air bag module and diagnosis sensor unit) are malfunctioning

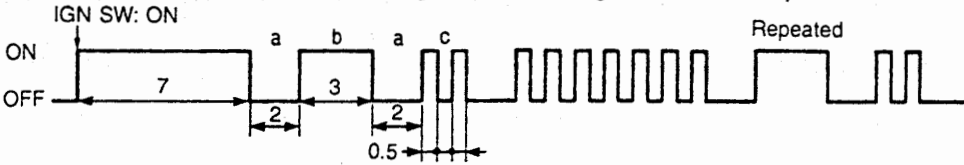

Ⓓ Flash pattern when one unit (driver side air bag module) is malfunctioning

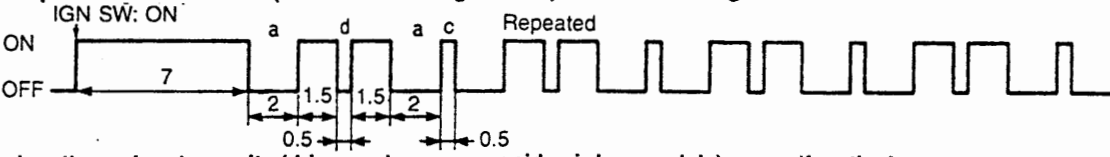

Ⓔ Flash pattern when two units (driver and passenger side air bag module) are malfunctioning

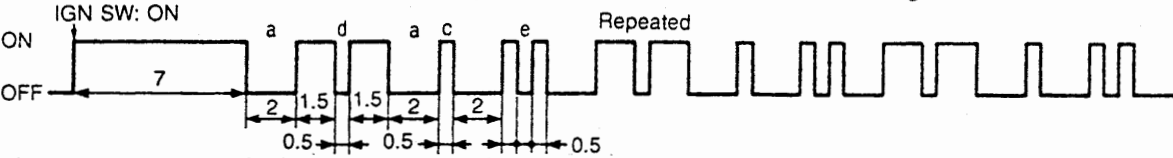

Ⓕ Flash pattern when two units (driver air bag and side air bag module) are malfunctioning

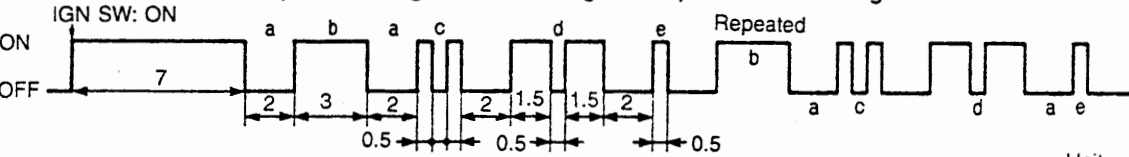

Unit: seconds

SRB0383D

GI  
EC  
AT  
BR  
ST  
RS  
HA  
EL  
SD

# TROUBLE DIAGNOSES — Supplemental Restraint System (SRS)

## Trouble Diagnoses without CONSULT (Cont'd)

### How to erase self-diagnostic results (Reset)

After repairing the system and while staying in Diagnosis mode, check that the system has returned to normal; then, turn the ignition switch "OFF" and then back "ON". The mode returns to User mode and the diagnosis record is erased.

## SEAT BELT PRE-TENSIONER SYSTEM

### Self-diagnosis

Only User mode is available.

### User mode

Driver seat belt (Seat belt buckle switch)	Warning lamp flash pattern	Malfunctioning part	Diagnostic item
Fastened (OFF)		—	No malfunction is detected.
Unfastened (ON)		—	No malfunction is detected.
Fastened (OFF)		<ul style="list-style-type: none"> <li>● Driver and passenger seat belt pre-tensioner circuits</li> <li>● Diagnosis sensor unit</li> </ul>	<ul style="list-style-type: none"> <li>● Shorted to power supply circuit</li> <li>● Open circuit</li> <li>● Shorted to ground</li> <li>● Diagnosis sensor unit malfunction</li> </ul>
Unfastened (ON)			

SFB0439D

- The display indicating a malfunction (flashes) changes to the display indicating no malfunction when the malfunction is repaired.
- After pre-tensioner is activated, the warning lamp stays "ON".



## Symptom Chart

Trouble phenomenon	Malfunctioning unit	Possible cause
AIR BAG warning lamp does not turn on. (All other warning lamps turn on.)	AIR BAG warning lamp circuit	<ul style="list-style-type: none"> <li>● Warning lamp and internal circuit of combination meter are faulty.</li> <li>● Harness between diagnosis sensor unit and combination meter is faulty (shorted).</li> </ul>
	Diagnosis sensor unit	<ul style="list-style-type: none"> <li>● Diagnosis sensor unit is faulty.</li> </ul>
AIR BAG warning lamp does not turn off (always ON).	Air bag power supply circuit	<ul style="list-style-type: none"> <li>● Air bag power fuse has blown.</li> <li>● Air bag power harness is faulty.</li> </ul>
	AIR BAG warning lamp circuit	<ul style="list-style-type: none"> <li>● Harness between diagnosis sensor unit and combination meter is faulty (open).</li> <li>● Internal circuit of combination meter is faulty.</li> </ul>
	Diagnosis sensor unit	<ul style="list-style-type: none"> <li>● Diagnosis sensor unit is faulty.</li> </ul>
AIR BAG warning lamp flashes.	<ul style="list-style-type: none"> <li>● Low battery voltage (Less than 9V)</li> <li>● Conduct either diagnosis with CONSULT (self-diagnosis, trouble diagnosis record) or diagnosis without CONSULT (self-diagnosis), and repair the malfunctioning part.</li> <li>● After repairing the malfunctioning part, erase the memory for malfunction record.</li> </ul>	
When driver seat belt is fastened (buckle switch is off) and ignition switch is turned on, the SEAT BELT warning lamp does not illuminate for 7 seconds. (All other warning lamps illuminate.)	SEAT BELT warning lamp circuit	<ul style="list-style-type: none"> <li>● Warning lamp and internal circuit of combination meter are faulty.</li> <li>● Harness between diagnosis sensor unit and combination meter is faulty (open).</li> </ul>
	Air bag power supply circuit	<ul style="list-style-type: none"> <li>● Air bag power fuse has blown.</li> <li>● Air bag power harness is faulty.</li> </ul>
	Diagnosis sensor unit	<ul style="list-style-type: none"> <li>● Diagnosis sensor unit is faulty.</li> </ul>
When driver seat belt is fastened (buckle switch is off) and ignition switch is turned on, the SEAT BELT warning lamp does not turn off 7 seconds later.	SEAT BELT warning lamp circuit	<ul style="list-style-type: none"> <li>● Harness between diagnosis sensor unit and combination meter is faulty (shorted).</li> </ul>
	Driver seat belt buckle switch circuit	<ul style="list-style-type: none"> <li>● Harness between combination meter and driver seat belt buckle switch is faulty (shorted).</li> <li>● Driver seat belt buckle switch is faulty (sticking).</li> </ul>
	Diagnosis sensor unit	<ul style="list-style-type: none"> <li>● Diagnosis sensor unit is faulty.</li> </ul>
When driver seat belt is fastened (buckle switch is off) and ignition switch is turned on, the SEAT BELT warning lamp turns on, and 7 seconds later, flashes.	Seat belt pre-tensioner circuit	<ul style="list-style-type: none"> <li>● Conduct either diagnosis with CONSULT or diagnosis without CONSULT, and repair the malfunctioning part.</li> </ul>
When driver seat belt is not fastened (buckle switch is on) and ignition switch is turned on, the SEAT BELT warning lamp turns off about 7 seconds later.	Driver seat belt buckle switch circuit	<ul style="list-style-type: none"> <li>● Driver seat belt buckle switch ground harness is faulty (open).</li> <li>● Driver seat belt buckle switch is faulty (contact intermittence).</li> </ul>

If the flashing of AIR BAG warning lamp is caused by low battery voltage, self-diagnosis mode cannot be switched from User mode to Diagnosis mode. In this case, diagnosis with CONSULT displays "NO SELF-DIAGNOSTIC FAILURE INDICATED".

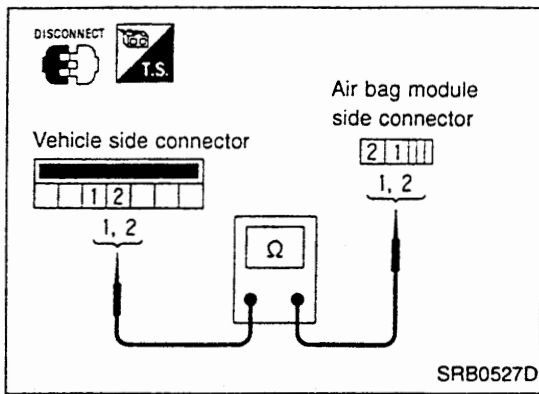

## Component Parts Inspection

### SPIRAL CABLE

- Disconnect the spiral cable connectors from air bag module and air bag sensor unit.
- Check continuity between terminals.  
**1 - 1, 2 - 2: Continuity should exist.**

# HEATER & AIR CONDITIONER

## SECTION **HA**

GI

EC

AT

BR

ST

RS

**HA**

EL

SD

## CONTENTS

<b>COOLER CYCLE</b> .....	2	Performance Test.....	8
Deodorizing Clean Filter.....	2	Trouble Diagnosis by Gauge Pressure.....	10
<b>FULLY AUTOMATIC AIR CONDITIONER</b> .....	3	Trouble Diagnosis by Self-diagnosis Function.....	11
System Description.....	3	Magnet Clutch System Check.....	15
Component Parts Location.....	4	Blower Fan Motor System Check.....	15
Circuit Diagram.....	5	Actuator System Check.....	16
Automatic Amplifier Input /Output Signal		Trouble Diagnosis for Each Symptom.....	17
Specifications.....	6	Component Parts Inspection.....	18

# COOLER CYCLE

## Deodorizing Clean Filter

### REMOVAL

1. Remove the instrument lower assist panel.
2. Remove the clip, and remove the cover.
3. Remove the deodorizing clean filter assembly from the blower and cooling unit.

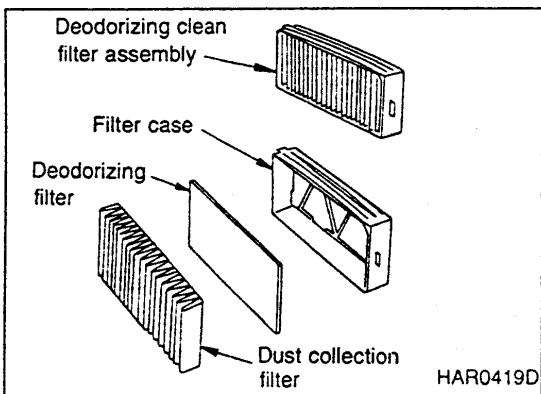
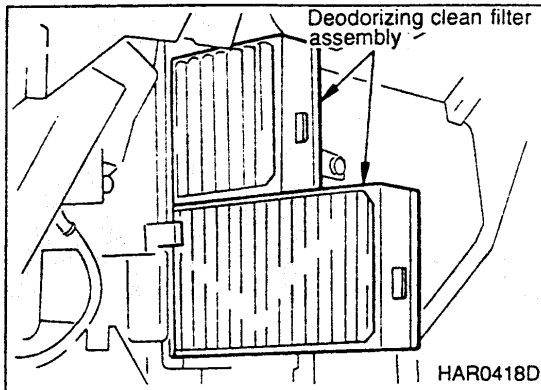

### REPLACEMENT

**Replacement period for deodorizing clean filter: Every year or every 12,000 km**

Write the necessary information on the label, and stick it in the glove box location indicated in the left figure.

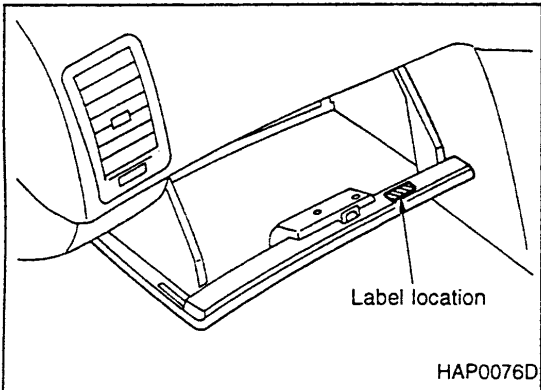

## System Description

- The fully automatic air conditioner system utilizes sensors to detect the in-vehicle temperature, ambient temperature, temperature of air passing through the evaporator, and sunload. The detected values are compared with the temperature adjustment dial setting, and calculated by the microcomputer within the automatic amplifier. The air inlet and outlet temperatures and airflow rate are adjusted in order to maintain the in-vehicle temperature. GI
- When an abnormal pressure occurs within the cooler cycle [gauge pressure: approx. 2.7 MPa (28 kg/cm<sup>2</sup>·G) or higher; or approx. 0.18 MPa (1.8 kg/cm<sup>2</sup>·G) or lower] the refrigerant pressure sensor operates, and stops the compressor. EC
- The ECM turns off the air conditioner relay, and stops the compressor during engine high load.
- The blower fan motor utilizes a brushless motor, and controls the airflow with a built-in IC that recognizes the driver signal (pulse) from the automatic amplifier. AT
- Step-motor type actuators are employed for intake door, mode door, and air mix door. They are rotated in response to the signal (pulse) step quantity transmitted from the automatic amplifier to control the target door position. BR

GI

EC

AT

BR

ST

RS

HA

EL

SD

# FULLY AUTOMATIC AIR CONDITIONER

## Component Parts Location

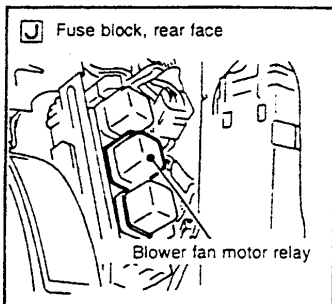
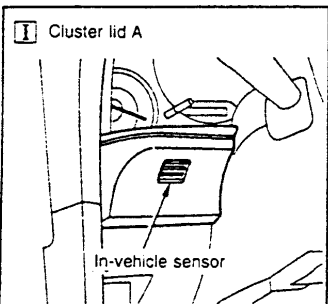
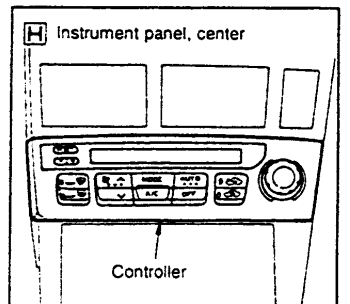
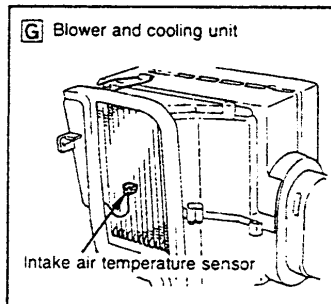
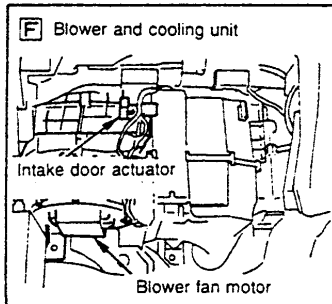
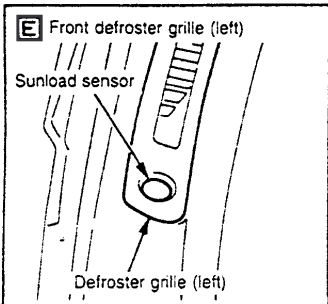
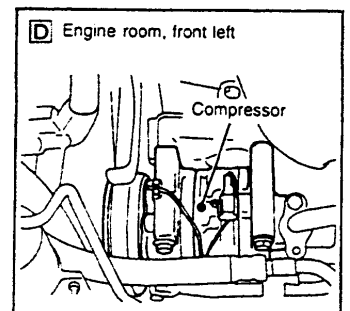
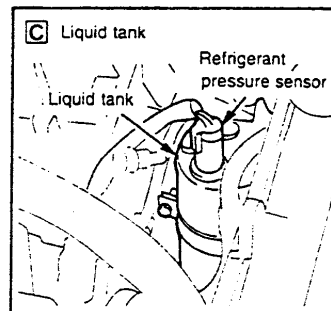
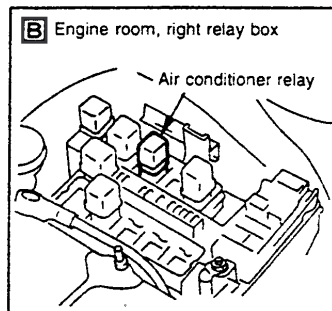
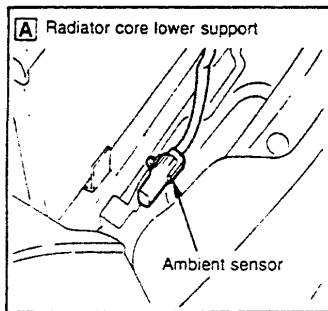
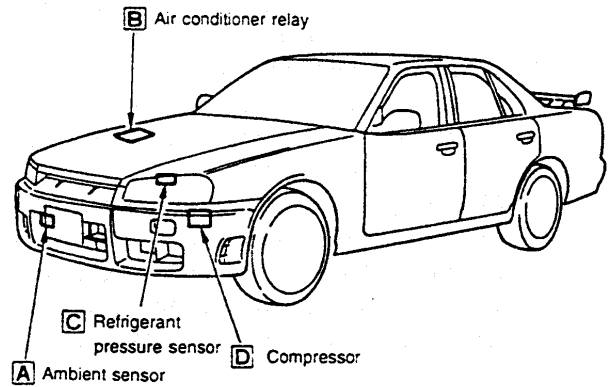
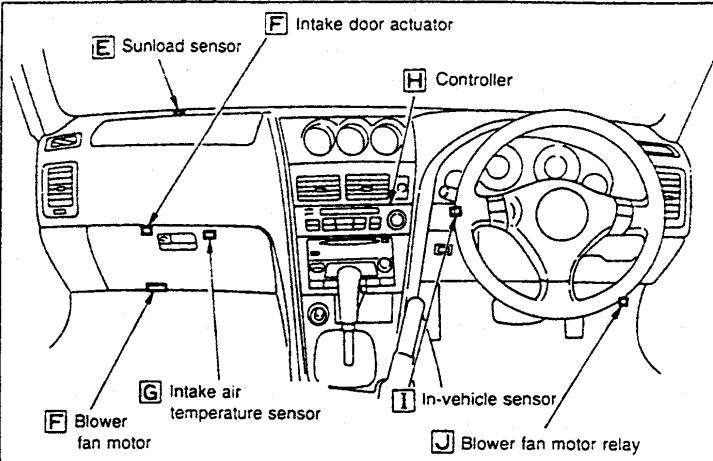

# FULLY AUTOMATIC AIR CONDITIONER

## Circuit Diagram

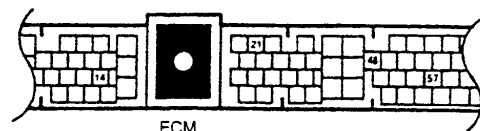
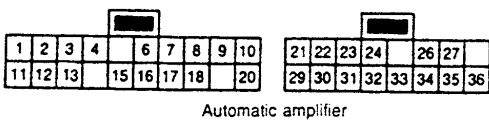
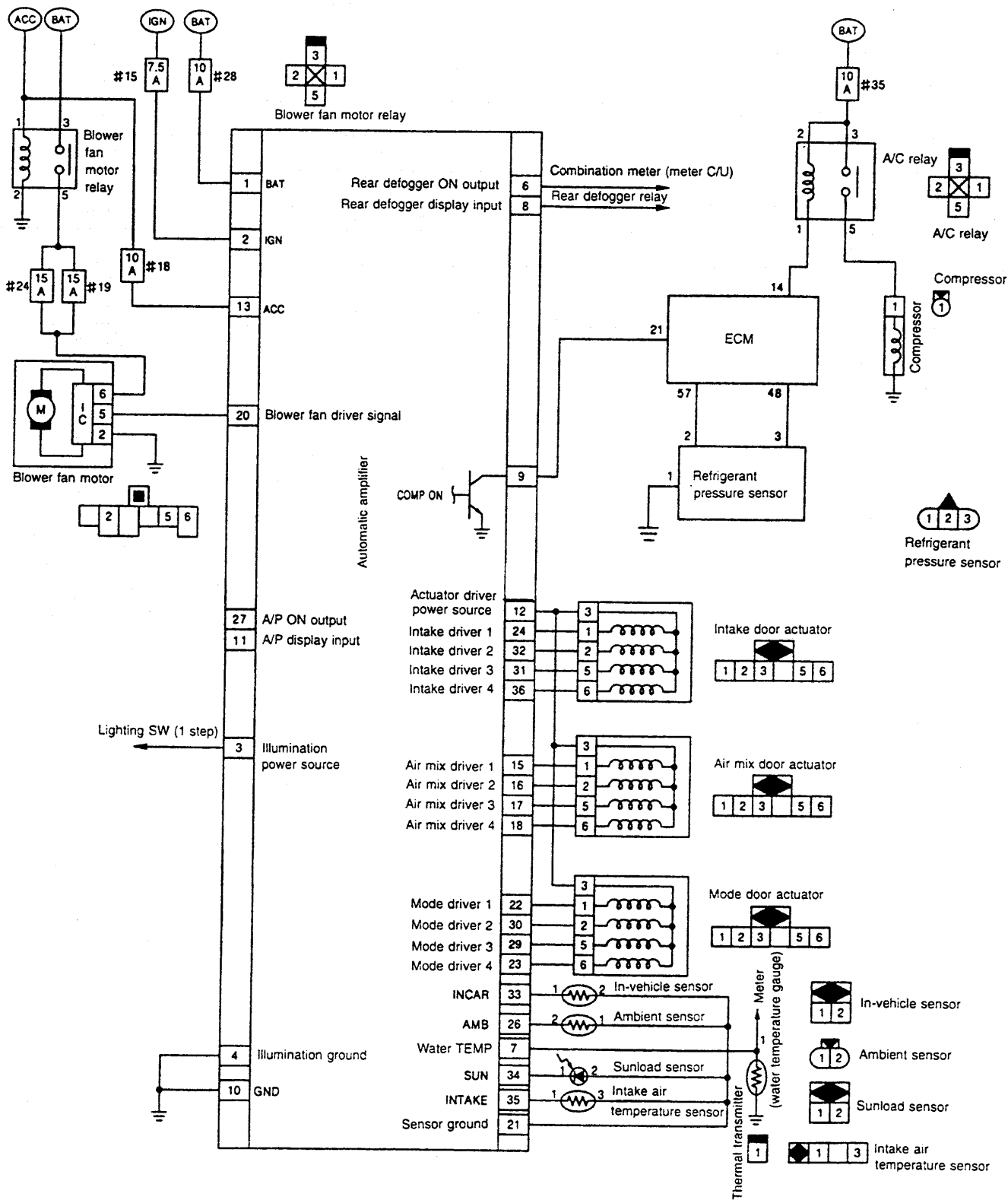

# FULLY AUTOMATIC AIR CONDITIONER

## Automatic Amplifier Input /Output Signal Specifications

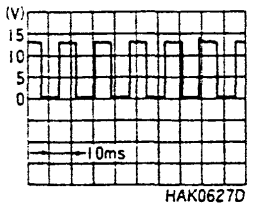
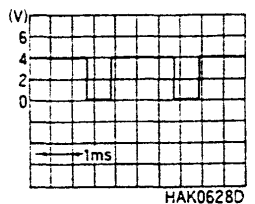
Terminal No.	Signal name	Measurement condition		Specification V
		Ignition switch	Operation or condition	
1	Battery power source	OFF	—	Approx. 12
2	Ignition power source	ON	—	Approx. 12
3	Illumination	—	Lighting switch: 1 step	Approx. 12
4	Illumination ground	ON	Lighting switch: 1 step	Approx. 0
6	Rear defogger ON output signal	ON	Rear defogger switch: ON Rear defogger switch: OFF	Approx. 0 Approx. 5
7	Thermal transmitter	—	—	*
8	Rear defogger display input signal	ON	Rear defogger switch: ON Rear defogger switch: OFF	Approx. 12 Approx. 0
9	Compressor ON signal	ON	Compressor: ON Compressor: OFF	Approx. 0 Approx. 5
10	Ground	ON	—	Approx. 0
11	A/P display output signal (only when connected)	ON	Blower fan motor: ON Blower fan motor: OFF	Approx. 0 Approx. 5
12	Actuator driver power source	ON	—	Approx. 12
13	ACC power source	ACC	—	Approx. 12
15	Air mix door actuator driver signal	ON	Right after temperature adjustment dial operation	
16				
17				
18				
20	Fan control signal	ON	Fan speed: Manual 1st	
21	Sensor ground	ON	—	Approx. 0

\*: Refer to "Component Parts Inspection".



# FULLY AUTOMATIC AIR CONDITIONER

## Automatic Amplifier Input /Output Signal Specifications (Cont'd)

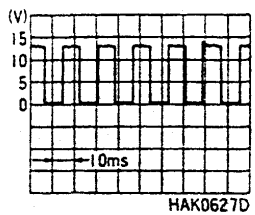
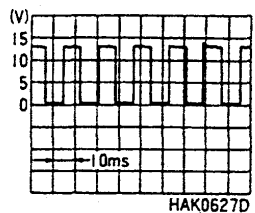
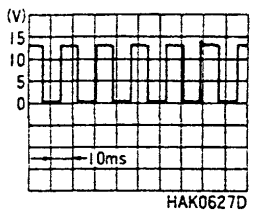
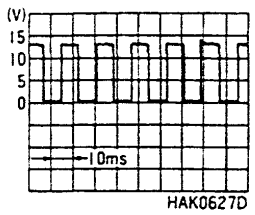
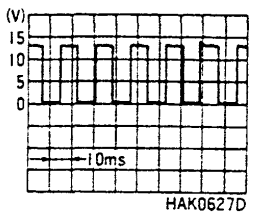
Terminal No.	Signal name	Measurement condition		Specification V
		Ignition switch	Operation or condition	
22 23	Mode door actuator driver signal	ON	Right after mode switch (air outlet switch) operation	
24	Intake door actuator driver signal	ON	Right after FRE switch or REC switch operation	
26	Ambient sensor	—	—	*
27	A/P ON output (only when connected)	ON	Blower fan motor: ON Blower fan motor: OFF	Approx. 0 Approx. 5
29 30	Mode door actuator driver signal	ON	Right after mode switch (air outlet switch) operation	
31 32	Intake door actuator driver signal	ON	Right after FRE switch or REC switch operation	
33	In-vehicle sensor	—	—	*
34	Sunload sensor	—	—	*
35	Intake air temperature sensor	—	—	*
36	Intake door actuator driver signal	ON	Right after FRE switch or REC switch operation	

\*: Refer to "Component Parts Inspection".

GI  
EC  
AT  
BR  
ST  
RS  
HA  
EL  
SD

## Performance Test

### PROCEDURE

1. Connect the manifold gauge to the vehicle side cooler cycle (service valve).
2. Attach a psychrometer to the recirculation air inlet port of the blower and cooling unit (below the glove box); and attach a dry-bulb thermometer to the right side of the center ventilator grille.
3. Start and warm up the engine.
4. After warming up the engine, check that the engine speed has reached the standard idle speed.
5. After pressing the AUTO switch, operate the fan switch, mode switch (air outlet switch), REC switch, temperature adjustment dial and switch; and satisfy the following conditions.
  - Fan speed: 4th
  - Air inlet: Recirculation
  - Air outlet: Ventilator (VENT)
  - Temperature setting: 18°C
6. Completely open the hood and all door windows, and close all doors.
7. Maintain these conditions until the cooler cycle stabilizes. (Approx. 10 minutes)
8. Maintain the engine speed at idle.
9. Measure the recirculation inlet temperature and humidity, outlet temperature, and cooler cycle high- and low-pressures. Compare and judge the values with the "AMBIENT AIR TEMPERATURE AND PRESSURE CHARACTERISTICS" and "INTAKE AIR TEMPERATURE AND DISCHARGE AIR TEMPERATURE CHARACTERISTICS".

# FULLY AUTOMATIC AIR CONDITIONER

## Performance Test (Cont'd)

### INTAKE AIR TEMPERATURE AND DISCHARGE AIR TEMPERATURE CHARACTERISTICS

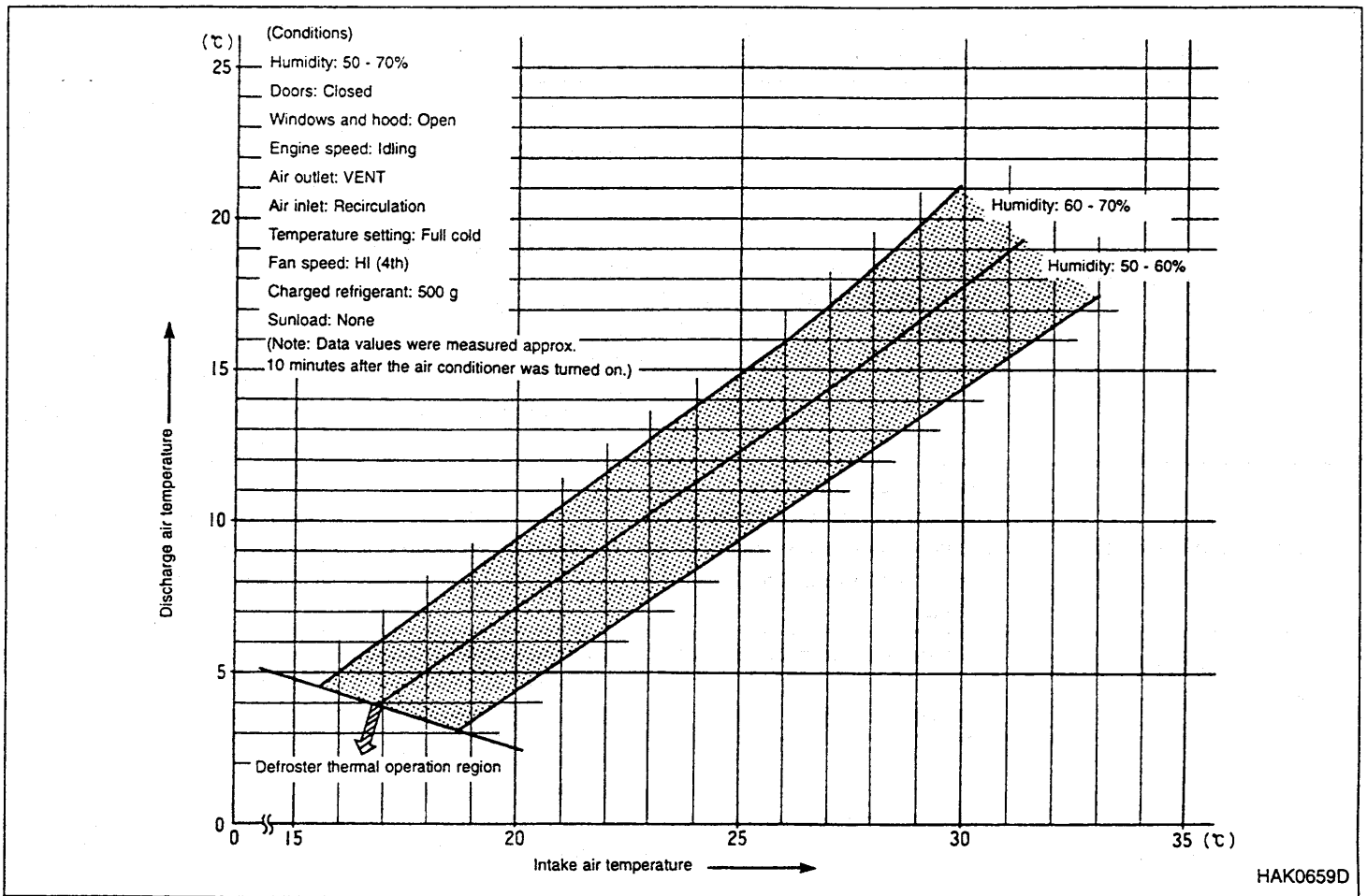

### AMBIENT AIR TEMPERATURE AND PRESSURE CHARACTERISTICS

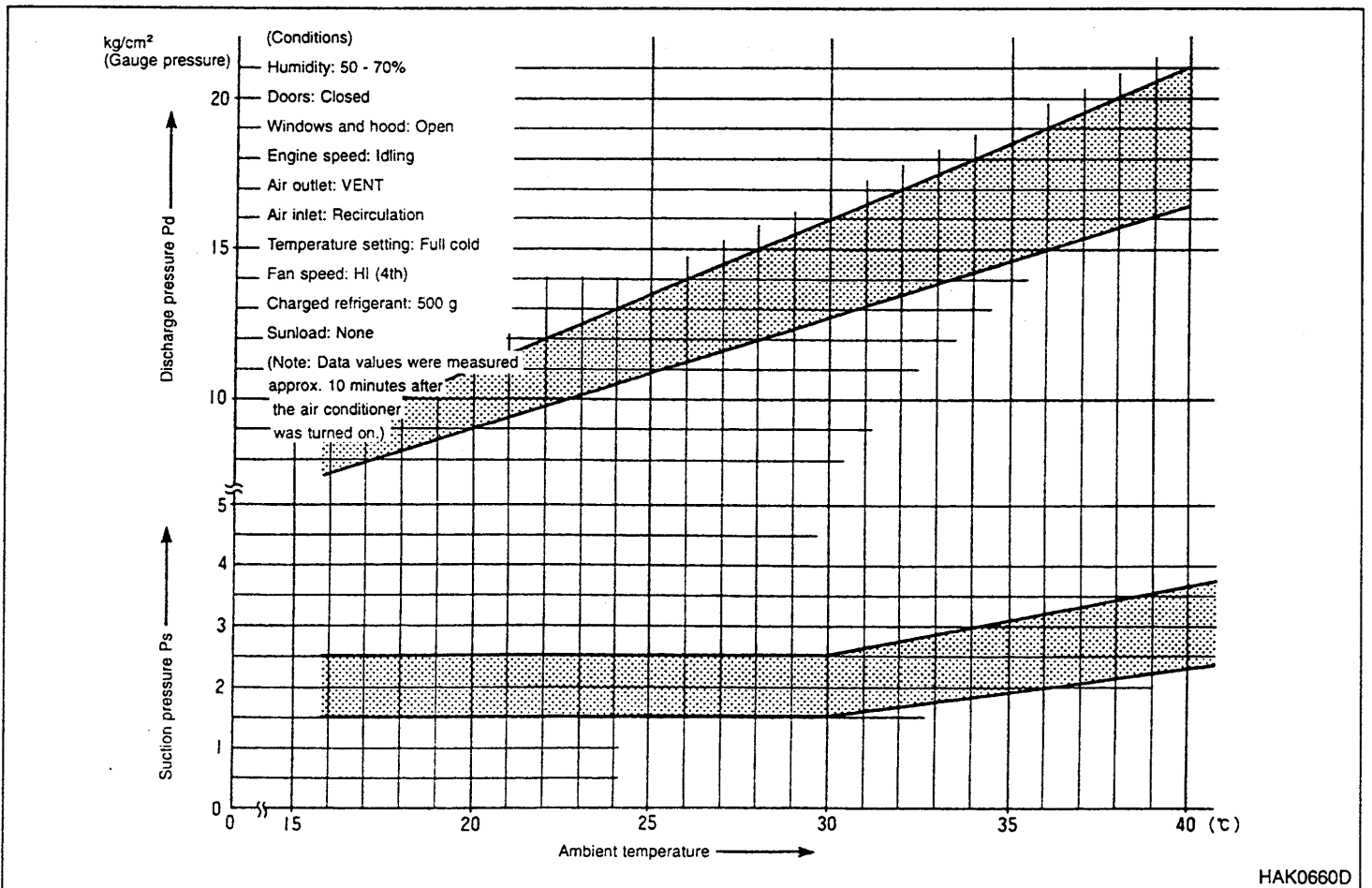

GI  
EC  
AT  
BR  
ST  
RS  
HA  
EL  
SD

# FULLY AUTOMATIC AIR CONDITIONER

## Trouble Diagnosis by Gauge Pressure

Connect the manifold gauge to the cooler cycle (service valve). Speculate and correct the root cause and trouble location based on the cooler cycle pressure.

Symptom	Cycle status	Probable cause	Corrective action
Both high- and low-pressures are high.	Pressure returns to normal when water is splashed on the condenser.	Insufficient cooling by condenser <ul style="list-style-type: none"> <li>● Radiator fan malfunction</li> <li>● Improper air guard attachment</li> <li>● Clogged or dirty condenser fins</li> </ul>	Repair or replace faulty parts. Clean or repair the condenser fins.
		Refrigerant over-charge	Recover all refrigerant. Re-vacuum and charge to appropriate amount.
High-pressure is too high.	When the compressor is stopped, the pressure drops suddenly approx. 2 kg/cm <sup>2</sup> . Then, the pressure drops gradually.	Air is mixed in the cooler cycle.	Recover all refrigerant. Re-vacuum and charge to appropriate amount.
High-pressure is high, and low-pressure is too low.	Temperature differences occurs where the high-pressure pipe is crushed or clogged.	Crushed or clogged high-pressure pipe between the compressor and condenser	Repair or replace faulty part.
Both high- and low-pressures are low. (Sometimes the low pressure is negative.)	Evaporator outlet is not cooled.	Clogged expansion valve <ul style="list-style-type: none"> <li>● Gas leak at temperature sensor</li> <li>● Clogging due to foreign matter</li> </ul>	Remove foreign matter in expansion valve, or replace.
	There is a temperature difference at the liquid tank outlet pipe, or liquid tank is covered with frost.	Liquid tank malfunction (clogged strainer)	Replace liquid tank.
	Evaporator outlet pipe is covered with frost (no airflow).	Improper attachment or failure of intake air temperature sensor thermistor	Replace intake air temperature sensor, or repair thermistor attachment position.
	There is some temperature difference between compressor high- and low-pressure pipes.	Insufficient refrigerant	Inspect for refrigerant leakage. Recover all refrigerant. Re-vacuum and charge to appropriate amount.
Sometimes high-pressure is low, and low-pressure is negative.	Sometimes, the evaporator outlet is not cooled. Sometimes, the evaporative inlet is covered with frost.	Moisture is mixed in the cooler cycle. (Clogging due to frozen moisture in the expansion valve)	Extract all refrigerant. Sufficiently vacuum and remove moisture. Charge to appropriate amount. At this time, replace the liquid tank without fail.
High-pressure is low, and low-pressure is high.	When the compressor is stopped, the pressures equalize. There is no temperature difference between the compressor high-pressure pipe and low-pressure pipe.	Compressor malfunction (compression defect) <ul style="list-style-type: none"> <li>● Valve damage or failure</li> <li>● Faulty gasket</li> </ul>	Replace the compressor.

## Trouble Diagnosis by Self-diagnosis Function

### DESCRIPTION

There are 5 steps in the self-diagnosis: to check for any sensor failure, and to check that a given control signal is transmitted to each output device.

	Step 1	Step 2	Step 3	Step 4	Step 5
Diagnosis content	Display segments and indicator lamp check	Each sensor check	Each actuator check and reset	Each output device check	Detected temperature display for each sensor
Diagnostic item	<ul style="list-style-type: none"> <li>● Display segments</li> <li>● Indicator lamp</li> </ul>	<ul style="list-style-type: none"> <li>● Ambient sensor</li> <li>● In-vehicle sensor</li> <li>● Intake air temperature sensor</li> <li>● Sunload sensor</li> </ul>	<ul style="list-style-type: none"> <li>● Intake door actuator</li> <li>● Air mix door actuator</li> <li>● Mode door actuator</li> </ul>	<ul style="list-style-type: none"> <li>● Intake door actuator</li> <li>● Air mix door actuator</li> <li>● Mode door actuator</li> <li>● Blower fan motor</li> <li>● Compressor</li> <li>● Air purifier (only when connected)</li> </ul>	<ul style="list-style-type: none"> <li>● Ambient sensor</li> <li>● In-vehicle sensor</li> <li>● Intake air temperature sensor</li> </ul>

### SELF-DIAGNOSIS OPERATION PROCEDURE

#### Switching to self-diagnosis mode

- Turn the temperature adjustment dial all the way to the left.
- Start the engine with the ignition switch from OFF position. Within 10 seconds, press and hold the OFF switch for more than approx. 5 seconds, to start the self-diagnosis step 1.

#### Self-diagnosis completion

- Turn the ignition switch OFF.
- Turn the AUTO switch ON.

#### Switching between self-diagnosis steps

- Use the temperature adjustment dial to switch between self-diagnosis steps 1 to 5.  
Temperature adjustment dial (turn clockwise): Step 1→5  
Temperature adjustment dial (turn counterclockwise): Step 5→1
- Refer to "SELF-DIAGNOSIS DISPLAY ITEM" for the diagnosis contents of each step.

GI

EC

AT

BR

ST

RS

HA

EL

SD

# FULLY AUTOMATIC AIR CONDITIONER

## Trouble Diagnosis by Self-diagnosis Function (Cont'd)

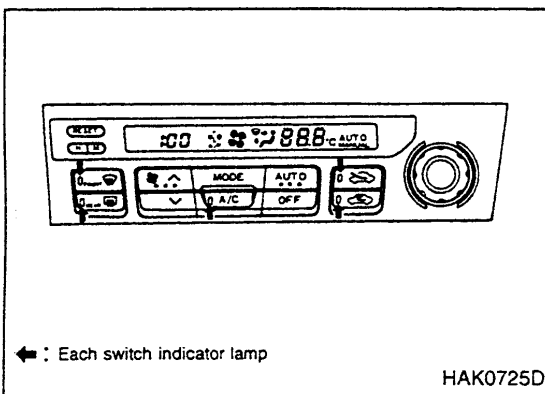
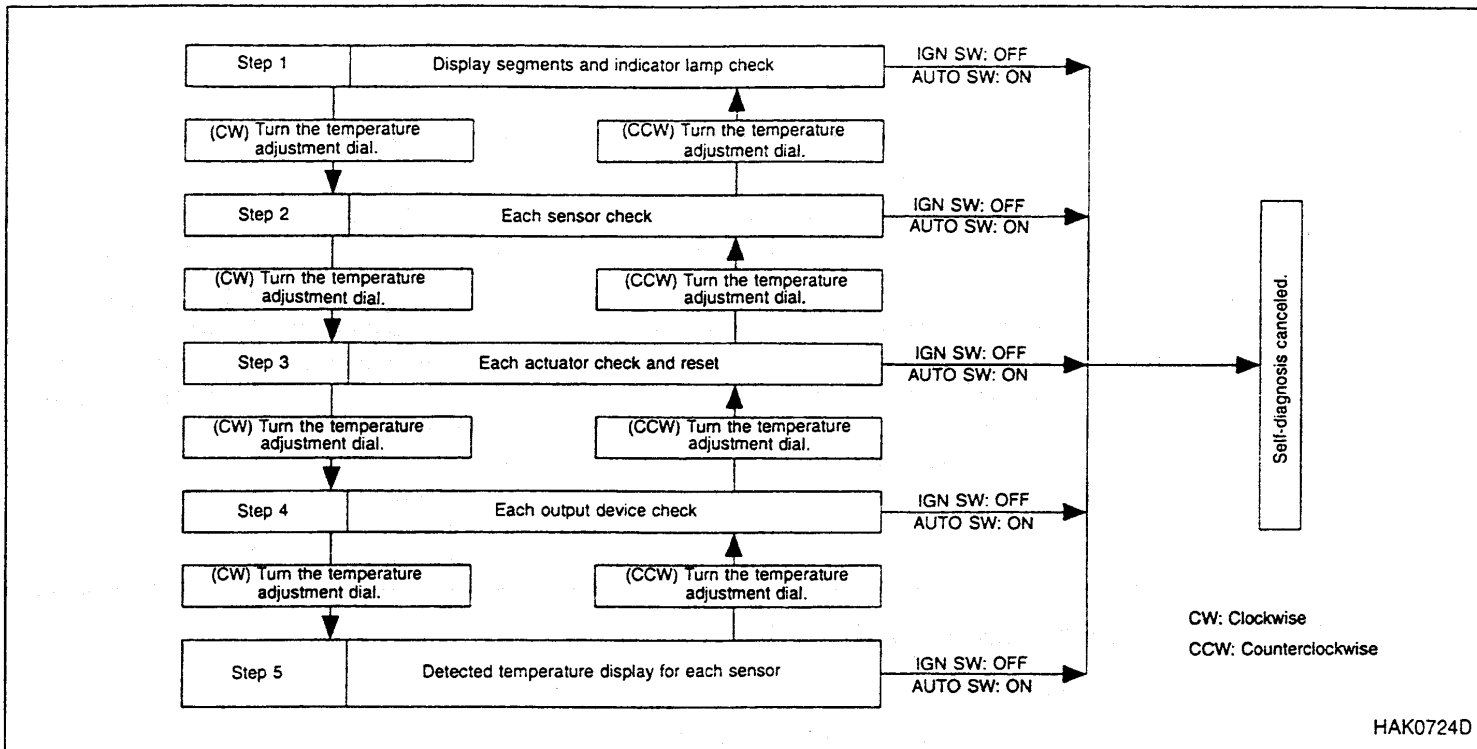

### SELF-DIAGNOSIS DISPLAY ITEM

#### Step 1 — Display segments and indicator lamp check

Check the controller switch indicator lamp and display segments.  
Normal: The switch indicator lamp and display segments are illuminated.

Abnormal: Malfunctioning area will not be illuminated.

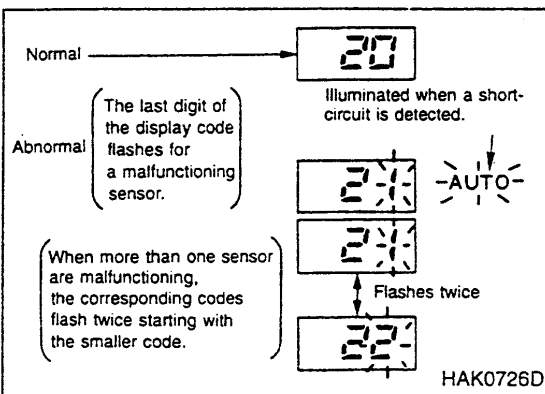

#### Step 2 — Each sensor check

Display shows "2" in the step 2 mode, and then shows the judgement result.

Check the data of each sensor inputted into the automatic amplifier.

Normal: Display shows "20".

Abnormal: The last digit of the display code flashes for a malfunctioning sensor. At this time, if a short-circuit is detected, "AUTO" is displayed. Furthermore, when there are more than one malfunctioning sensor, the corresponding display codes flash twice starting with the smaller code.

The sunload sensor will judge an abnormality when there is insufficient lighting (less than 5,000 lx) such as while being placed indoor or during the evening.

# FULLY AUTOMATIC AIR CONDITIONER

## Trouble Diagnosis by Self-diagnosis Function (Cont'd)

### Display code for malfunctioning sensor and identifying condition for automatic amplifier

Display code	Sensor	Identifying condition for automatic amplifier	
		Open circuit	Short-circuit
21	Ambient sensor	Less than -41.9°C	More than 100°C
22	In-vehicle sensor	Less than -41.9°C	More than 100°C
24	Intake air temperature sensor	Less than -41.9°C	More than 100°C
25	Sunload sensor	Less than 41.8 W/m <sup>2</sup> (36.0 kcal/m <sup>2</sup> ·h)	More than 1729 W/m <sup>2</sup> (1487 kcal/m <sup>2</sup> ·h)

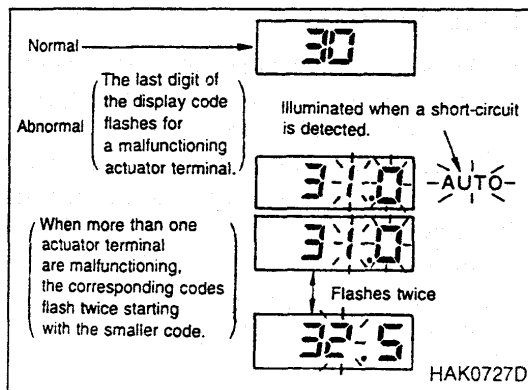

### Step 3 — Each actuator check and reset

Display shows "3" for approx. 1 second in the step 3 mode, and then shows the judgement result.

Transmit an output signal to the intake door actuator, mode door actuator, and air mix door actuator; and check each actuator. Furthermore, the actuator can be reset by pressing the front DEF switch at this time.

Normal: Display shows "30".

Abnormal: The display code flashes for a malfunctioning actuator.

At this time, if a short-circuit is detected, "AUTO" is displayed. Furthermore, when there are more than one malfunctioning sensor, the corresponding display codes flash twice starting with the smaller code.

During reset: Display flashes "30" and front DEF switch. (Approx. 10 seconds)

### Actuator display code

Display code	31.0 - 32.5	33.0 - 34.5	35.0 - 36.5
Actuator	Air mix door	Mode door	Intake door

### Faulty harness display

Actuator	Air mix door actuator				Mode door actuator				Intake door actuator			
	1	2	5	6	1	2	5	6	1	2	5	6
Terminal No. (actuator side)												
Terminal No. (automatic amplifier side)	15	16	17	18	22	30	29	23	24	32	31	36
Open or short-circuit failure display	31.0	31.5	32.0	32.5	33.0	33.5	34.0	34.5	35.0	35.5	36.0	36.5

\*: "AUTO" is displayed for a short-circuit.

# FULLY AUTOMATIC AIR CONDITIONER

## Trouble Diagnosis by Self-diagnosis Function (Cont'd)

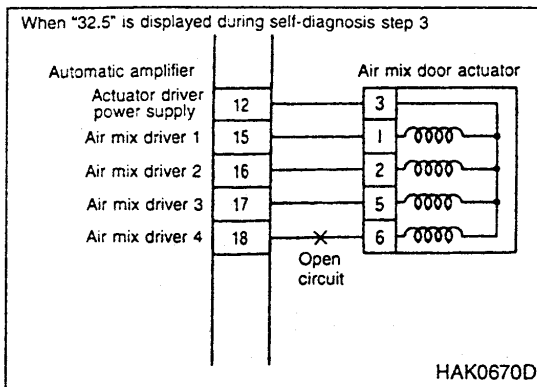

- When an open-circuit failure is displayed for all four terminals of each actuator, there is a possibility of a disconnected connector, or broken harness of the actuator driver power source.
- The self-diagnosis cannot detect short-circuit between actuator driver signals, but the actuators will vibrate when actuated.

### Step 4 — Each output device check

Display shows "41" in the step 4 mode. When the DEF switch is pushed it switches from 42→43→44→45→46→41. As indicated in the following table, the automatic amplifier forcefully outputs to each actuator, blower fan motor, and compressor in response to the display code. Confirm and check each output operation status by observing, listening to the operating sound, placing hand at the air outlet, or using other methods.

The operation status of each actuator, blower fan motor, and compressor cannot be confirmed on the display.

### Display code for output device and status

Output device	Display code	41	42	43	44	45	46
Mode door		VENT	B/L	B/L	FOOT	D/F	DEF
Intake door		Recirculation	Recirculation	20% ambient	Ambient	Ambient	Ambient
Air mix door		Full cold	Full cold	Open 50%	Open 50%	Full hot	Full hot
Blower fan motor		35%	75%	61%	61%	61%	100%
Compressor		ON	ON	ON	OFF	OFF	ON
Air purifier (only when connected)		ON	ON	ON	OFF	OFF	ON

The blower fan motor revolution is controlled by the duty ratio signal outputted from the automatic amplifier. (For duty ratio, refer to "Blower Fan Motor System Check" on page HA-15.)

### Step 5 — Detected temperature display for each sensor

Display shows "5" in the step 5 mode. Every time the DEF switch is pushed, the detected sensor temperature is displayed in 0.5°C increments.

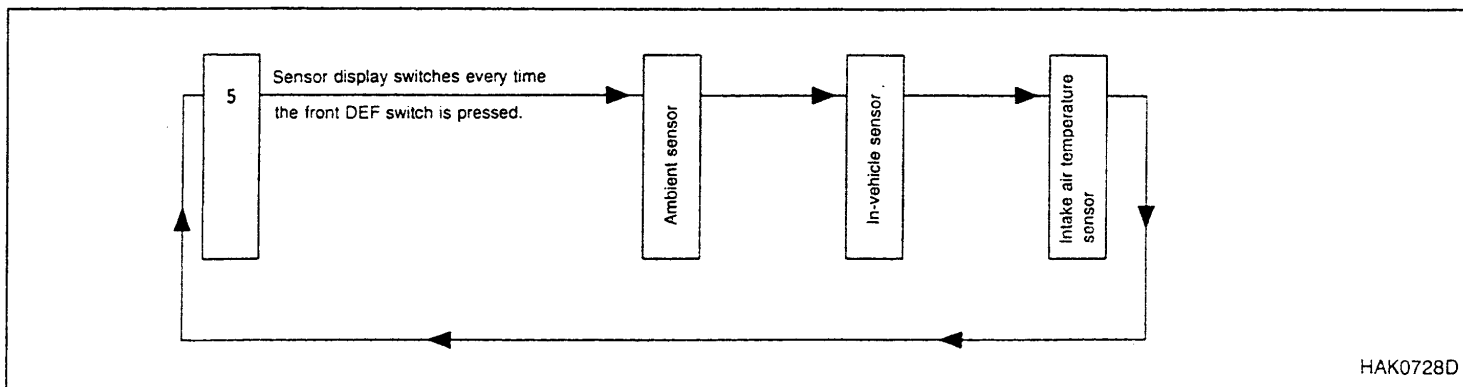



## Magnet Clutch System Check

### MAGNET CLUTCH

Disconnect the compressor connector. Apply approx. 12V to the compressor to check the magnet clutch operation.

### AIR CONDITIONER RELAY

- Remove the air conditioner relay. Apply approx. 12V between the air conditioner relay terminals No. 1 and 2. Check the relay operation sound.
- Check the continuity between terminals No. 3 and 5.

### REFRIGERANT CHARGE AMOUNT

- Connect the manifold gauge to the vehicle side service valve.
- Check that the lower pressure side (gauge pressure) is more than approx. 0.18 MPa (1.8 kg/cm<sup>2</sup>·G).

### ECM

Start the engine, and short-circuit the ECM terminal No. 14 to the ground. Check the magnet clutch operation.

### INTAKE AIR TEMPERATURE SENSOR

Start the engine, and short-circuit the intake air temperature sensor terminal No. 1 to the ground. Check the magnet clutch operation.

## Blower Fan Motor System Check

### BLOWER FAN MOTOR

- Disconnect the blower fan motor connector. Short-circuit the blower fan motor terminals No. 2 and 5 to the ground. Apply approx. 12V to the terminal No. 6, and check the motor operation.
- Connect the blower fan motor connector. Turn the ignition switch to the ON position, and change the fan switch from 1st to 4th. Check the blower fan motor terminal No. 5 with an oscilloscope. When the terminal No. 5 is normal according to the following table and the fan airflow does not change, this indicates a faulty blower fan motor.

When the terminal No. 5 results differ from the following table and the fan airflow does not change, this indicates either a faulty harness between the blower fan motor and automatic amplifier, or a faulty automatic amplifier.

GI

EC

AT

BR

ST

RS



HA

EL

SD

# FULLY AUTOMATIC AIR CONDITIONER

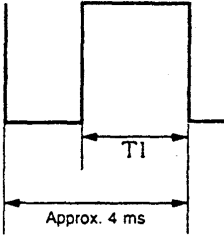
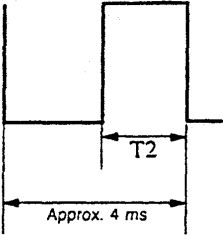
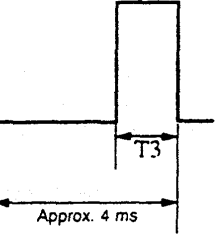
## Blower Fan Motor System Check (Cont'd)

	1st speed	2nd speed	3rd speed	4th speed
Terminal No. 5 (oscilloscope)	 <p>T1: Approx. 3.2 ms</p> <p>Duty ratio: Approx. 20%</p>	 <p>T2: Approx. 2.2 ms</p> <p>Duty ratio: Approx. 45%</p>	 <p>T3: Approx. 1.44 ms</p> <p>Duty ratio: Approx. 64%</p>	 <p>Duty ratio: Approx. 100%</p>
$\text{Duty ratio} = \frac{\text{Approx. } 4 \text{ ms} - T_x}{\text{Approx. } 4 \text{ ms}} \times 100\%$				

HAK0665D

### BLOWER FAN RELAY

- Remove the blower fan relay. Apply approx. 12V to the blower fan relay terminals No. 1 and 2. Check the relay operation sound.
- Check the continuity between terminals No. 3 and 5.

### Actuator System Check

#### DOOR ACTUATOR MOTOR

Disconnect every door actuator connector. Check the continuity between each door actuator terminals No. 3 and 1, 3 and 2, 3 and 5, and 3 and 6.

#### DOOR ACTUATOR HARNESS

- Check the continuity between the automatic amplifier and every actuator.
- Check that there is no short-circuit between actuator driver signals. (If there is a short-circuit, the actuators will vibrate during operation.)

# FULLY AUTOMATIC AIR CONDITIONER

## Trouble Diagnosis for Each Symptom

Symptom	Operation check	Malfunctioning unit	Probable cause
No airflow Airflow does not change.	Check blower fan motor operation. (Refer to "Blower Fan Motor System Check".)	Blower fan motor	Faulty blower fan motor
	The above is normal.	Automatic amplifier	Faulty automatic amplifier
Temperature control malfunction	Common item (Check and confirm this item along with the following three items.)	Check attachment status of the air mix door actuator.	Air mix door Faulty attachment of air mix door rod, or air mix door lever Faulty air mix door system (damage, lock, etc.)
		Abnormal display in self-diagnosis step 3	Air mix door actuator Faulty air mix door actuator system harness (Refer to "Actuator System Check".)
		Check that the air mix door operates when the temperature adjustment dial is set to 18°C or 32°C.	Air mix door actuator Refer to "Actuator System Check".
		Abnormal display in self-diagnosis step 2	Sensor Faulty sensor (Refer to "Component Parts Inspection".) Faulty sensor harness
	No cool airflow (Flow amount is normal.)	Magnet clutch does not operate with AUTO switch, or A/C switch.	Magnet clutch Refer to "Magnet Clutch System Check".
		Check refrigerant charge amount. Check the performance.	Cooler cycle Refer to "Performance Test".
		The above is normal.	Automatic amplifier Faulty automatic amplifier
	No warm airflow (Flow amount is normal.)	After warming up, the heater core inlet and outlet hoses are not warm.	Coolant Engine coolant failure Clogged heater hose or heater core
		The above is normal.	Automatic amplifier Faulty automatic amplifier
	Large in-vehicle temperature difference in relation to temperature setting	Blower fan motor speed does not change even when the fan switch is changed.	Blower fan motor Refer to "Blower Fan Motor System Check".
		When the fan switch is in 4th, smoke is not drawn in from the in-vehicle sensor inlet.	Aspirator Faulty aspirator Clogged or disconnected aspirator duct
		Check the setting difference between the set temperature and control temperature.	— Error in temperature difference setting
The above is normal.		Automatic amplifier Faulty automatic amplifier	
Air outlet does not switch.	Check mode door operation.	Mode door Faulty attachment of mode door lock, mode door link, or mode door lever Faulty mode door system (damage, lock, etc.)	
	Abnormal display in self-diagnosis step 3	Mode door actuator Faulty mode door actuator system harness (Refer to "Actuator System Check".)	
	Normal display in self-diagnosis step 3	Mode door actuator Refer to "DOOR ACTUATOR HARNESS", "Actuator System Check".	
	The above is normal.	Automatic amplifier Faulty automatic amplifier	
Air inlet does not switch.	Check intake door operation.	Intake door Faulty attachment of intake door lever Faulty intake door system (damage, lock, etc.)	
	Abnormal display in self-diagnosis step 3	Intake door actuator Faulty intake door actuator system harness (Refer to "Actuator System Check".)	
	Normal display in self-diagnosis step 3	Intake door actuator Refer to "DOOR ACTUATOR HARNESS", "Actuator System Check".	
	The above is normal.	Automatic amplifier Faulty automatic amplifier	

GI

EC

AT

BR

ST

RS

HA

EL

SD

# FULLY AUTOMATIC AIR CONDITIONER

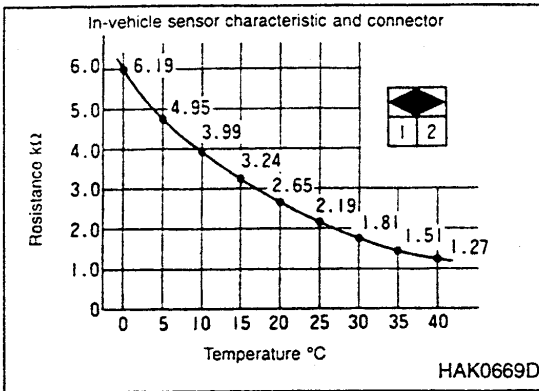

## Component Parts Inspection

### IN-VEHICLE SENSOR

Disconnect the in-vehicle sensor connector. Check the resistance between the sensor connector terminals No. 1 and 2.

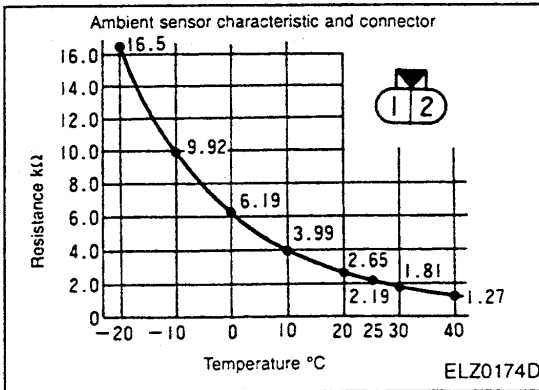

### AMBIENT SENSOR

Disconnect ambient sensor connector. Check the resistance between the sensor connector terminals No. 1 and 2.

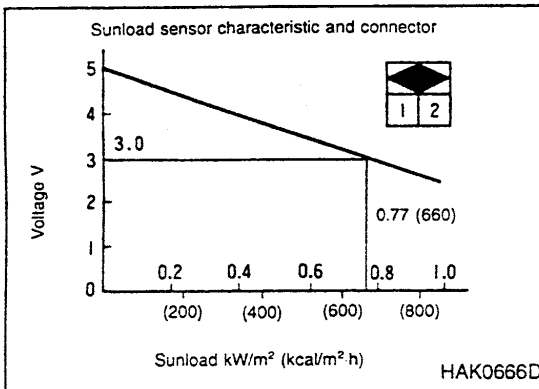

### SUNLOAD SENSOR

1. Disconnect the sunload sensor connector.
2. Turn the ignition switch ON.
3. Check that the voltage between the automatic amplifier connector (vehicle side) terminal No. 34 and body ground, is approx. 4.6V.
4. When normal, proceed to step 5.
  - When abnormal, the automatic amplifier is faulty. Or, the harness between the automatic amplifier and sunload sensor is faulty.
5. Turn the ignition switch OFF.
6. Connect the sunload sensor connector.
7. Turn the ignition switch ON.
8. Check the voltage between the automatic amplifier connector (vehicle side) terminal No. 34 and body ground.
  - When indoors, check the voltage by applying a light of approx. 60W. (Check the voltage with the light placed close to and away from the sensor.)
  - The sunload during a sunny day is equivalent to approx. 767 W/m<sup>2</sup> (660 kcal/m<sup>2</sup>·h).

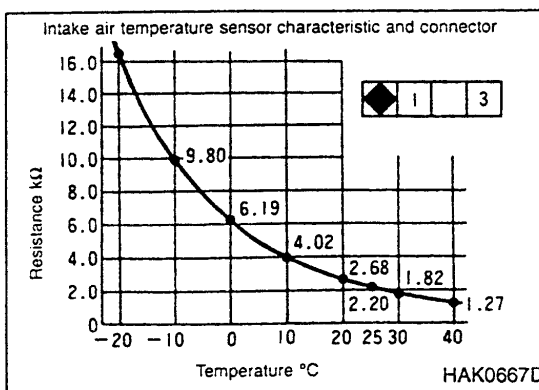

### INTAKE AIR TEMPERATURE SENSOR

Disconnect the intake air temperature sensor connector. Check the resistance between the sensor connector terminals No. 1 and 2.

### THERMAL TRANSMITTER

Refer to EL section ("Component Parts Inspection", "COMBINATION METER").

# ELECTRICAL SYSTEM

## SECTION **EL**

### CONTENTS

<b>CENTRAL DOOR LOCK SYSTEM</b> .....	2	<b>XENON HEADLAMP SYSTEM</b> .....	15
Component Parts Location.....	2	Trouble Diagnoses.....	15
Circuit Diagram.....	2	<b>IGNITION KEY-OPERATED ILLUMINATION</b>	
Combination Meter (meter control unit) Input/		<b>SYSTEM</b> .....	17
Output Signal Specifications.....	2	Component Parts Location.....	17
Inspection before Trouble Diagnoses.....	3	Circuit Diagram.....	17
Trouble Diagnoses.....	3	Meter Control Unit Input/Output Signal	
<b>REMOTE CONTROL ENTRY SYSTEM</b> .....	4	Specifications.....	17
Component Parts Location.....	4	<b>METER</b> .....	18
Circuit Diagram.....	4	Combination Meter.....	18
Remote Control Entry Control Unit Input/Output		Triple Meter.....	20
Signal Specifications.....	5	<b>COMBINATION METER</b> .....	21
System Check.....	5	System Description.....	21
Inspection before Trouble Diagnoses.....	6	Component Parts Location.....	21
Trouble Diagnoses.....	6	Diagnosis Function.....	21
Component Parts Inspection.....	6	Meter-related Circuit Diagram.....	22
ID Code Entry Procedure.....	7	Trouble Diagnoses.....	23
<b>POWER WINDOW SYSTEM</b> .....	8	Combination Meter Input/Output Signal	
System Description.....	8	Specifications.....	25
Precautions.....	8	Component Parts Inspection.....	26
Component Parts Location.....	8	<b>TRIPLE METER</b> .....	29
Circuit Diagram.....	9	Special Service Tool.....	29
Power Window Main Switch Input/Output Signal		Component Parts Location.....	29
Specifications.....	9	Circuit Diagram.....	29
Inspection before Trouble Diagnoses.....	11	Triple Meter Input/Output Signal Specifications.....	30
Trouble Diagnoses.....	11	Component Parts Inspection.....	30
<b>SUNROOF SYSTEM</b> .....	12	<b>IGNITION KEY WARNING BUZZER AND LIGHT</b>	
Component Parts Location.....	12	<b>WARNING BUZZER</b> .....	31
Circuit Diagram.....	12	Component Parts Location.....	31
Sunroof Switch and Sunroof Motor Assembly		Circuit Diagram.....	31
Input/Output Signal Specifications.....	12	Meter Control Unit Input/Output Signal	
<b>AUTO LIGHT SYSTEM</b> .....	13	Specifications.....	31
Component Parts Location.....	13	<b>FRONT WIPER</b> .....	32
Auto Light Control Unit Input/Output Signal		Component Parts Location.....	32
Specifications.....	13	Circuit Diagram.....	32
Circuit Diagram.....	14	Front Wiper Input/Output Signal Specifications.....	32
Trouble Diagnoses.....	14		

# CONTENTS (Cont'd)

<b>REAR WIPER</b> .....	33
Component Parts Location .....	33
Circuit Diagram .....	33
Rear Wiper Amplifier Input/Output Signal Specifications .....	33
<b>REAR DEFOGGER AND HEATER MIRROR</b> .....	34
Component Parts Location .....	34
Circuit Diagram .....	34

Meter Control Unit Input/Output Signal Specifications .....	34
<b>WIPER DEICER</b> .....	35
Component Parts Location .....	35
Circuit Diagram .....	35
Wiper Deicer Switch Input/Output Signal Specifications .....	35

GI

EC

AT

BR

ST

RS

HA

**EL**

SD

# CENTRAL DOOR LOCK SYSTEM

## Component Parts Location

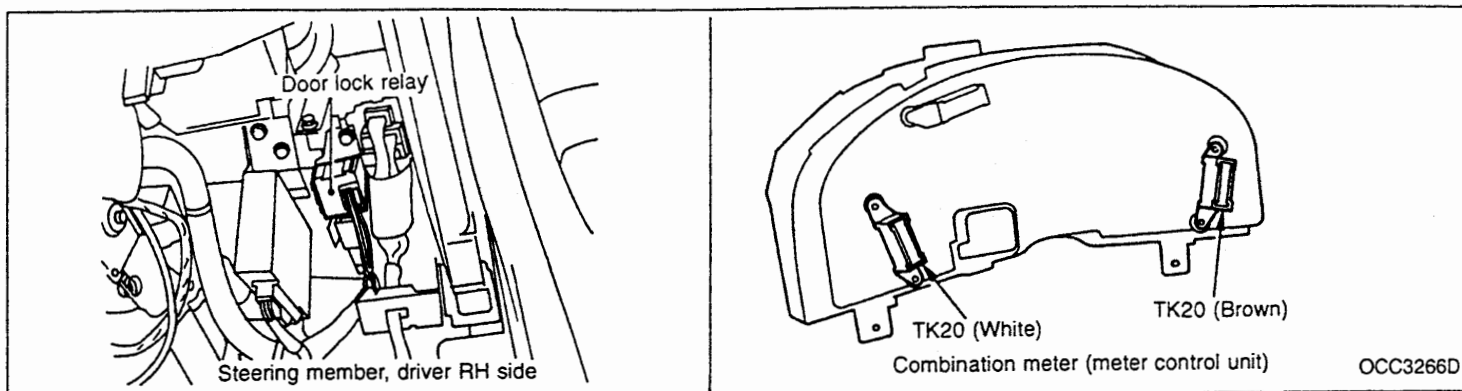

## Circuit Diagram

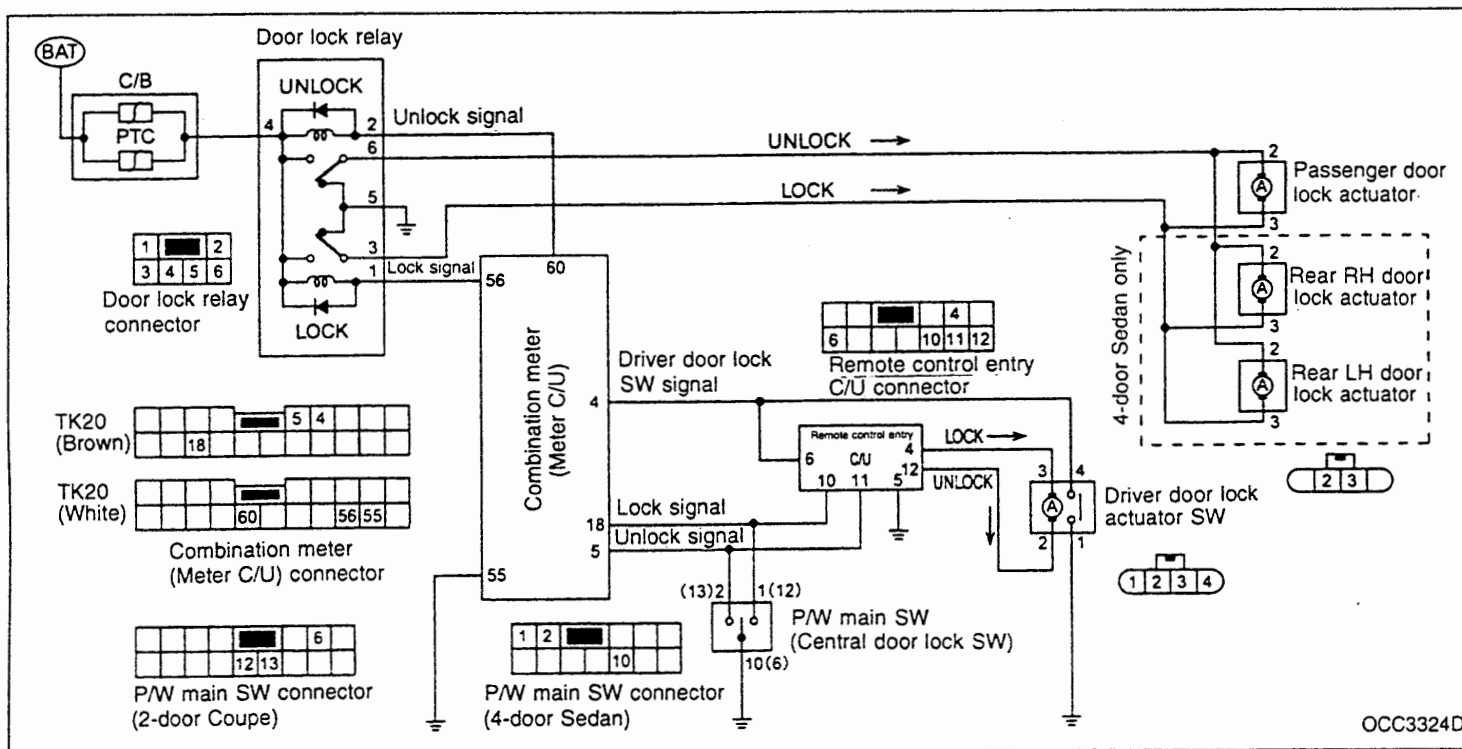

## Combination Meter (meter control unit) Input/Output Signal Specifications

Terminal No.	Signal name	Operation or condition	Specification
4	Driver door lock switch signal	Unlocked (ON)	Approx. 0V
		Locked (OFF)	Approx. 5V
5	Central door lock switch unlock signal	Unlocked (ON)	Approx. 0V
		Operation other than above (OFF)	Approx. 5V
18	Central door lock switch lock signal	Locked (ON)	Approx. 0V
		Operation other than above (OFF)	Approx. 5V
55	Ground	—	Approx. 0V
56	Passenger and rear RH & LH door lock actuator lock signal	Central door lock switch is locked.	Changes from approx. 12 to 0V and back to approx. 12V.
60	Passenger and rear RH & LH door lock actuator unlock signal	Central door lock switch is unlocked.	Changes from approx. 12 to 0V and back to approx. 12V.

# CENTRAL DOOR LOCK SYSTEM

## Inspection before Trouble Diagnoses

Check that components connectors are properly connected.

## Trouble Diagnoses

### SYMPTOM CHART

Symptom	Malfunctioning item	Possible cause
Passenger door lock and rear RH & LH door locks do not lock or unlock with the central door lock switch.	Power window main switch circuit	<ul style="list-style-type: none"> <li>● Faulty power window main switch (central door lock switch)</li> <li>● Faulty power window main switch (central door lock switch) to combination meter (meter control unit) harness</li> <li>● Faulty power window main switch (central door lock switch) ground circuit</li> </ul>
	Door lock relay circuit	<ul style="list-style-type: none"> <li>● Faulty door lock relay</li> <li>● Faulty door lock relay to combination meter (meter control unit) harness</li> <li>● Faulty door lock relay to door lock actuator harness</li> </ul>
	Combination meter (meter control unit)	<ul style="list-style-type: none"> <li>● Faulty combination meter (meter control unit)</li> </ul>
Passenger door lock, rear RH door lock, or rear LH door lock do not lock or unlock with the central door lock switch.	Door lock actuator circuit	<ul style="list-style-type: none"> <li>● Faulty door lock actuator</li> <li>● Faulty door lock actuator to door lock relay harness</li> </ul>
Passenger door lock and rear RH & LH door locks do not lock or unlock with the driver door lock knob. (They operate properly with the central door lock switch.)	Driver door lock switch circuit	<ul style="list-style-type: none"> <li>● Faulty driver door lock switch</li> <li>● Faulty driver door lock switch to combination meter (meter control unit) harness</li> <li>● Faulty driver door lock switch ground circuit</li> </ul>
	Combination meter (meter control unit)	<ul style="list-style-type: none"> <li>● Faulty combination meter (meter control unit)</li> </ul>

GI

EC

AT

BR

ST

RS

HA

EL

SD



# REMOTE CONTROL ENTRY SYSTEM

## Component Parts Location

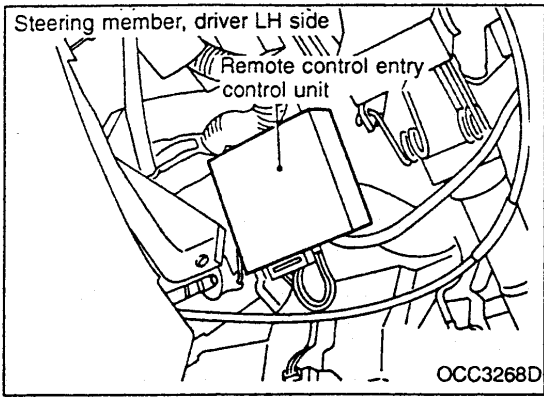

## Circuit Diagram

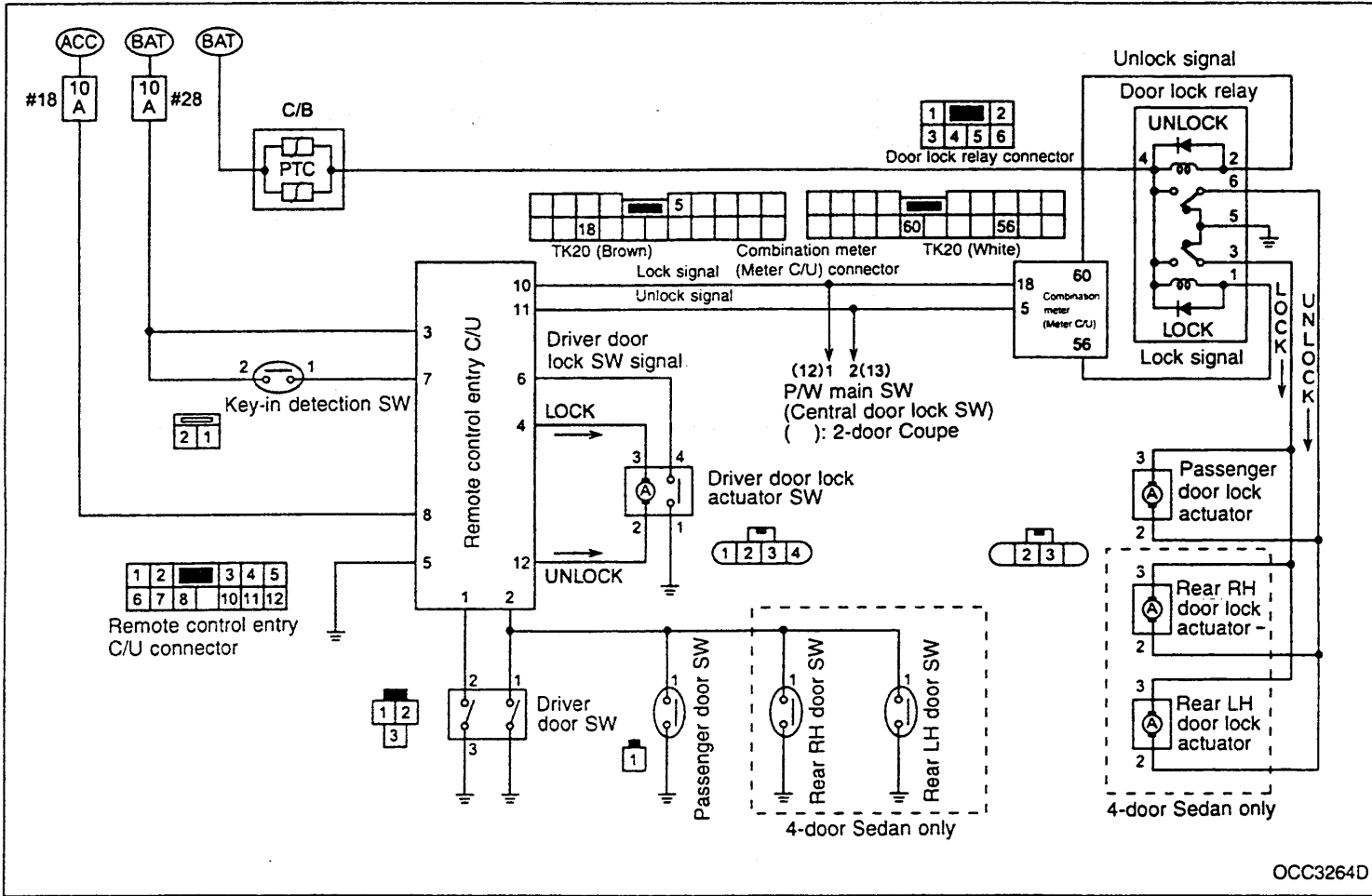

# REMOTE CONTROL ENTRY SYSTEM

## Remote Control Entry Control Unit Input/Output Signal Specifications

Terminal No.	Signal name	Operation or condition	Specification
1	Driver door switch input signal	Close the driver door. (OFF)	Approx. 12V
		Open the driver door. (ON)	Approx. 0V
2	All door switch input signal	Close all the doors. (OFF)	Approx. 12V
		Open one of the doors. (ON)	Approx. 0V
3	Battery	—	Approx. 12V
4	Driver door lock actuator lock output signal	Lock with the remote control.	Changes from approx. 0 to 12V and back to approx. 0V.
5	Ground	—	Approx. 0V
6	Driver door lock switch signal	Locked (OFF)	Approx. 5V
		Unlocked (ON)	Approx. 0V
7	Key-in detection switch input signal	Ignition key Insert (ON)	Approx. 12V
		Remove (OFF)	Approx. 0V
8	ACC power supply	Ignition switch to ACC	Approx. 12V
10	Passenger door and rear RH & LH door lock output signal	Press the lock switch on the remote control.	Changes from approx. 5 to 0V and back to approx. 5V.
11	Passenger door and rear RH & LH door unlock output signal	Press the unlock switch on the remote control.	Changes from approx. 5 to 0V and back to approx. 5V.
12	Driver door lock actuator unlock output signal	Unlock with the remote control.	Changes from approx. 0 to 12V and back to approx. 0V.

### System Check

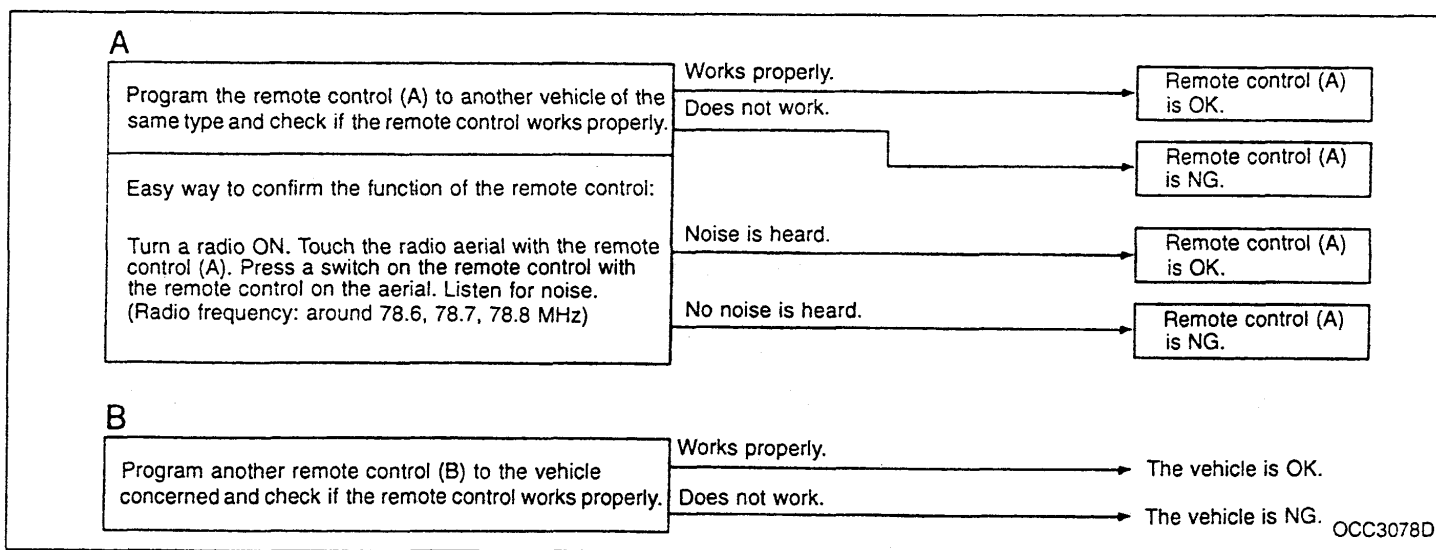

Operation check		Check item
System check A	System check B	
Remote control (A) is OK.	The vehicle is OK.	Program the remote control (A) to the vehicle concerned again and check for proper operation.
Remote control (A) is OK.	The vehicle is NG.	Perform trouble diagnosis to determine what causes the problem.
Remote control (A) is NG.	The vehicle is OK.	Check the remote control (A) battery voltage.
Remote control (A) is NG.	The vehicle is NG.	Check the remote control (A) battery voltage and then perform trouble diagnosis to determine what causes the problem.

# REMOTE CONTROL ENTRY SYSTEM

## Inspection before Trouble Diagnoses

- Check system.
- Check that other systems that use the following signals work properly.
- Check that component connectors are connected properly.

## Trouble Diagnoses

### SYMPTOM CHART

Symptom	Malfunctioning item	Possible cause
None of the doors lock with the remote control switch.	Door switch circuit	● Faulty door switch to remote control entry control unit harness
	Key-in detection switch circuit	● Faulty key-in detection switch to remote control entry control unit harness
	Remote control entry control unit	● Faulty remote control entry control unit
None of the doors unlock with the remote control switch.	Key-in detection switch circuit	● Faulty key-in detection switch to remote control entry control unit harness
	Remote control entry control unit	● Faulty remote control entry control unit
Door locks other than the driver door do not operate with the remote control switches.	Central door lock system circuit	● Refer to "CENTRAL DOOR LOCK SYSTEM", EL-2. ● Faulty combination meter (meter control unit) to remote control entry control unit harness
	Remote control entry control unit	● Faulty remote control entry control unit
Only the driver door lock does not operate with the remote control switch.	Driver door lock actuator circuit	● Faulty driver door lock actuator ● Faulty driver door lock actuator to remote control entry control unit harness
	Remote control entry control unit	● Faulty remote control entry control unit

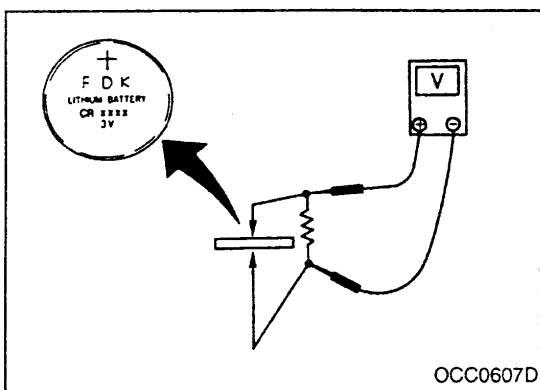

## Component Parts Inspection

### BATTERY CHECK

Specification: Approx. 2.5 - 3.0V

#### CAUTION:

Connect resistance (300Ω) so that the current is approx. 10 mA before checking the battery.

Use lithium photo battery (CR1620 or equivalent) for replacement.

# REMOTE CONTROL ENTRY SYSTEM

## ID Code Entry Procedure

Enter the identity (ID) code manually when:

- remote controller or control unit is replaced.
- an additional remote controller is activated.

To enter the ID code, follow the procedures below.

### PROCEDURE

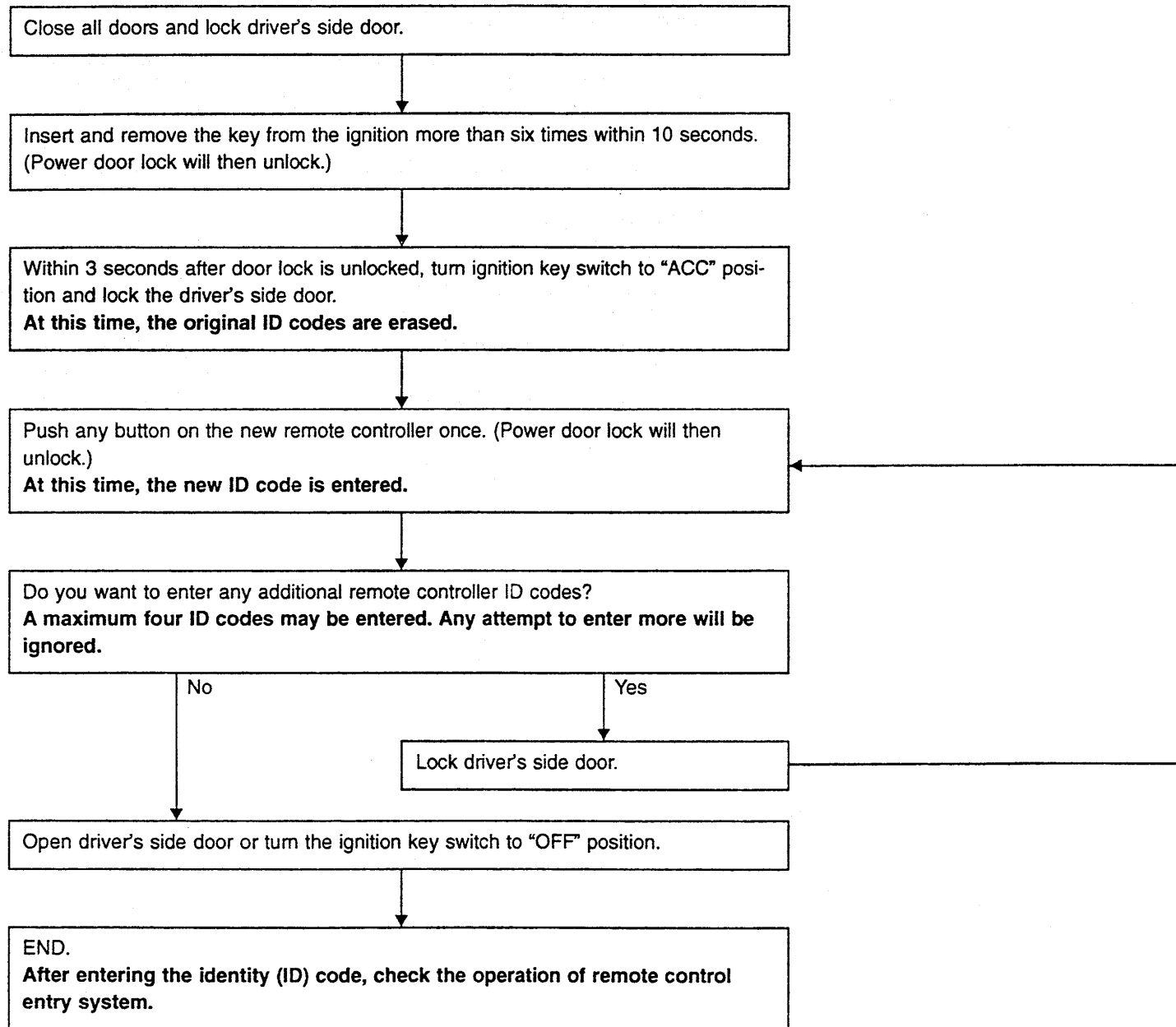

### NOTE

- If you need to activate more than two additional new remote controllers, repeat the procedure "Additional ID code entry" for each new remote controller.
- If the same ID code that exists in the memory is input, the entry will be ignored.
- Entry of maximum four ID codes is allowed and any attempt to enter more will be ignored.

GI

EC

AT

BR

ST

RS

HA

EL

SD

# POWER WINDOW SYSTEM

## System Description

- When the ignition switch is turned OFF, timer function allows the driver door power window to operate for up to approximately 15 minutes. Opening (door switch ON) and closing (door switch OFF) the driver door or entering the ignition switch OFF to ON signal will reset the timer.
- If the driver door window is obstructed when it is going up, the window moves down approximately 150 mm.

## OPERATING CONDITIONS

- The driver door window is between fully-open position and almost fully-closed position (with the limit switch ON).
- Automatic operation when the ignition switch is turned ON
- Automatic or manual operation when the ignition switch is turned to any position other than ON (with the timer active)

## Precautions

- When the driver door window is between fully-open position and almost fully-closed position with the limit switch ON, removing or installing the battery or the power window main switch will deactivate the auto UP mode and the timer function.
- If the step above has been taken, operate the power window switch to close the driver door glass fully. This activates the auto UP mode and the timer function.

## Component Parts Location

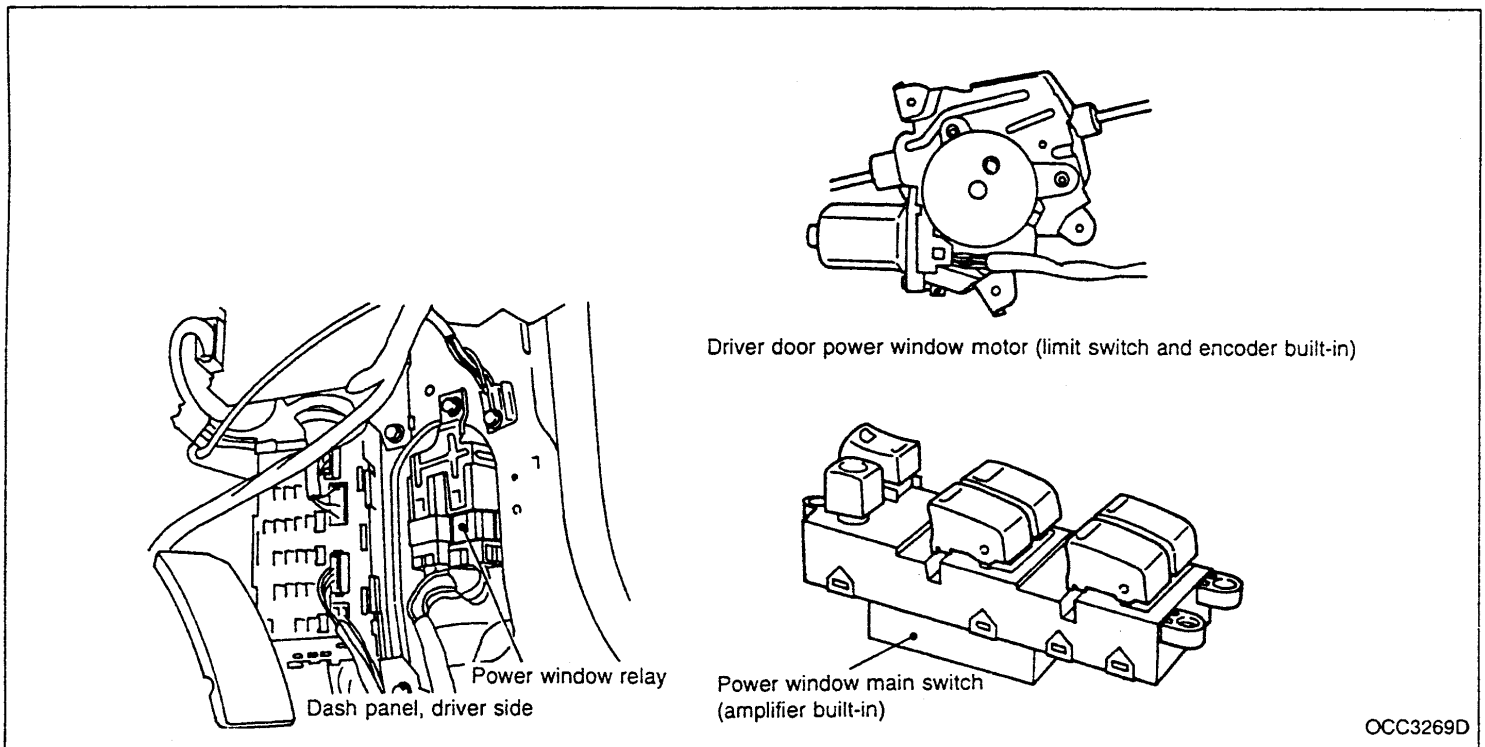

# POWER WINDOW SYSTEM

## Circuit Diagram

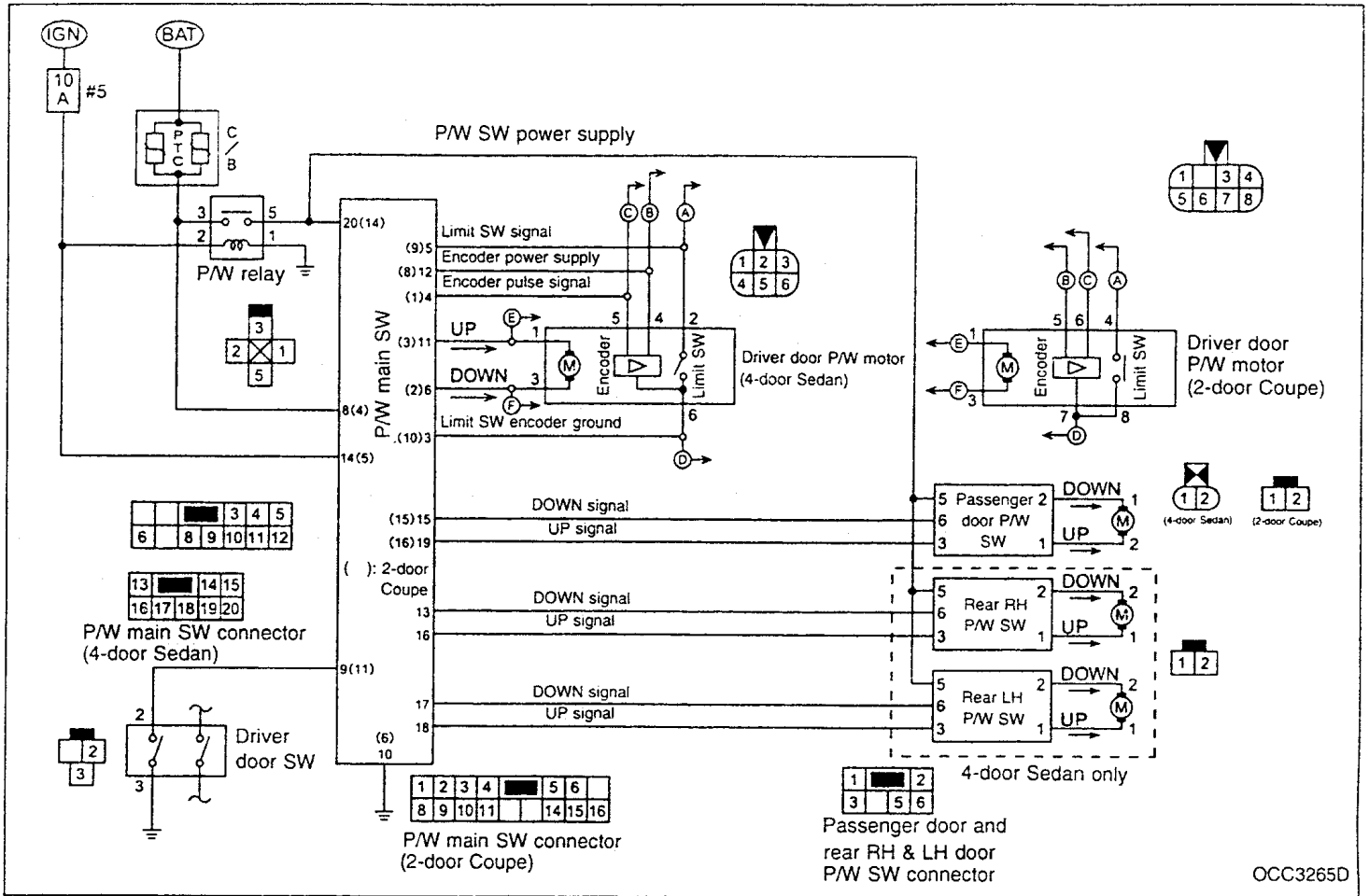

## Power Window Main Switch Input/Output Signal Specifications

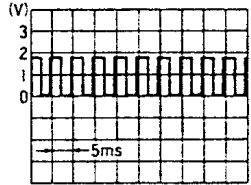
Terminal No.	Signal name	Measuring condition		Specification
		Ignition switch	Operation or condition	
3 (10)	Limit switch and encoder ground	ON or another position (Timer is in operation.)	—	Approx. 0V
4 (1)	Encoder pulse signal	ON or another position (Timer is in operation.)	Power window motor is in operation.	Approx. 2V  OCC3270D
5 (9)	Limit switch signal	ON or another position (Timer is in operation.)	Driver door window is between fully-open position and almost fully-closed position. (ON)	Approx. 0V
			Driver door window is between almost fully-closed position and fully-closed position. (OFF)	Approx. 5V
6 (2)	Driver door power window motor DOWN signal	ON or another position (Timer is in operation.)	DOWN operation	Approx. 12V
			Other than DOWN operation	Approx. 0V
8 (4)	Battery	—	—	Approx. 12V

( ) : 2-door Coupe

# POWER WINDOW SYSTEM

## Power Window Main Switch Input/Output Signal Specifications (Cont'd)

Terminal No.	Signal name	Measuring condition		Specification
		Ignition switch	Operation or condition	
9 (11)	Driver door switch signal	—	Driver door is opened. (ON)	Approx. 0V
			Driver door is closed. (OFF)	Approx. 12V
10 (6)	Ground			Approx. 0V
11 (3)	Driver door power window motor UP signal	ON or another position (Timer is in operation.)	UP operation	Approx. 12V
			Other than UP operation	Approx. 0V
12 (8)	Encoder power supply	ON or another position (Timer is in operation.)	—	Approx. 5V
13	Rear RH door power window DOWN signal	ON	The rear RH window DOWN switch in the main switch is operated.	Approx. 12V
			Operation other than above	Approx. 0V
14 (5)	Ignition power supply	ON	—	Approx. 12V
15 (15)	Passenger door power window DOWN signal	ON	The passenger door DOWN switch in the main switch is operated.	Approx. 12V
			Operation other than above	Approx. 0V
16	Rear RH door power window UP signal	ON	The rear RH window UP switch in the main switch is operated.	Approx. 12V
			Operation other than above	Approx. 0V
17	Rear LH door power window DOWN signal	ON	The rear LH window DOWN switch in the main switch is operated.	Approx. 12V
			Operation other than above	Approx. 0V
18	Rear LH door power window UP signal	ON	The rear LH window UP switch in the main switch is operated.	Approx. 12V
			Operation other than above	Approx. 0V
19 (16)	Passenger door power window UP signal	ON	The passenger door UP switch in the main switch is operated.	Approx. 12V
			Operation other than above	Approx. 0V
20 (14)	Power supply to the passenger door and rear RH & LH door power window switch	ON	—	Approx. 12V

( ): 2-door Coupe

# POWER WINDOW SYSTEM

## Inspection before Trouble Diagnoses

- Check that other systems that use the following signals work properly.
- Check that component connectors are connected properly.

## Trouble Diagnoses

### SYMPTOM CHART

Symptom	Malfunctioning item	Possible cause
Timer function is not deactivated, with the operation conditions met, when the driver door switch is turned ON and OFF.	Driver door switch circuit	● Faulty driver door switch to power window main switch harness
	Power window main switch	● Faulty power window main switch
The driver door glass is not reversed when it was obstructed.	Limit switch circuit	<ul style="list-style-type: none"> <li>● Faulty driver door power window motor (Limit switch is poorly adjusted.)</li> <li>● Faulty driver door power window motor (limit switch)</li> <li>● Faulty driver door power window motor (limit switch) to power window main switch harness</li> </ul>
	Power window main switch	● Faulty power window main switch
The driver door glass is reversed when it goes up and comes near the fully-closed position in the auto UP mode.	Limit switch circuit	<ul style="list-style-type: none"> <li>● Faulty driver door power window motor (Limit switch is poorly adjusted.)</li> <li>● Faulty driver door power window motor (limit switch)</li> <li>● Faulty driver door power window motor (limit switch) to power window main switch harness</li> </ul>
	Power window main switch	● Faulty power window main switch
The driver door glass is reversed as soon as it starts to go up in the auto UP mode.	Encoder circuit	<ul style="list-style-type: none"> <li>● Faulty driver door power window motor (encoder)</li> <li>● Faulty driver door power window motor (encoder) to power window main switch harness</li> </ul>
	Power window main switch	● Faulty power window main switch
	Door glass slide condition	<ul style="list-style-type: none"> <li>● Foreign objects on the glass, glass run channel rubber (4-door Sedan) or weatherstrip (2-door Coupe)</li> <li>● Abrasion or deformation of glass run channel rubber (4-door Sedan) or weatherstrip (2-door Coupe)</li> <li>● Sash is not angled inboard or outboard properly (4-door Sedan) or glass is not angled inboard or outboard properly (2-door Coupe)</li> </ul>
The driver door glass is reversed at the position other than above when it is going up in the auto UP mode.	Power window main switch	● Faulty power window main switch
	Door glass slide condition	<ul style="list-style-type: none"> <li>● Foreign objects on the glass, glass run channel rubber (4-door Sedan), or weatherstrip (2-door Coupe)</li> <li>● Abrasion or deformation of glass run channel rubber (4-door Sedan) or weatherstrip (2-door Coupe)</li> <li>● Sash is not angled inboard or outboard properly (4-door Sedan) or glass is not angled inboard or outboard properly (2-door Coupe)</li> </ul>

GI

EC

AT

BR

ST

RS

HA

EL

SD



# SUNROOF SYSTEM

## Component Parts Location

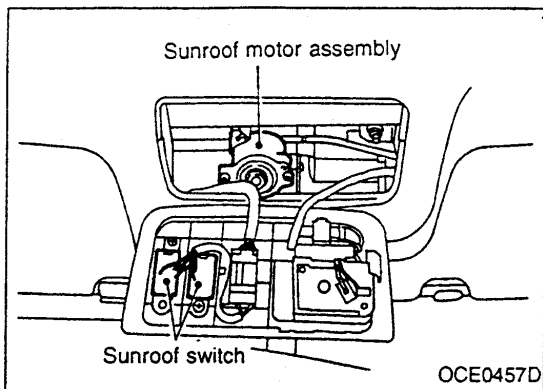

## Circuit Diagram

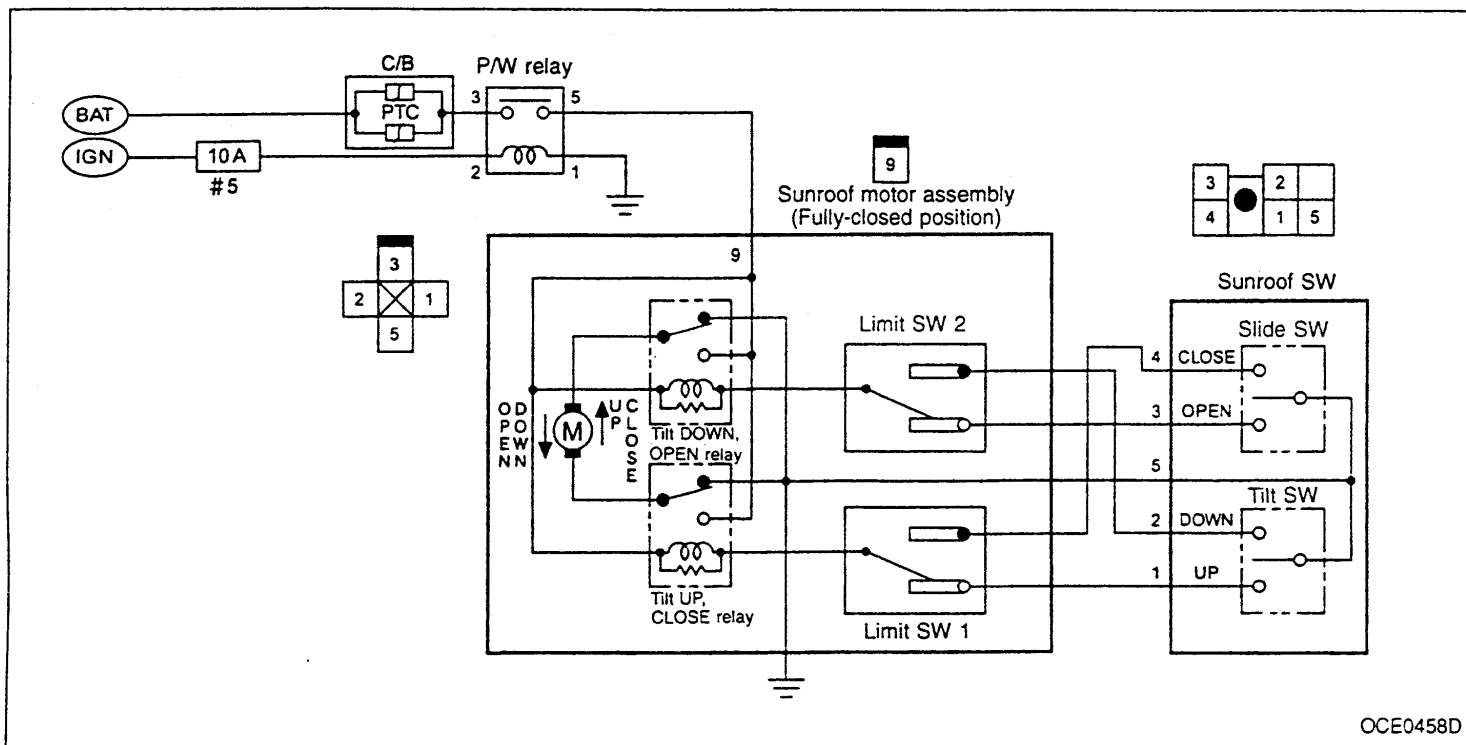

## Sunroof Switch and Sunroof Motor Assembly Input/Output Signal Specifications

Terminal No.	Measuring condition					
	Ignition switch	Operation				
		Fully closed	Fully closed position to fully open position	Fully open position to fully closed position	Fully closed position to tilt UP position	Tilt UP position to fully closed position
1	ON	Approx. 12V	0V	0V	Approx. 0V (Motor is running.)	Approx. 12V
2	ON	0V	0V	0V	Approx. 12V	Approx. 0V (Motor is running.)
3	ON	Approx. 12V	Approx. 0V (Motor is running.)	Approx. 12V	0V	0V
4	ON	0V	Approx. 12V	Approx. 0V (Motor is running.)	0V	0V
5	ON	Approx. 0V	Approx. 0V	Approx. 0V	Approx. 0V	Approx. 0V
9	ON	Approx. 12V	Approx. 12V	Approx. 12V	Approx. 12V	Approx. 12V

# AUTO LIGHT SYSTEM

## Component Parts Location

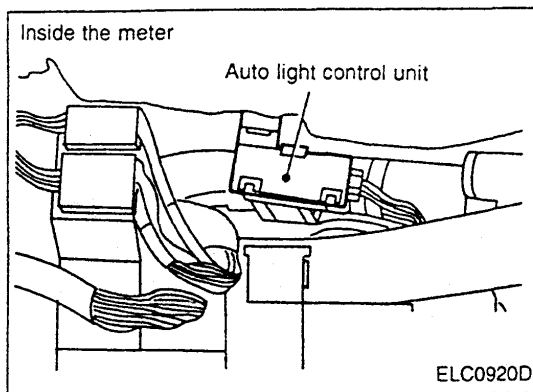

## Auto Light Control Unit Input/Output Signal Specifications

Terminal No.	Signal name	Measuring condition		Specification	
		Ignition switch	Operation or condition		
2	Tail lamp relay control signal	ON	Lighting switch: AUTO	Light is applied to the light sensor.	Approx. 12V
				Light is not applied to the light sensor.	Approx. 0V
3	Vehicle speed signal (2 pulses)	ON	Speedometer is in operation. (Vehicle speed is approximately 40 km/h.)		
4	Navigation screen dimming signal	ON	Lighting switch: 1ST	Light is applied to the light sensor.	Approx. 0V
				Light is not applied to the light sensor.	Approx. 12V
5	Ignition power supply	ON	—	Approx. 12V	
6	Headlamp relay control signal	ON	Lighting switch: AUTO	Light is applied to the light sensor.	Approx. 12V
				Light is not applied to the light sensor.	Approx. 0V
7	Lighting switch AUTO signal	ACC	Lighting switch	OFF	Approx. 12V
				AUTO	Approx. 0V
8	Ground	ON	—	Approx. 0V	
9	Driver door switch signal	ACC	Driver door switch	ON (Open)	Approx. 0V
				OFF (Closed)	Approx. 12V
10	ACC power supply	ACC	—	Approx. 12V	

GI

EC

AT

BR

ST

RS

HA

EL

SD



# XENON HEADLAMP SYSTEM

## Trouble Diagnoses

### DESCRIPTION

- Problems with xenon headlamps are as follows:  
They do not light up.  
They blink.  
They are not bright enough.
- In most cases the problems above are caused by faulty xenon bulbs.
- There might be the possibility that the problems are caused by faulty HID control unit or lamp sockets. Follow the diagnostic procedure to determine what causes the problem.

### PRECAUTIONS

- Connect or disconnect connectors with the lighting switch OFF.
- Do not touch harnesses, HID control unit, internal lamp, or metal part of the lamp while the lamps are ON (Lighting switch is ON).
- Before verifying that the lamps are ON, install the parts to the vehicle temporarily and connect the battery cable with the connector on the vehicle.
- If the electrical system is suspected to be the cause of the symptom, check for blown fuse or fusible link, broken connectors, disconnected terminals, or faulty engagement.
- Do not use wet hands when performing the trouble diagnoses.

### CIRCUIT DIAGRAM

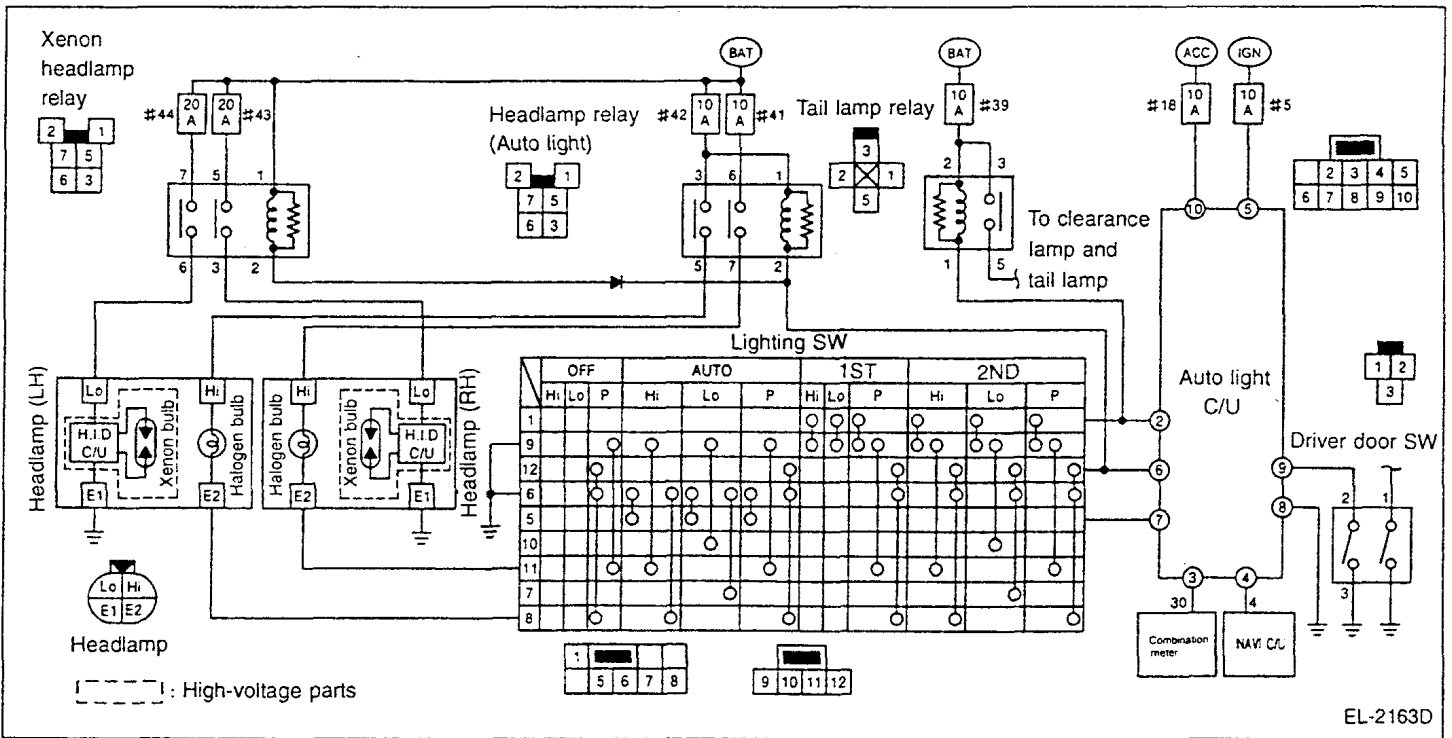

### CAUTION:

- Do not use a tester to diagnose the HID control unit circuit.
- Do not disassemble the HID control unit and harnesses (bulb socket harness and control unit harness).
- Immediately after the headlamps turn ON, brightness and emission color vary. This is a normal condition.
- When a bulb has reached the end of its life, the brightness becomes extremely low, the bulb continues to blink, or the light looks reddish.

# XENON HEADLAMP SYSTEM

## Trouble Diagnoses (Cont'd)

### DIAGNOSTIC PROCEDURE

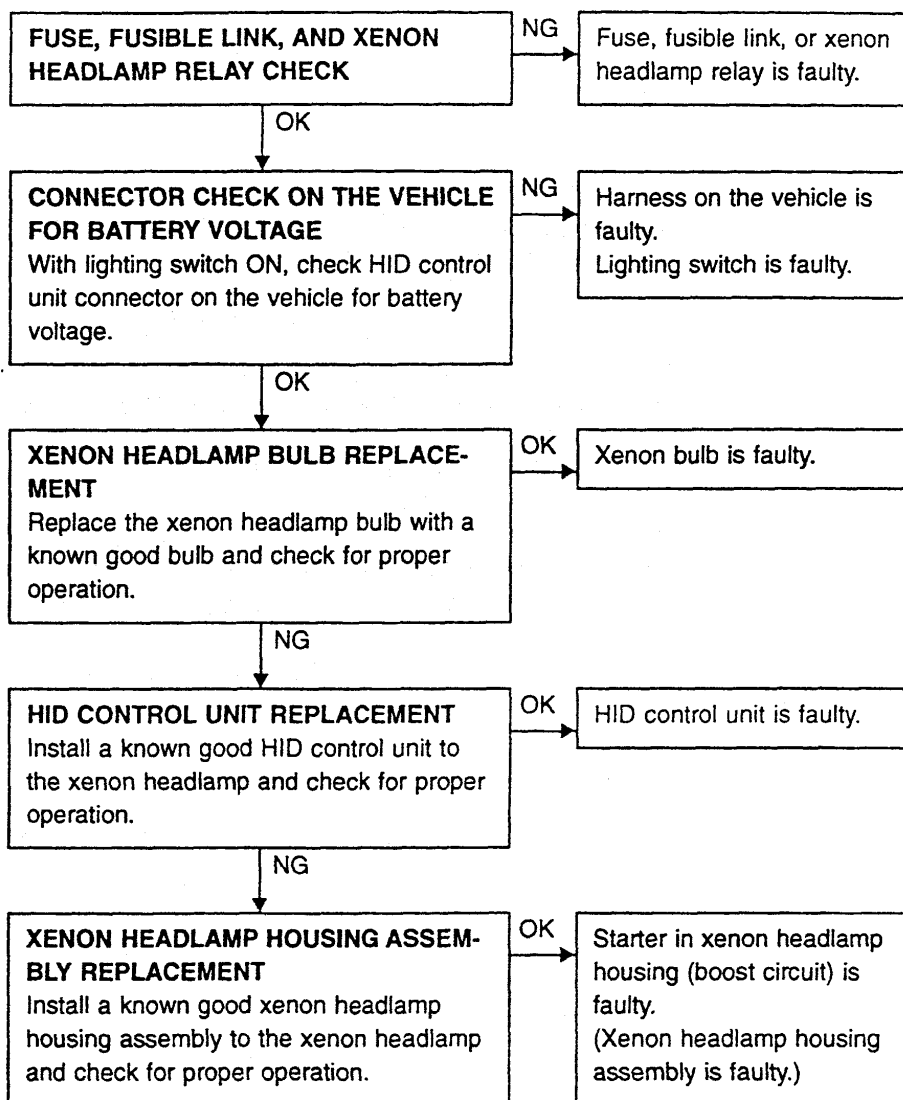

# IGNITION KEY-OPERATED ILLUMINATION SYSTEM

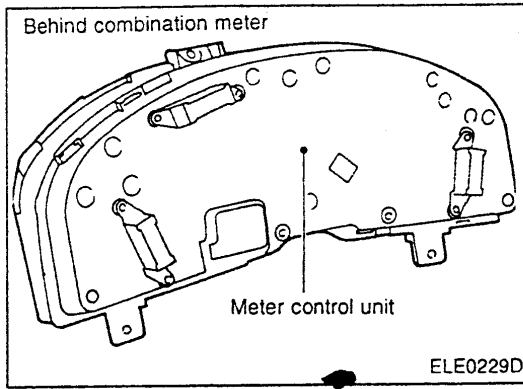

## Component Parts Location

## Circuit Diagram

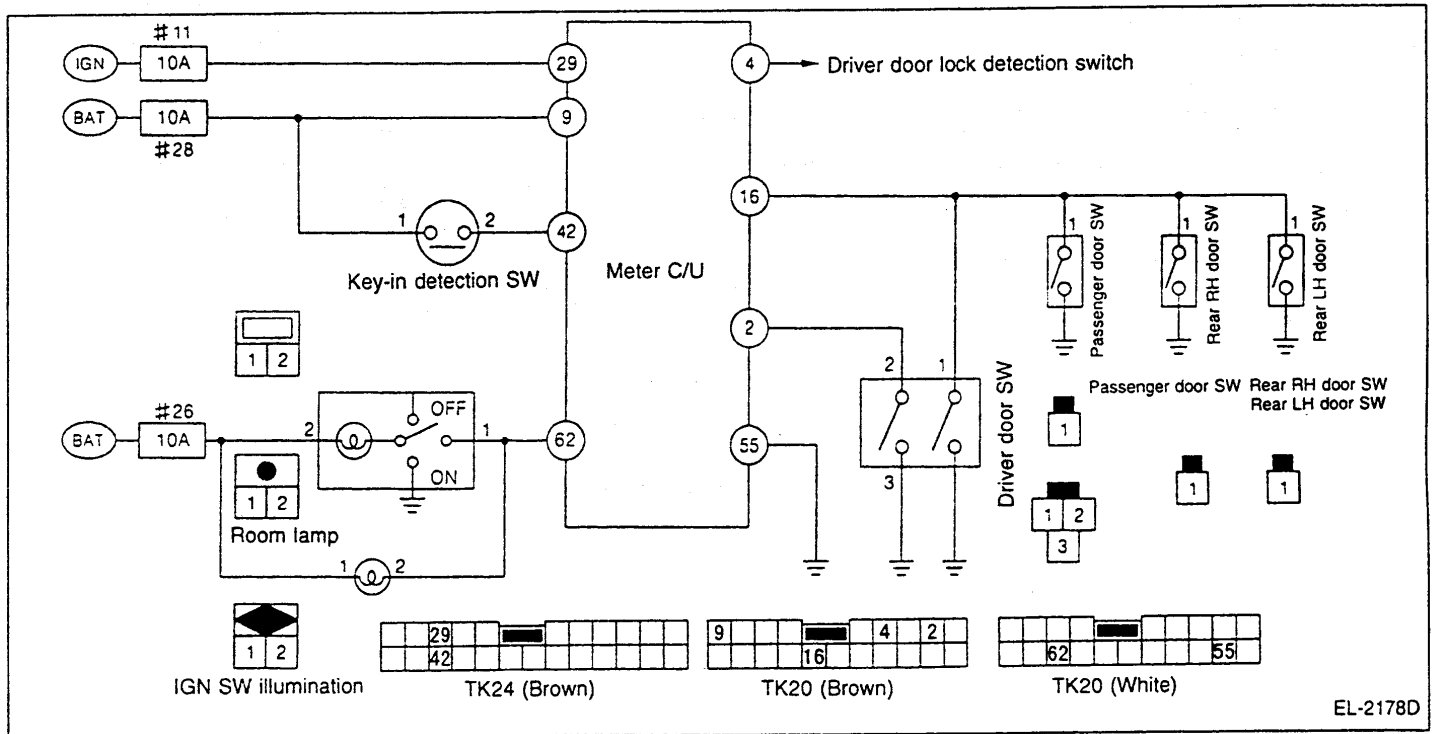

## Meter Control Unit Input/Output Signal Specifications

Terminal No.	Signal name	Measuring condition			Specification		
		Ignition switch	Operation or condition				
2	Driver door switch signal	OFF	Driver door switch	ON (Open)	Approx. 0V		
				OFF (Closed)	Approx. 12V		
4	Driver door lock signal	OFF	Door is unlocked. (Switch ON)		Approx. 0V		
			Door is locked. (Switch OFF)		Approx. 5V		
9	Battery	OFF	—		Approx. 12V		
16	Door switch signal	OFF	Open a door. (ON)		Approx. 0V		
			Close all the doors. (OFF)		Approx. 12V		
29	Ignition power supply	ON	—		Approx. 12V		
42	Key-in detection switch signal	OFF	Remove the ignition key.		Approx. 0V		
			Insert the ignition key.		Approx. 12V		
55	Ground	ON	—		Approx. 0V		
62	Room lamp, ignition switch illumination signal	OFF	Room lamp switch: Neutral position	Insert the ignition key.	Each door switch	ON (Open)	Approx. 0V
				Remove the ignition key from the key cylinder.	OFF (Closed)	Approx. 12V	
		—	Room lamp switch: Neutral position	Close all the doors.		Remove the ignition key from the key cylinder.	Approx. 0V*
						Turn the ignition switch ON.	Approx. 12V

\*: The voltage becomes approx. 12V approx. 20 seconds after the ignition key is removed.

# METER

## Combination Meter

### REMOVAL AND INSTALLATION

Parts included in this procedure:

- Column cover
- Cluster lid A
- Combination switch

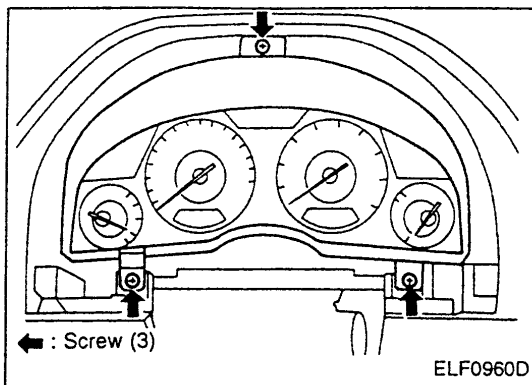

### DISASSEMBLY AND ASSEMBLY

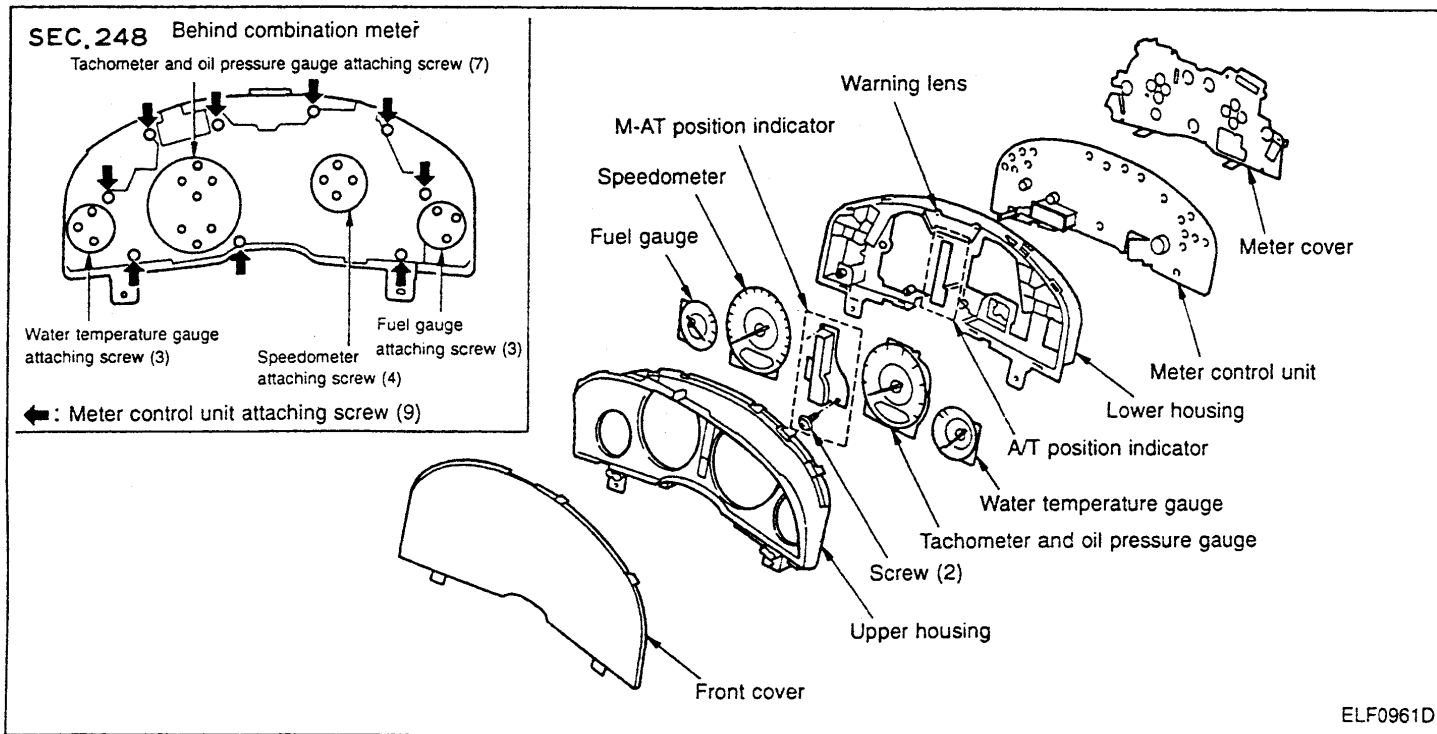

### FLEXIBLE PRINT CIRCUIT (M-AT)

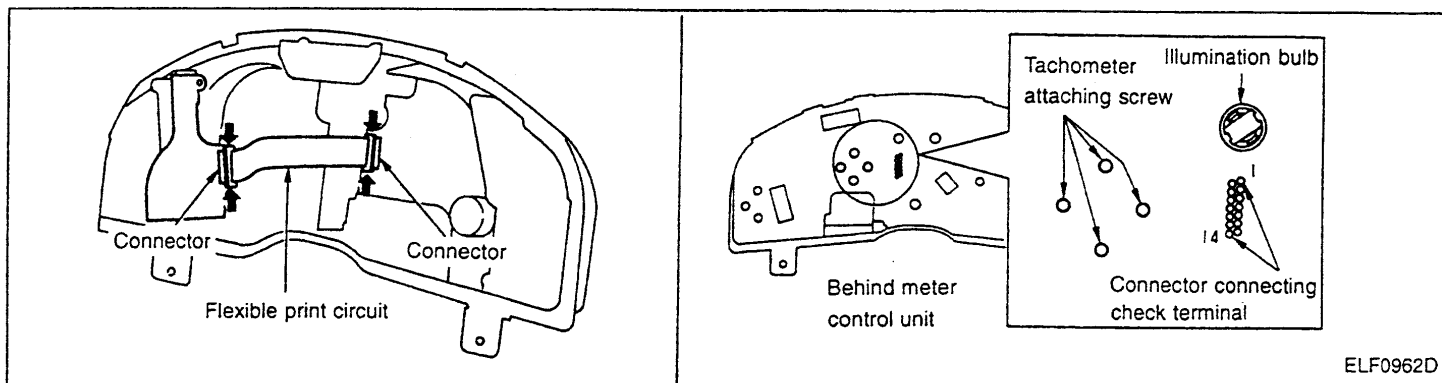

### Removal

1. Pull out the connector while pinching its both ends.
2. Pull flexible print circuit out of the connector.

# METER

## Combination Meter (Cont'd)

### Installation

1. Push the flexible print circuit into the connector and press it down with the connector.
2. Verify that the flexible print circuit is securely connected with the connector.
3. Check that there is continuity between the connector connecting check terminals.

### BEHIND COMBINATION METER AND INTERNAL CIRCUIT

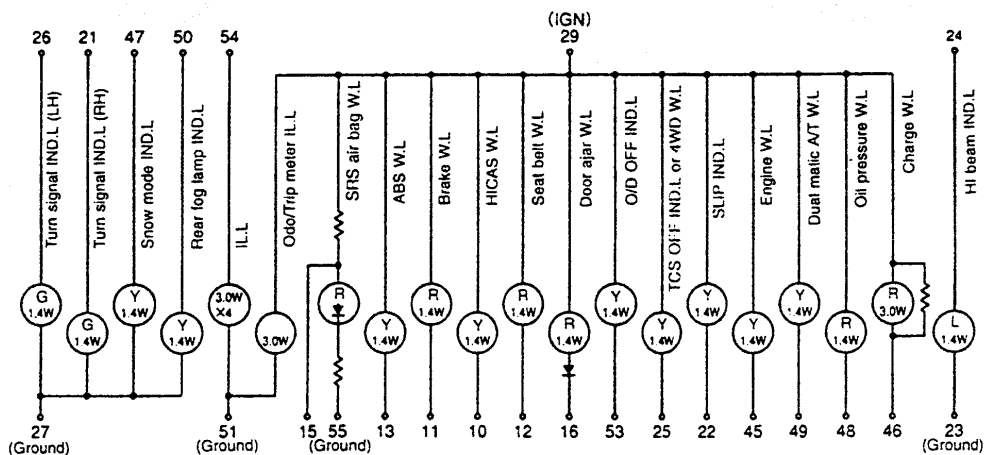
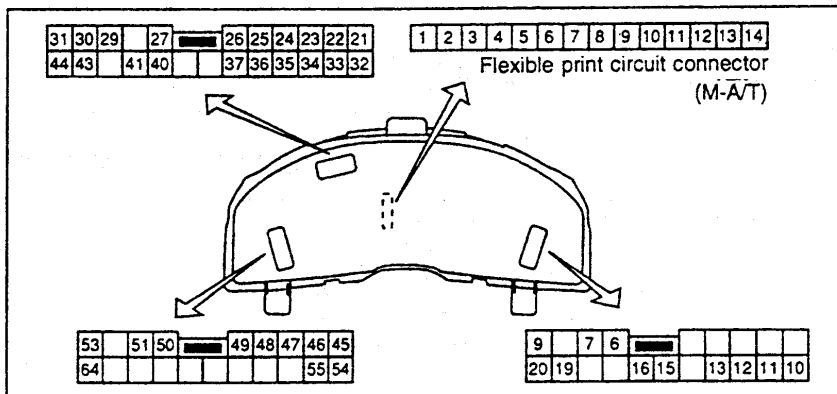
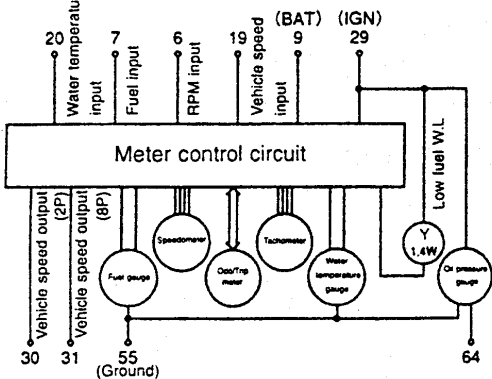

Bulb color:  
G: Green  
L: Blue  
R: Red  
Y: Yellow

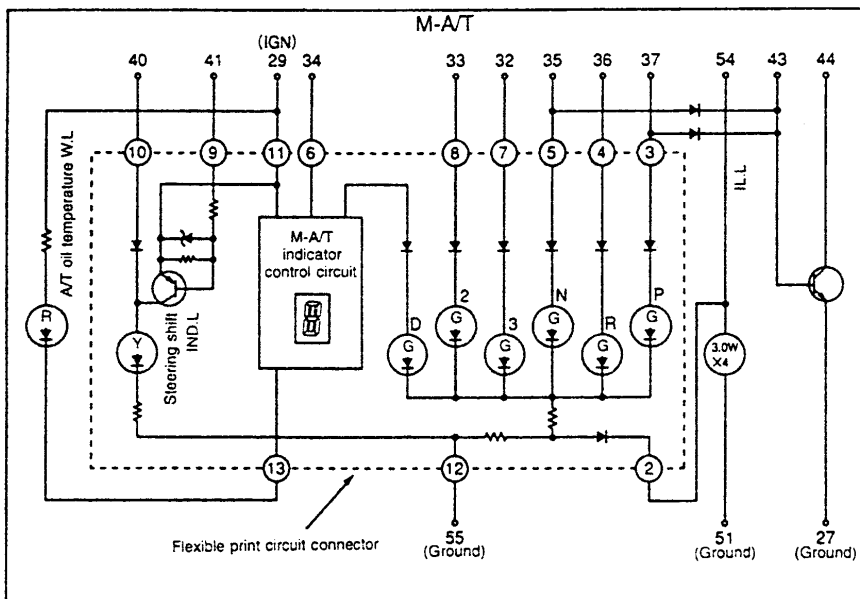
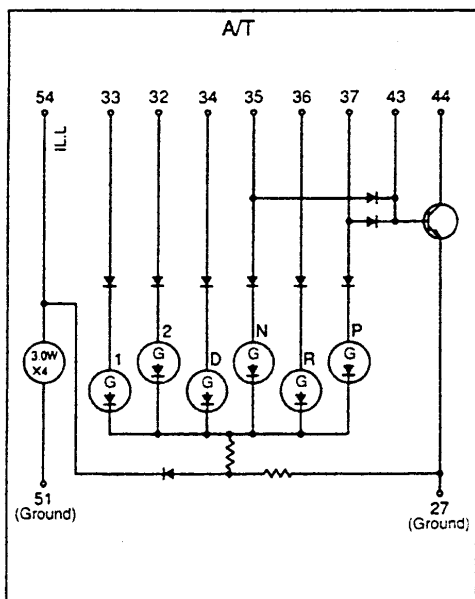

ELF0963D



# METER

## Triple Meter REMOVAL AND INSTALLATION

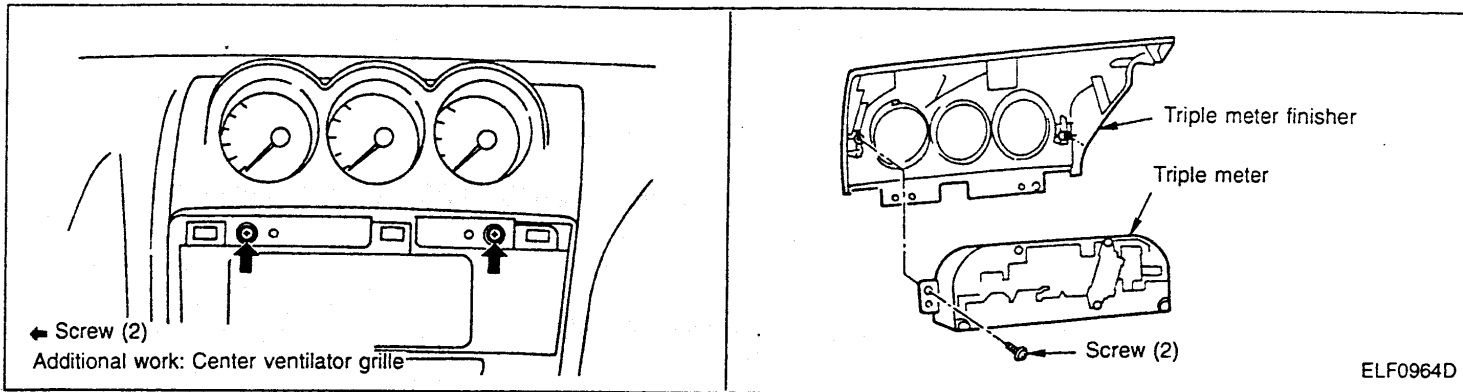

## DISASSEMBLY AND ASSEMBLY

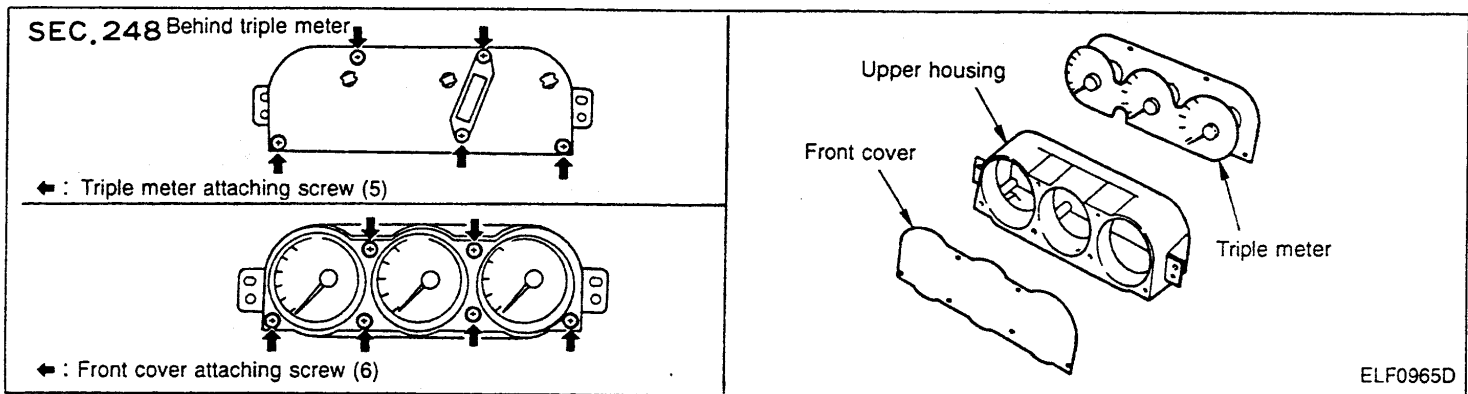

# COMBINATION METER

## System Description

- Speedometer, tachometer, odo/trip meter, fuel gauge, and water temperature gauge are integrally controlled by the control circuit in the meter control unit.
- Diagnosis function has odo/trip meter segment check, low fuel warning lamp check, and continuity check in the meter control circuit and the meters (speedometer, tachometer, fuel gauge, and water temperature gauge).

## Component Parts Location

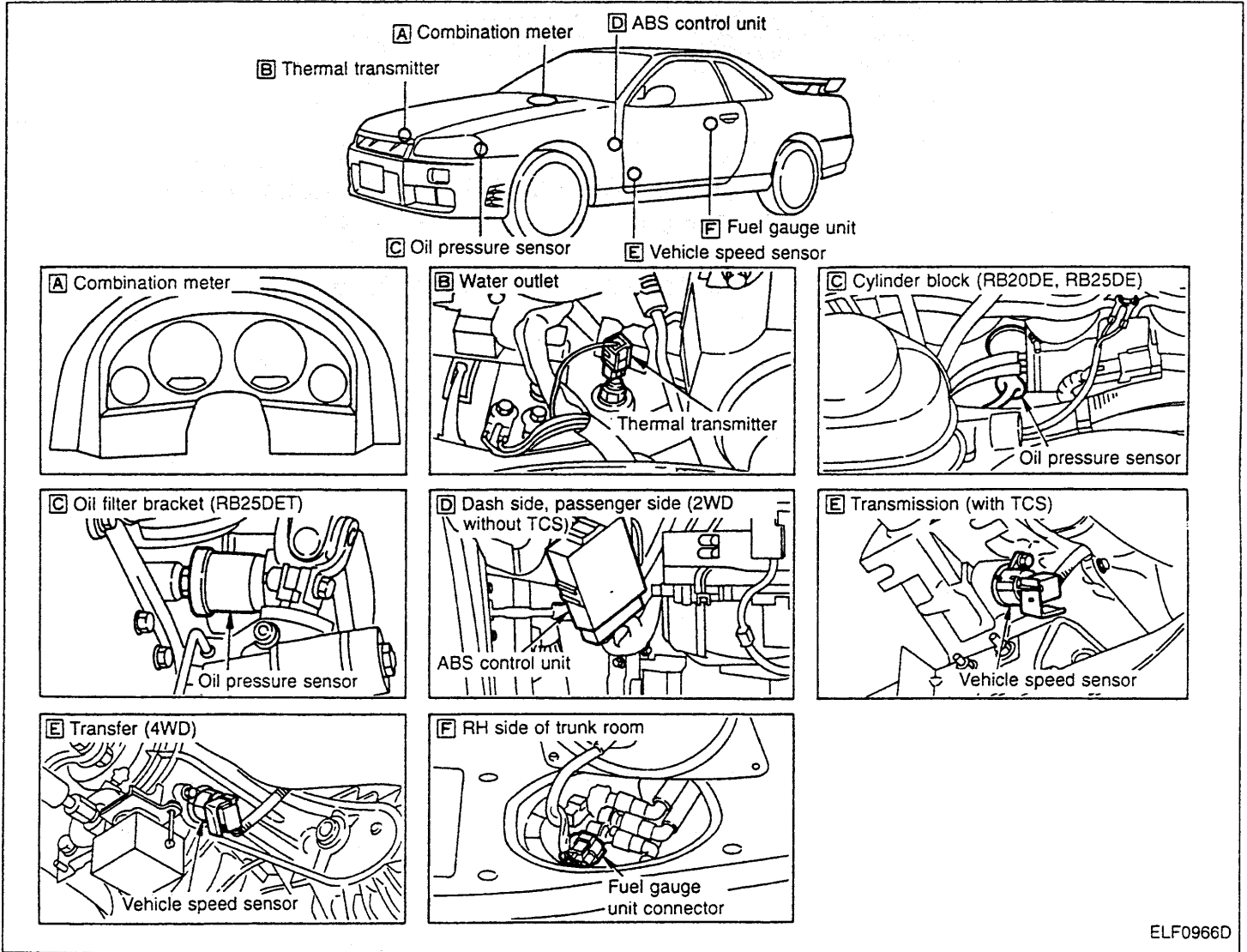

## Diagnosis Function

### SEGMENT CHECK AND LOW FUEL WARNING LAMP CHECK

1. After trip meter is displayed, turn the ignition switch ACC or OFF.
2. Holding down the odo/trip meter switch, turn the ignition switch ON.
3. Verify that 0000.0 km is displayed on the trip meter.
4. Press the odo/trip meter switch 3 times within 5 seconds.
5. All the odo/trip meter segments light up along with low fuel warning lamp.

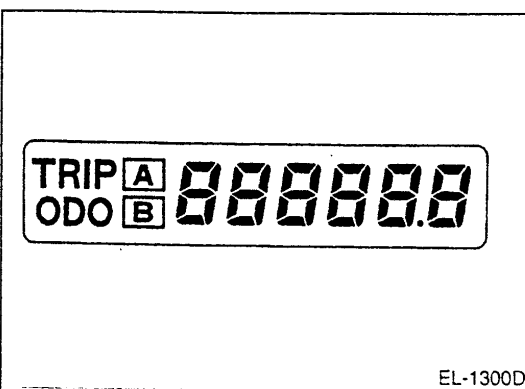

# COMBINATION METER

## Diagnosis Function (Cont'd)

### METER CIRCUIT CHECK

- After the segment check, press the odo/trip meter switch to verify that meters operate as shown below. (Low fuel warning lamp goes off at this point.)

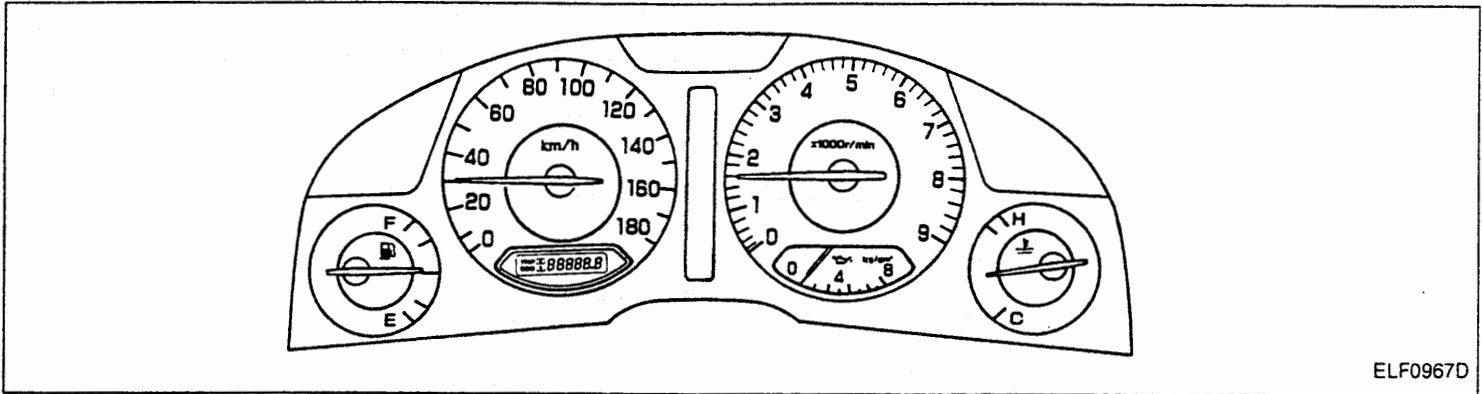

ELF0967D

- It takes 1 minute for the meters to become stable.

### DIAGNOSIS FUNCTION CANCELLATION

Turn the ignition switch ACC or OFF.

### Meter-related Circuit Diagram

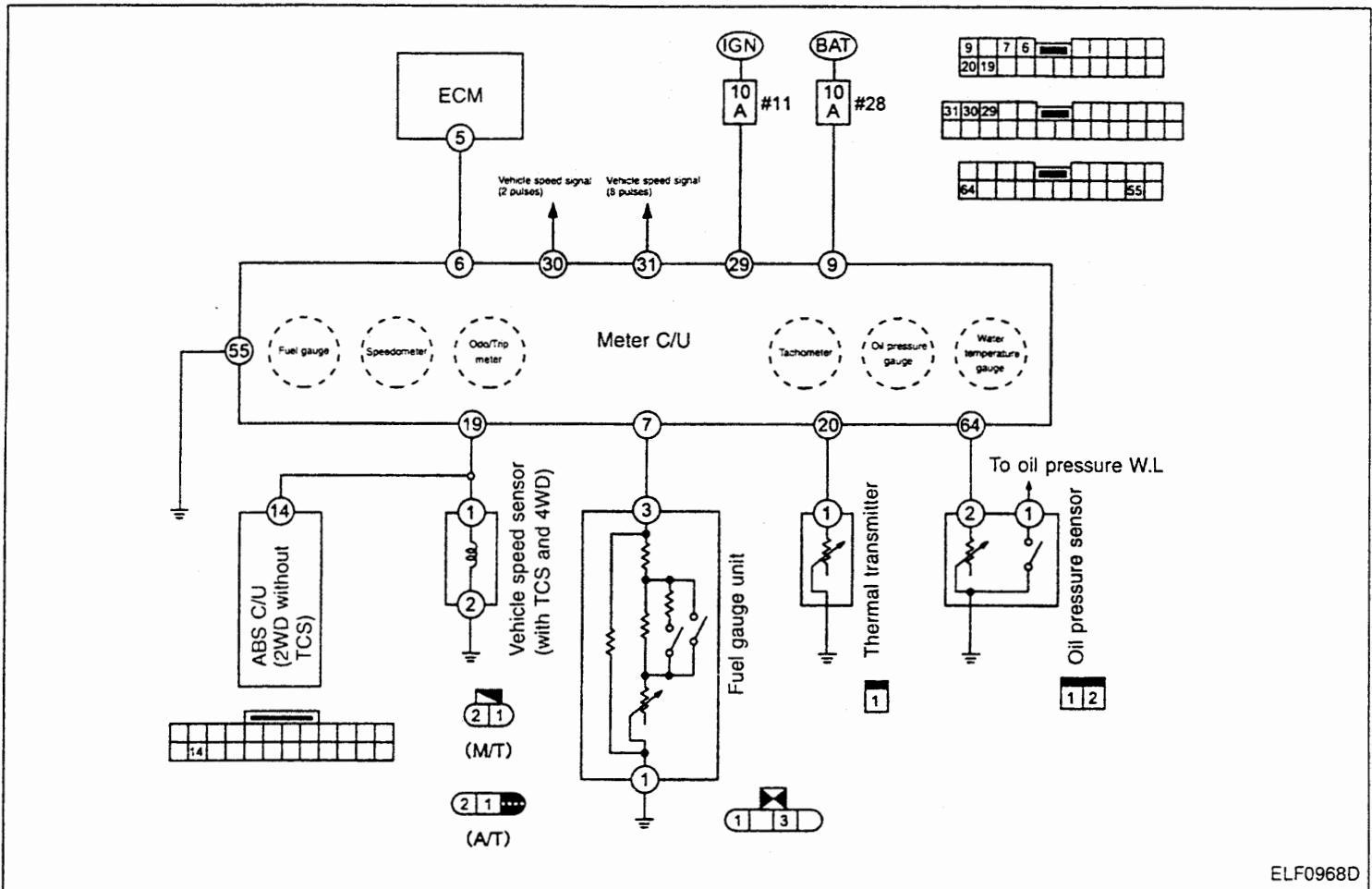

ELF0968D

# COMBINATION METER

## Trouble Diagnoses DIAGNOSTIC PROCEDURE

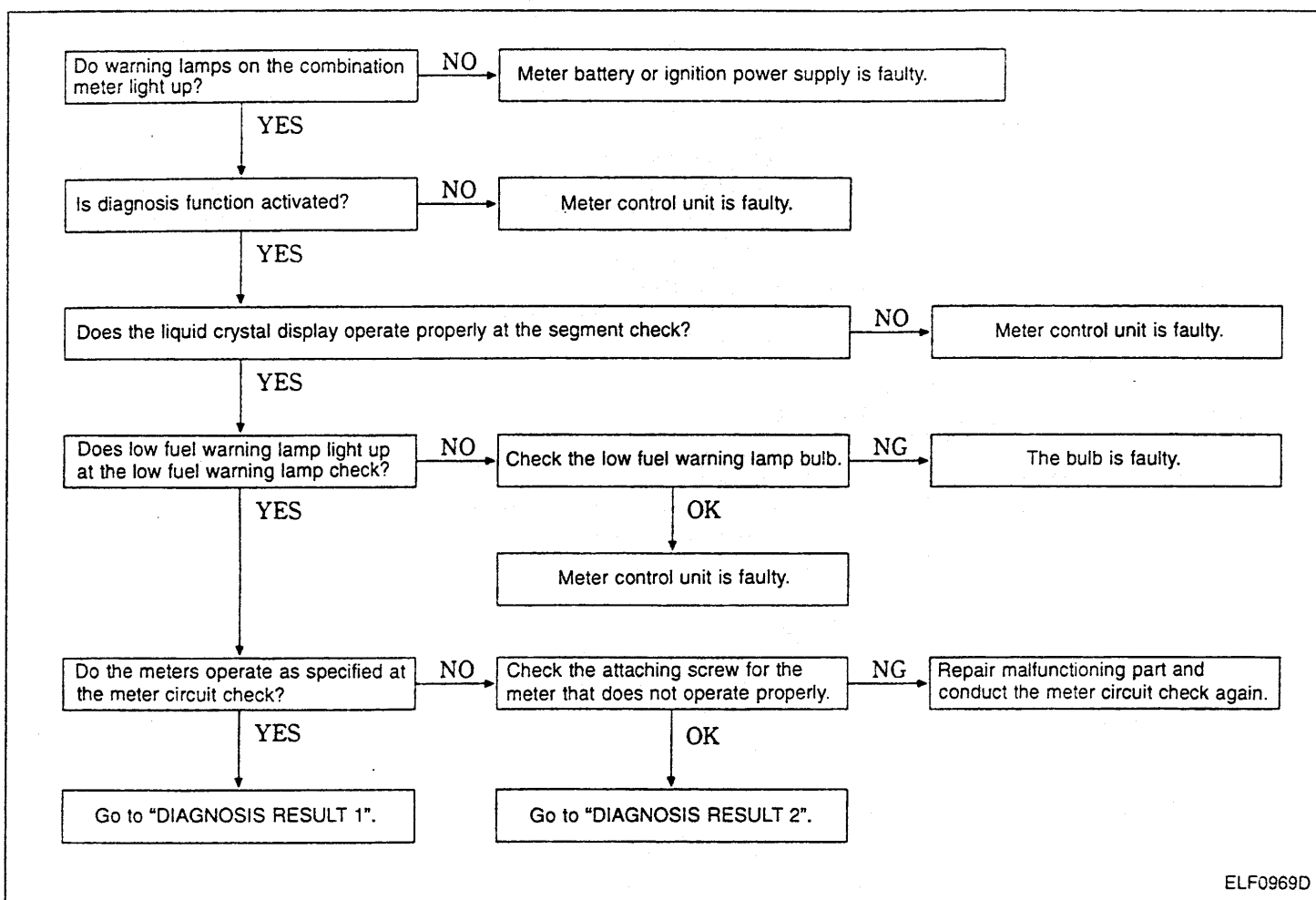

ELF0969D

### DIAGNOSIS RESULT 1

Symptom	Check item	Malfunctioning item
Low fuel warning lamp does not operate properly.	Sensor circuit for the meter (warning lamp) that does not operate properly	NG Sensor or harness for the meter that does not operate properly
Any of tachometer, fuel gauge, and water temperature gauge does not operate properly.		OK Meter control unit
More than one meter out of tachometer, fuel gauge, and water temperature gauge do not operate properly.	—	Meter control unit
Speedometer and odo/trip meter do not operate properly.	Vehicle speed input signal (with TCS)	NG Vehicle speed sensor or harness
		OK Meter control unit
	Perform "VEHICLE SPEED INPUT SIGNAL DIAGNOSIS" on the next page. (without TCS)	—

### DIAGNOSIS RESULT 2

Symptom	Check item	Malfunctioning item
Any of speedometer, tachometer, fuel gauge, and water temperature gauge does not operate properly.	Resistance of the meter that does not operate properly	NG Meter that does not operate properly
		OK Meter control unit
More than one meter out of speedometer, tachometer, fuel gauge, and water temperature gauge do not operate properly.	—	Meter control unit

# COMBINATION METER

## Trouble Diagnoses (Cont'd)

### VEHICLE SPEED INPUT SIGNAL DIAGNOSIS

#### WARNING LAMP CHECK

Does ABS warning lamp remain ON with ignition switch ON?

YES

Perform ABS self-diagnosis and check faulty circuit. Refer to BR section ("ABS SYSTEM").

NO

**A**

#### HARNESS CHECK

Disconnect ABS control unit connector (TK24) and meter connector (TK20 Brown).

Terminals No. 19 - 24:

Continuity exists.

Terminal No. 19 and ground:

No continuity

NG

ABS control unit to meter harness is faulty.

OK

**B**

#### VEHICLE SPEED INPUT SIGNAL CHECK 1

Connect meter connector (TK20 Brown).

Terminal No. 19 and ground:

Approx. 9V

NG

Meter control unit is faulty.

OK

**C**

#### VEHICLE SPEED INPUT SIGNAL CHECK 2

- Connect ABS control unit connector (TK24).

- Start the engine and drive the vehicle.

Terminal No. 19 and ground:

Specification

Refer to "Combination Meter Input/Output Signal Specifications" on the next page.

NG

Perform ABS self-diagnosis and check faulty circuit. Refer to BR section ("ABS SYSTEM").

OK

Meter control unit is faulty.

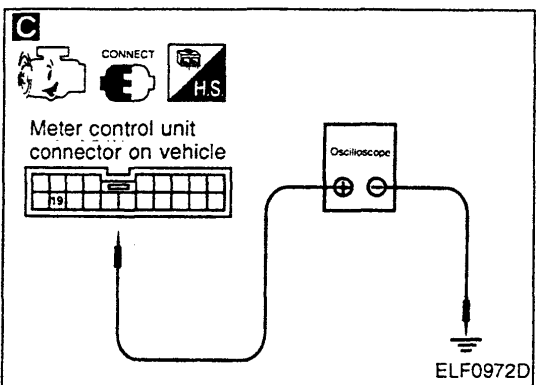
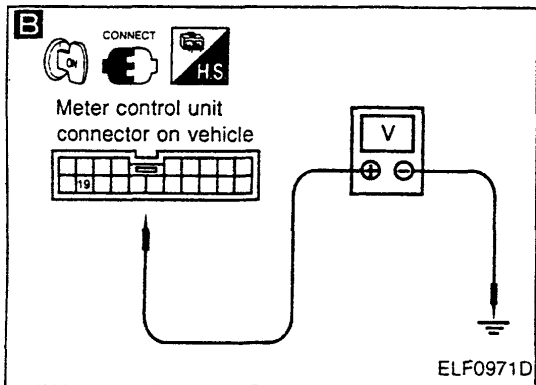
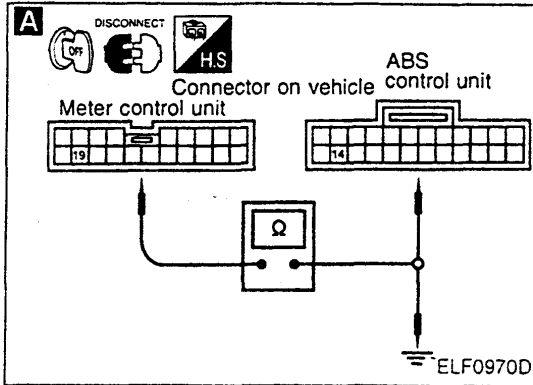

# COMBINATION METER

## Combination Meter Input/Output Signal Specifications

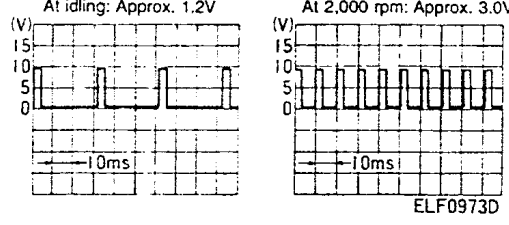
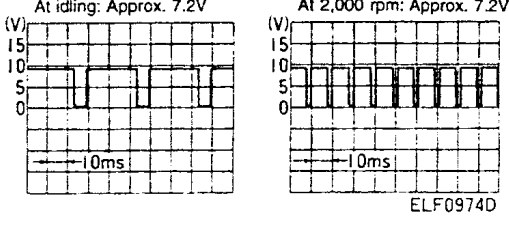
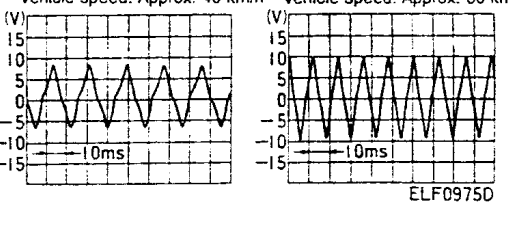
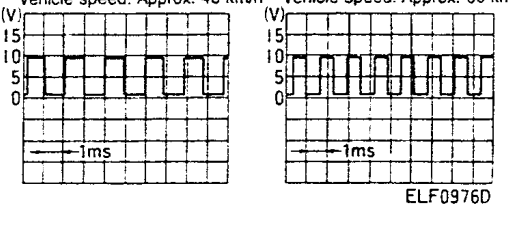
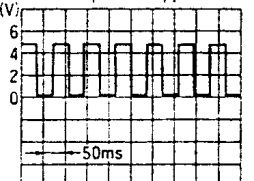
Terminal No.		Signal name	Measuring condition		Specification
+	-		Ignition switch	Operation or condition	
6	Body ground	Tachometer drive signal	ON	Disconnect ECM connector.	Approx. 8 - 10V
				Engine is idling or running at 2,000 rpm.	<p style="text-align: center;">RB20DE, RB25DE</p> <p style="text-align: center;">At idling: Approx. 1.2V      At 2,000 rpm: Approx. 3.0V</p>  <p style="text-align: right;">ELF0973D</p>
				<p style="text-align: center;">RB25DET</p> <p style="text-align: center;">At idling: Approx. 7.2V      At 2,000 rpm: Approx. 7.2V</p>  <p style="text-align: right;">ELF0974D</p>	
7		Fuel gauge signal	—	—	Refer to "Component Parts Inspection" (EL-27).
9		Battery	OFF	—	Approx. 12V
19	Body ground	Vehicle speed input signal	ON	Speedometer is in operation. (Vehicle speed is approx. 40 km/h.) (Vehicle speed is approx. 60 km/h.)	<p style="text-align: center;">With TCS</p> <p style="text-align: center;">Vehicle speed: Approx. 40 km/h      Vehicle speed: Approx. 60 km/h</p>  <p style="text-align: right;">ELF0975D</p>
					<p style="text-align: center;">Without TCS</p> <p style="text-align: center;">Vehicle speed: Approx. 40 km/h      Vehicle speed: Approx. 60 km/h</p>  <p style="text-align: right;">ELF0976D</p>
20		Thermal transmitter signal	—	—	Refer to "Component Parts Inspection" (EL-27).
29		Ignition power supply	ON	—	Approx. 12V
30	Body ground	Vehicle speed signal (2 pulses)	ON	Speedometer is not in operation.	Approx. 4.8V or 0V
				Speedometer is in operation. (Vehicle speed is approx. 40 km/h.)	<p style="text-align: center;">Vehicle speed is approx. 40 km/h: Approx. 2.4V</p>  <p style="text-align: right;">ELF0977D</p>

Voltage of the upper part of the wave form indicates the value checked with analogue circuit tester.

GI

EC

AT

BR

ST

RS

HA

EL

SD

# COMBINATION METER

## Combination Meter Input/Output Signal Specifications (Cont'd)

Terminal No.		Signal name	Measuring condition		Specification
+	-		Ignition switch	Operation or condition	
31	Body ground	Vehicle speed signal (8 pulses)	ON	Speedometer is not in operation.	Approx. 4.8V or 0V
				Speedometer is in operation. (Vehicle speed is approx. 40 km/h.)	
55		Ground	ON	—	Approx. 0V
64		Oil pressure sensor signal	—	—	Refer to "Component Parts Inspection" (EL-28).

Voltage of the upper part of the wave form indicates the value checked with analogue circuit tester.

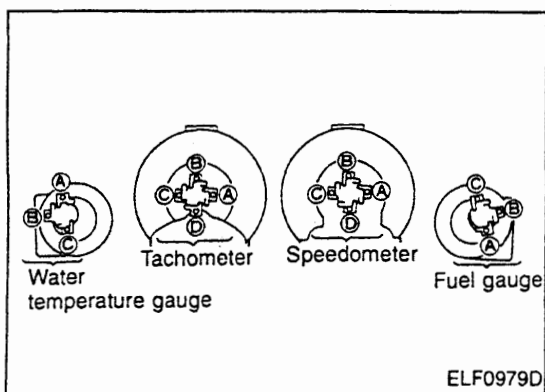

### Component Parts Inspection

#### SPEEDOMETER, TACHOMETER, FUEL GAUGE AND WATER TEMPERATURE GAUGE

Remove each meter from the meter control unit and check the resistance between the terminals as shown below.

Checking terminal		Resistance $\Omega$
Speedometer and tachometer	Fuel gauge and water temperature gauge	
A - C	A - C	Approx. 190 - 260
B - D	B - C	Approx. 230 - 310

#### OIL PRESSURE GAUGE

- Disconnect oil pressure sensor connector.
- Turn the ignition switch ON, and connect test lamp and lead wire with the meter attaching screw as shown left. Check the gauge indication.

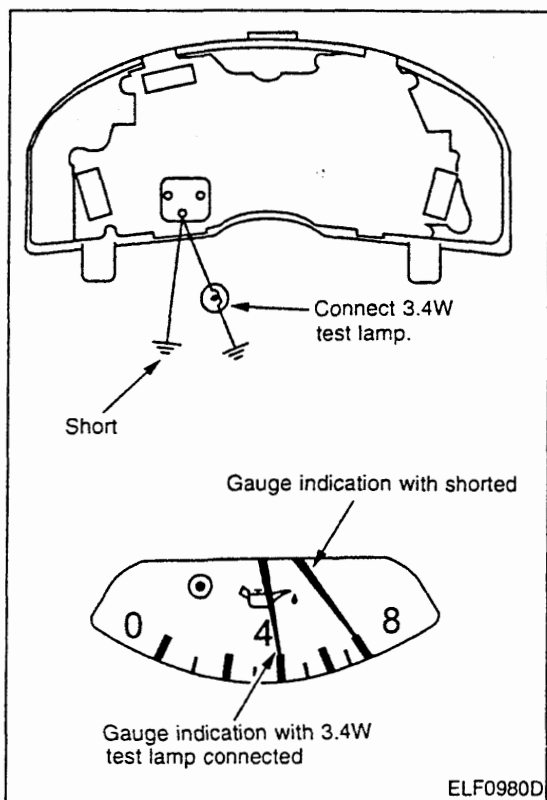

# COMBINATION METER

## Component Parts Inspection (Cont'd)

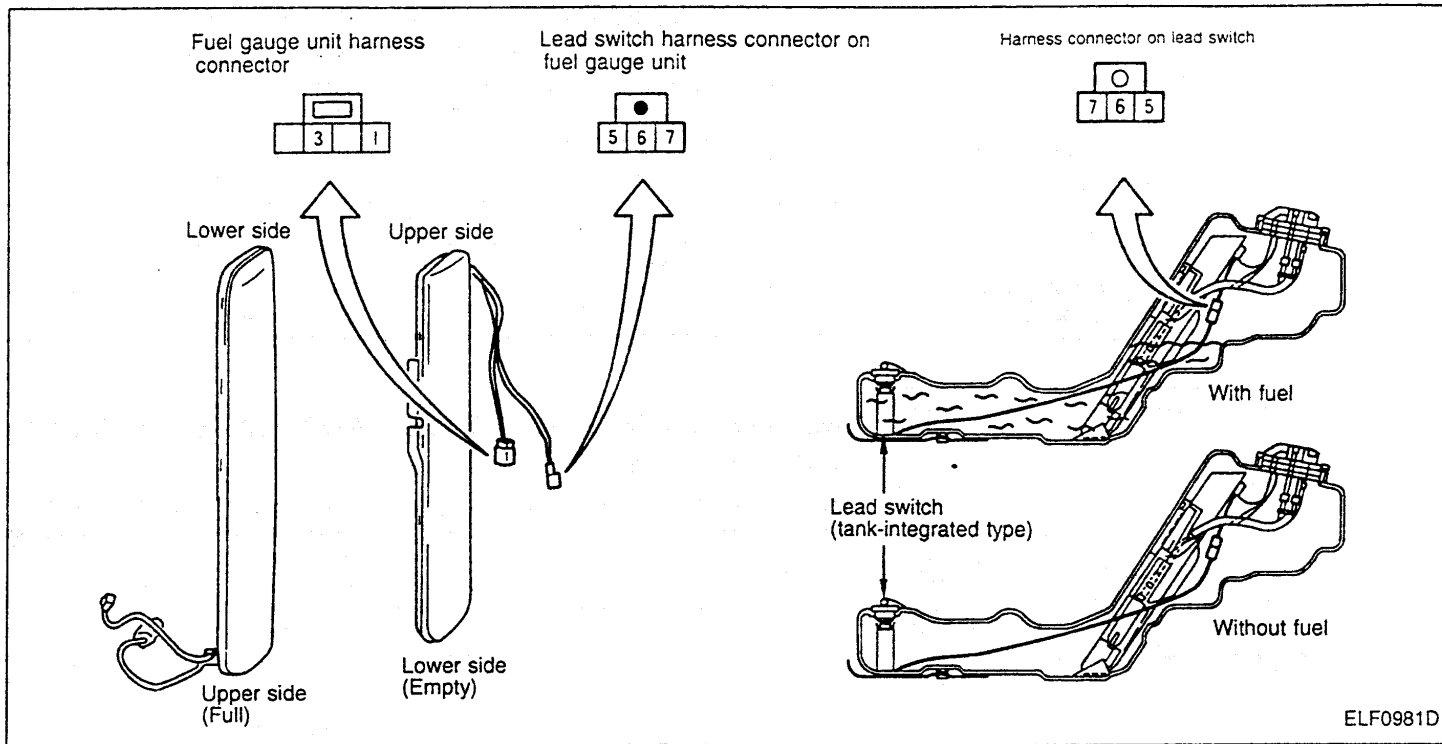

### FUEL GAUGE UNIT

- Remove fuel gauge unit from the vehicle.
- Check the gauge resistance on the gauge with the fuel gauge at Empty and then Full.

Terminal No.	Float position	Resistance $\Omega$
1 - 3	Full	Approx. 6 max.
	Empty	Approx. 80 min.

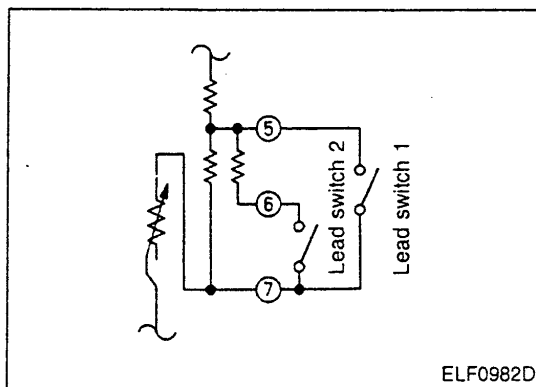

### LEAD SWITCH

- Remove fuel gauge unit from the vehicle.
- Check continuity between terminals on the lead switches in the tank.

Terminal No.	Condition	Continuity
5 - 7 6 - 7	With fuel	Yes
	Without fuel	No

- There is no continuity when approx. 2 $\ell$  of fuel is left in the sub fuel tank.

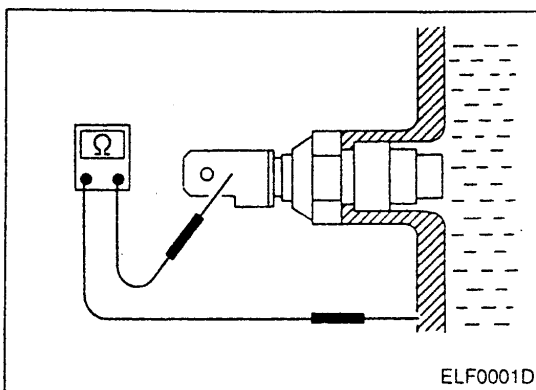

### THERMAL TRANSMITTER

- When the engine has warmed up to approx. 80°C, measure resistance between thermal transmitter and body ground.  
Specification: Approx. 76 - 90 $\Omega$

GI  
EC  
AT  
BR  
ST  
RS  
HA

EL

SD



# COMBINATION METER

## Component Parts Inspection (Cont'd)

- If the measured resistance is out of the specification with the thermal transmitter on vehicle, remove the thermal transmitter from the vehicle and measure resistance as shown left.

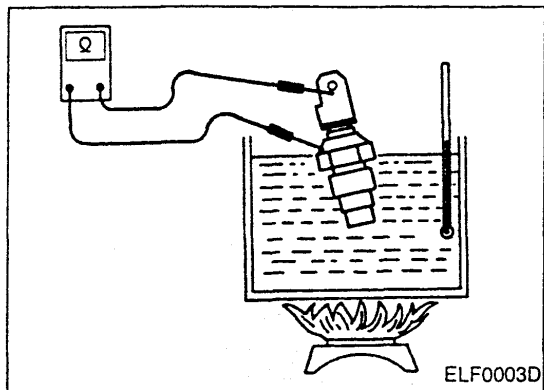

Water temperature °C	Resistance Ω
Approx. 60	Approx. 170 - 210
Approx. 65	Approx. 140 - 170
Approx. 80	Approx. 76 - 90
Approx. 100	Approx. 47 - 53

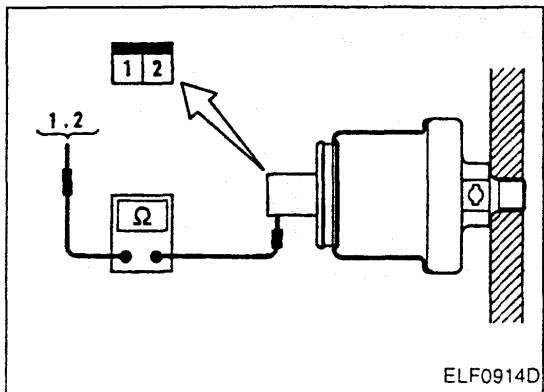

## OIL PRESSURE SENSOR (OIL PRESSURE WARNING LAMP SWITCH)

Check continuity between oil pressure sensor and body ground.

Terminal No.	Condition	Oil pressure MPa (kg/cm <sup>2</sup> )	Continuity
1	Engine is stopped.	Less than 0.01 - 0.024 (0.1 - 0.25)	Yes
	Engine is started.	More than 0.01 - 0.024 (0.1 - 0.25)	No

## OIL PRESSURE SENSOR

Check the resistance between the oil pressure sensor and body ground.

Terminal No.	Oil pressure MPa (kg/cm <sup>2</sup> )	Resistance Ω
2	0.1 (1.0)	Approx. 42 - 50
	0.2 (2.0)	Approx. 37 - 45
	0.39 (4.0)	Approx. 25 - 35

# TRIPLE METER

## Special Service Tool

Tool number Tool name	Description
EG1513 0000 Handy vacuum pump	Boost sensor check 

ZZA0062D

## Component Parts Location

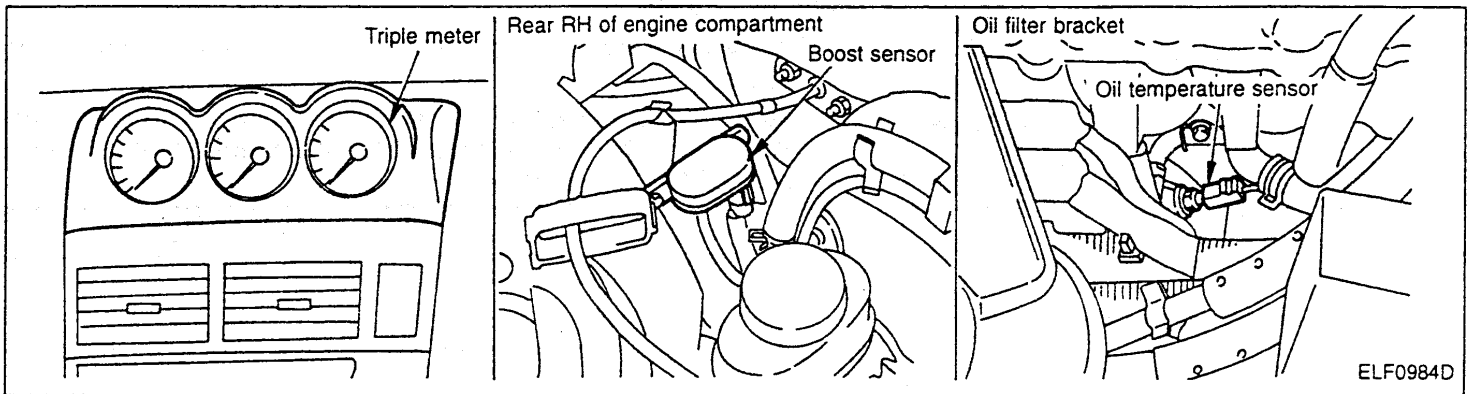

ELF0984D

## Circuit Diagram

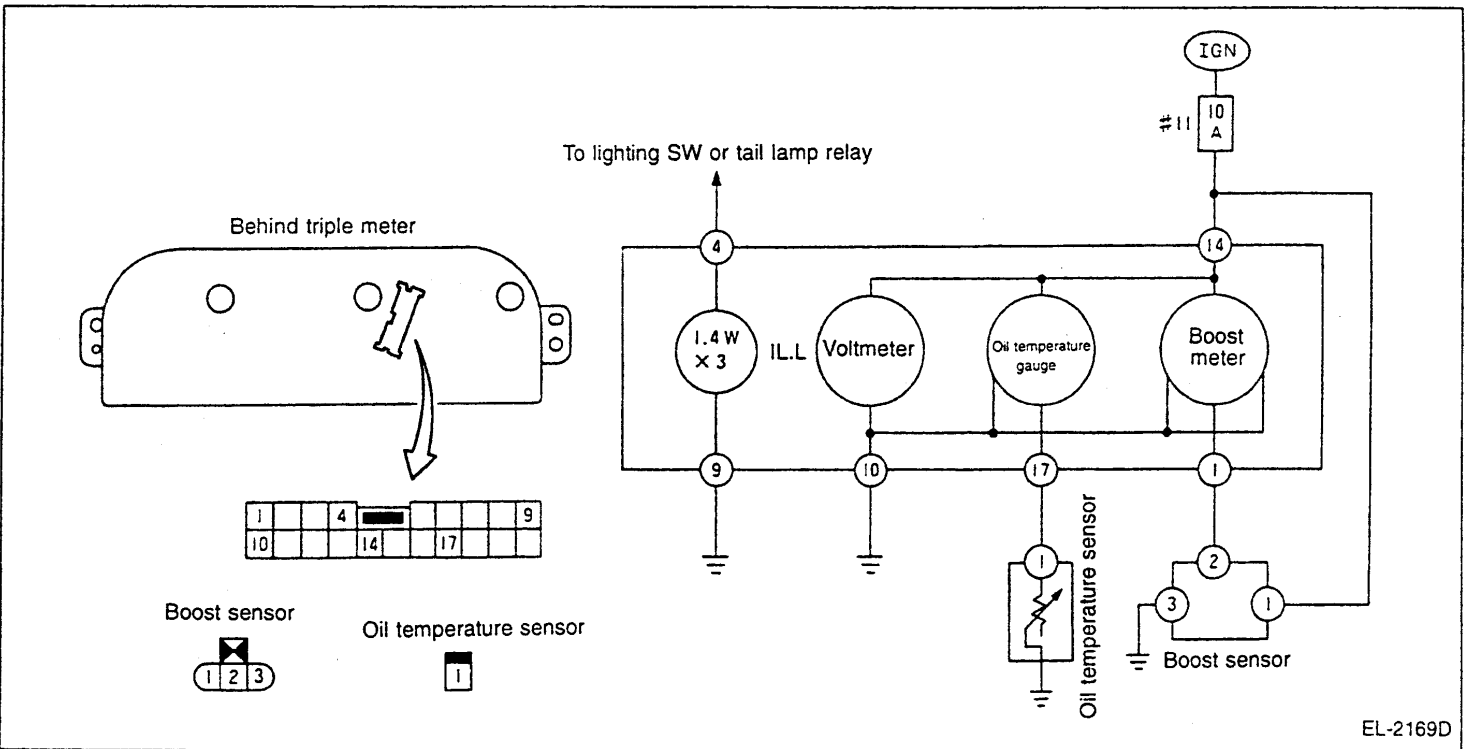

GI

EC

AT

BR

ST

RS

HA

EL

SD

# TRIPLE METER

## Triple Meter Input/Output Signal Specifications

Terminal No.	Signal name	Measuring condition		Specification
		Ignition switch	Operation or condition	
1	Boost sensor signal	ON	0 mmHg	Approx. 2.2V
4	Illumination power supply	OFF	Lighting switch: 1ST	Approx. 12V
9	Illumination ground	ON	—	Approx. 0V
10	Ground	ON	—	Approx. 0V
14	Ignition power supply	ON	—	Approx. 12V
17	Oil temperature sensor signal	—	—	Refer to "Component Parts Inspection".

## Component Parts Inspection

### BOOST SENSOR

- Connect handy vacuum pump (special service tool) to boost sensor.
- Apply battery voltage (12V) to terminal No. 1 and connect terminal No. 3 to the ground. Then, measure voltage between terminal No. 2 and the ground.

Pressure kPa (mmHg)	Voltage V
Atmospheric pressure	Approx. 2.2
-47 (-350)	Approx. 1.4

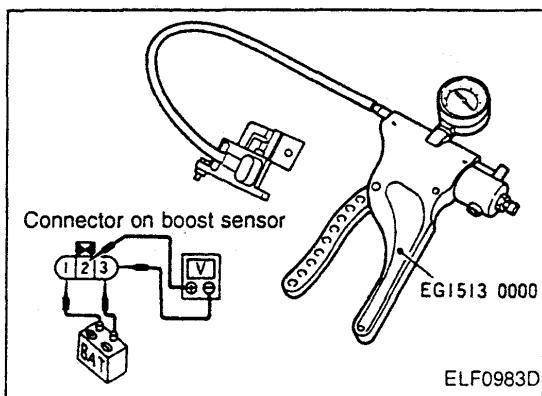

### OIL TEMPERATURE SENSOR

Remove oil temperature sensor from the vehicle and measure resistance as shown left.

Oil temperature °C	Resistance Ω
Approx. 70	Approx. 92.0
Approx. 90	Approx. 48.5
Approx. 110	Approx. 27.3
Approx. 130	Approx. 16.3
Approx. 150	Approx. 10.2

#### CAUTION:

Always use new engine oil.

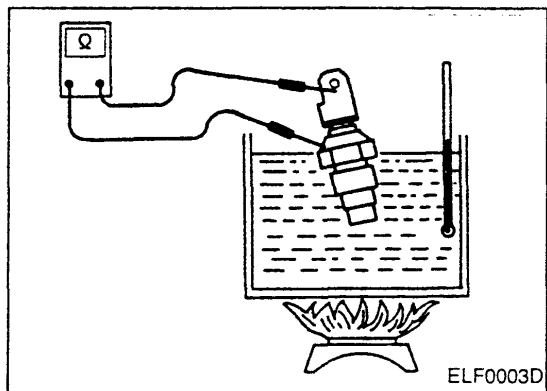

## Component Parts Location

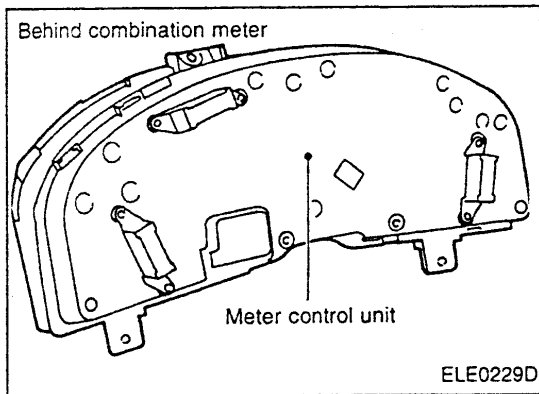

## Circuit Diagram

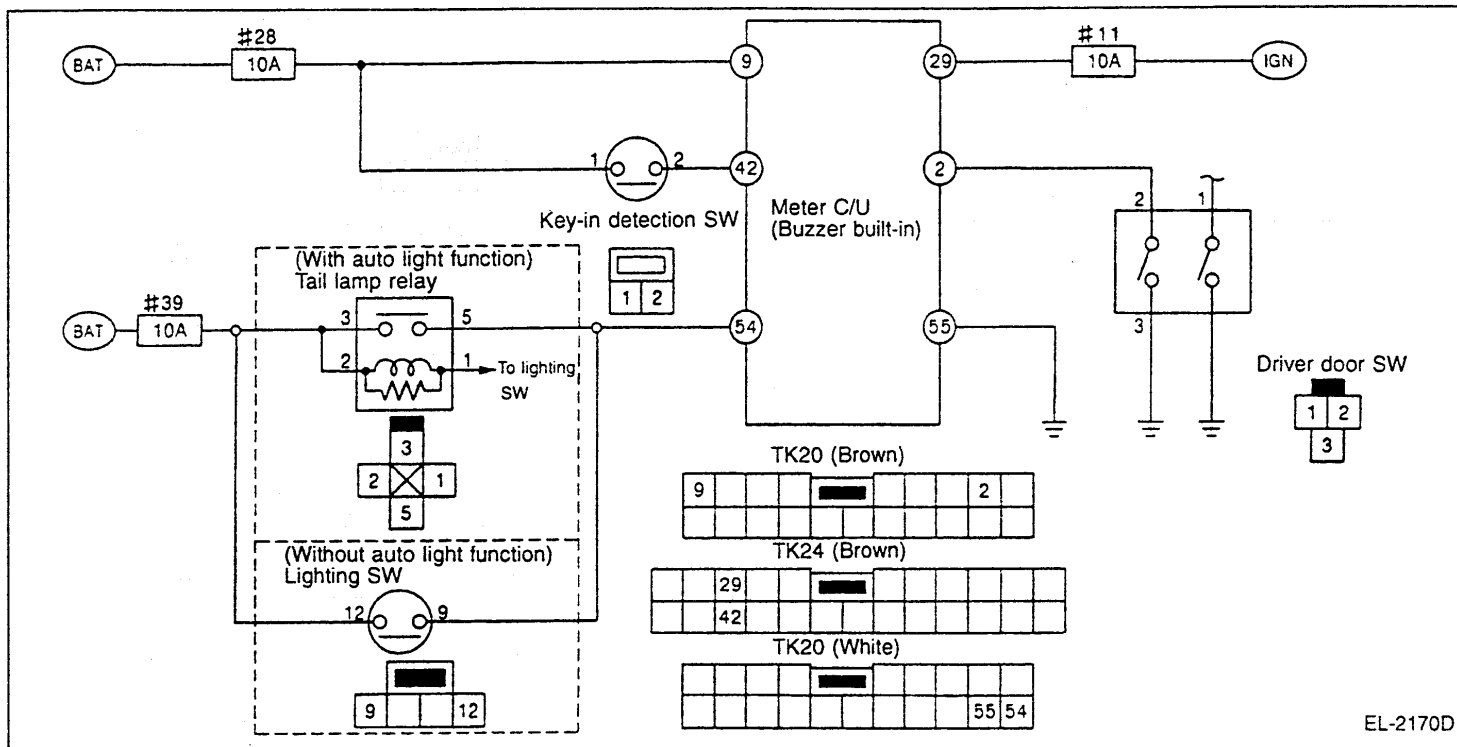

## Meter Control Unit Input/Output Signal Specifications

Terminal No.	Signal name	Measuring condition		Specification	
		Ignition switch	Measuring method		
2	Driver door switch signal	OFF	Driver door switch	ON (Open)	Approx. 0V
				OFF (Closed)	Approx. 12V
9	Battery	OFF	—	Approx. 12V	
29	Ignition power supply	ON	—	Approx. 12V	
42	Key-in detection switch signal	OFF	Remove the ignition key.	Approx. 0V	
			Insert the ignition key.	Approx. 12V	
54	Lighting switch signal	OFF	Lighting switch: 1ST	ON	Approx. 12V
				OFF	Approx. 0V
55	Ground	ON	—	Approx. 0V	

# FRONT WIPER

## Component Parts Location

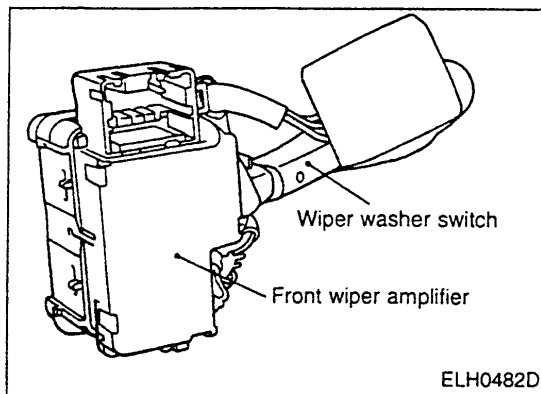

## Circuit Diagram

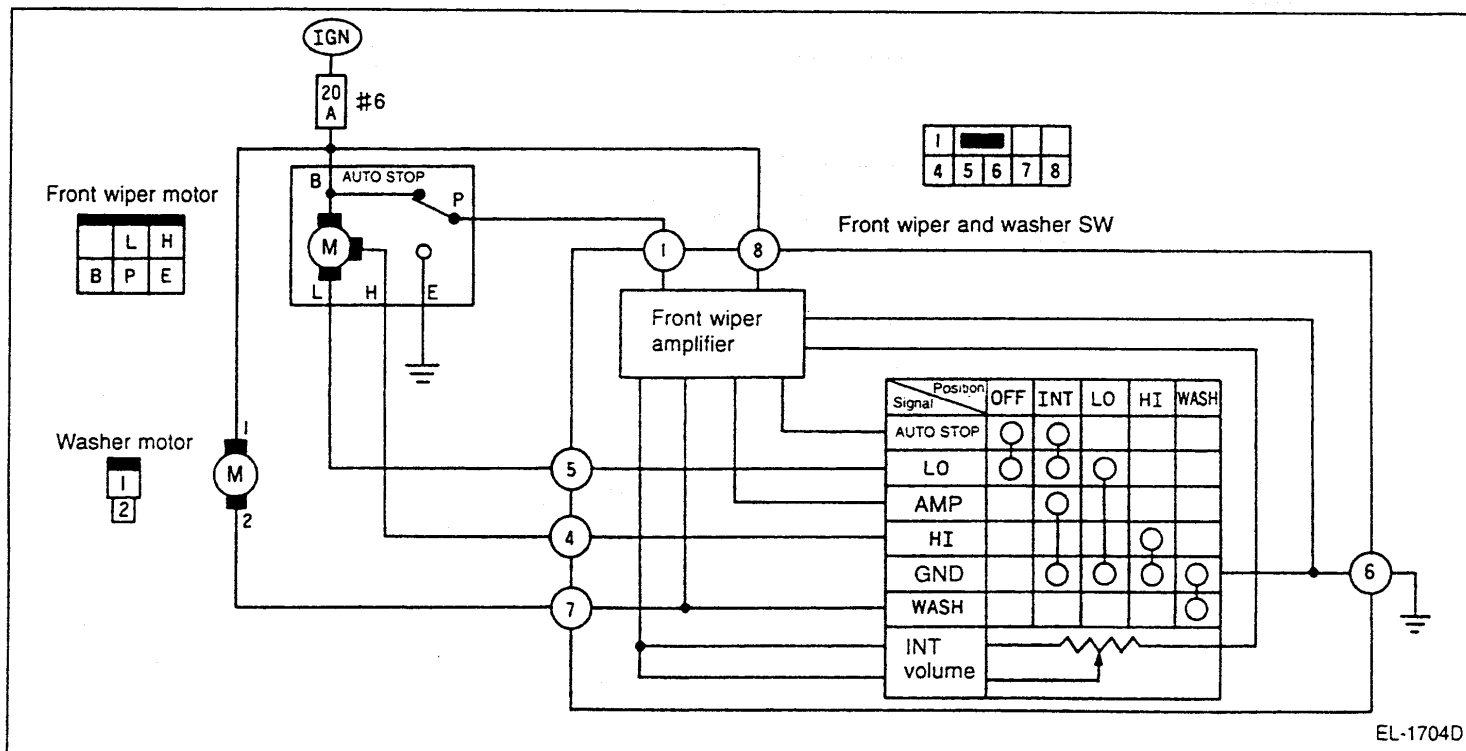

## Front Wiper Input/Output Signal Specifications

Terminal No.	Signal name	Measuring condition		Specification				
		Ignition switch	Operation					
1	Wiper motor position detection signal	ON	Wiper switch: LO position	<p>(Reference)</p>				
4	Wiper motor HI signal	ON	Wiper switch	<table border="1"> <tr> <td>OFF</td> <td>Approx. 12V</td> </tr> <tr> <td>HI</td> <td>Approx. 0V</td> </tr> </table>	OFF	Approx. 12V	HI	Approx. 0V
OFF	Approx. 12V							
HI	Approx. 0V							
5	Wiper motor LO signal	ON	Wiper switch	<table border="1"> <tr> <td>OFF</td> <td>Approx. 12V</td> </tr> <tr> <td>LO</td> <td>Approx. 0V</td> </tr> </table>	OFF	Approx. 12V	LO	Approx. 0V
OFF	Approx. 12V							
LO	Approx. 0V							
6	Ground	ON	—	Approx. 0V				
7	Washer operation detection signal	ON	Washer motor is in operation.	Approx. 0V				
			Washer motor is not in operation.	Approx. 12V				
8	Ignition power supply	ON	—	Approx. 12V				

# REAR WIPER

## Component Parts Location

Rear of suspension tower (RH)

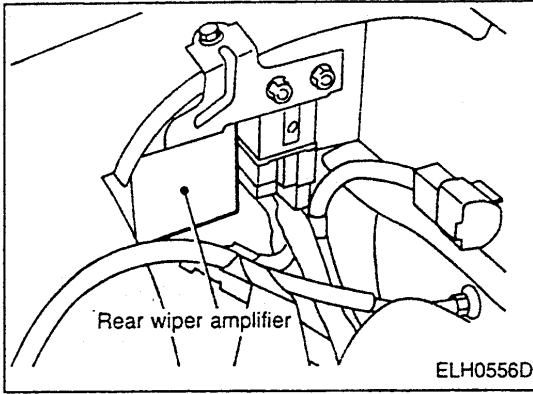

## Circuit Diagram

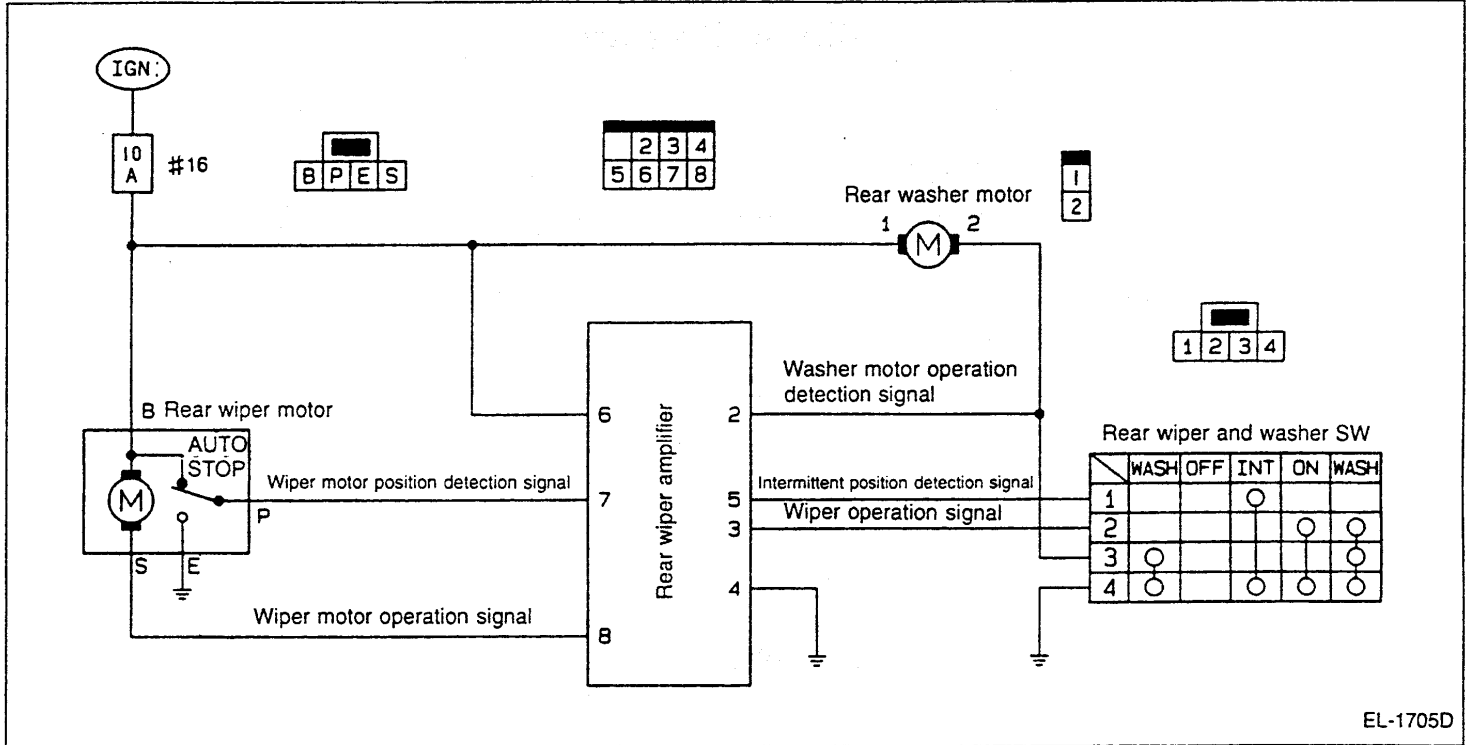

## Rear Wiper Amplifier Input/Output Signal Specifications

Terminal No.	Signal name	Measuring condition		Specification
		Ignition switch	Operation	
2	Washer motor operation detection signal	ON	Washer motor is in operation.	Approx. 0V
			Washer motor is not in operation.	Approx. 12V
3	Wiper operation signal	ON	Wiper motor is in operation.	Approx. 0V
			Wiper motor is not in operation.	Approx. 12V
4	Ground	ON	—	Approx. 0V
5	Intermittent position detection signal	ON	Wiper switch: INT	Approx. 0V
			Other than INT	Approx. 12V
6	ACC power supply	ON	—	Approx. 12V
8	Wiper motor operation signal	ON	Wiper switch: INT position	<p>ELH0345D (Reference)</p>

# REAR DEFOGGER AND HEATER MIRROR

## Component Parts Location

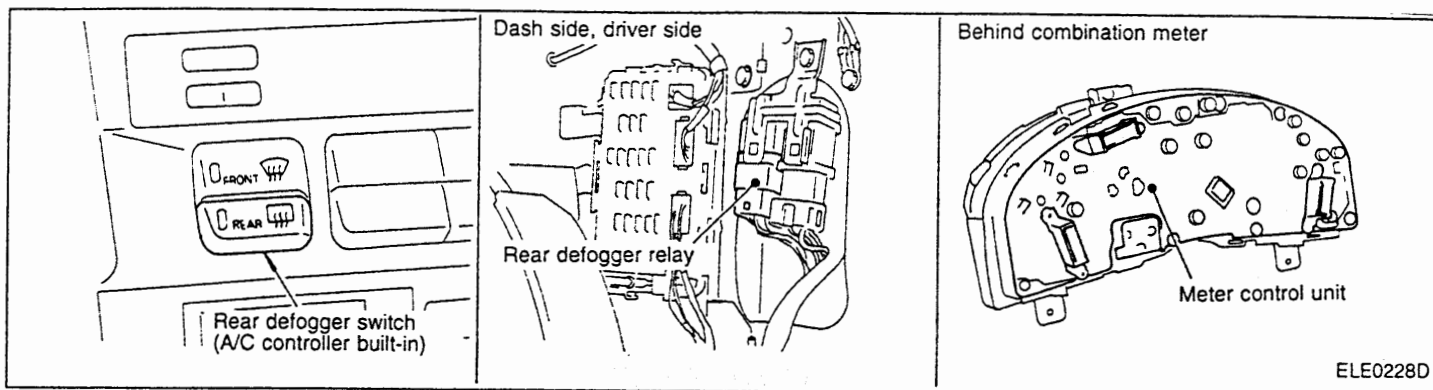

## Circuit Diagram

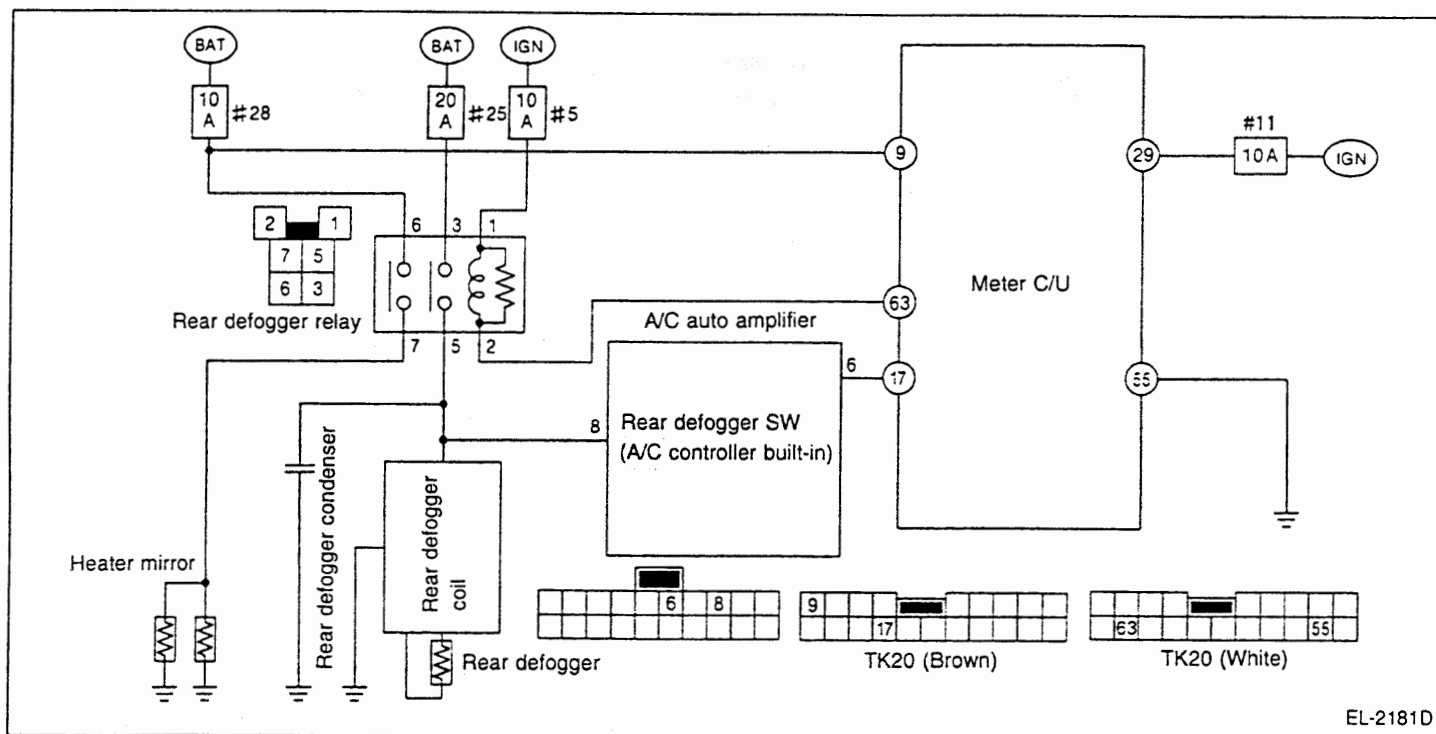

## Meter Control Unit Input/Output Signal Specifications

Terminal No.	Signal name	Measuring condition		Specification	
		Ignition switch	Operation		
9	Battery	OFF	—	Approx. 12V	
17	Rear defogger switch signal	OFF	Rear defogger switch	ON (with switch pressed)	Approx. 0V
				OFF (regardless of connection of A/C auto amplifier)	Approx. 5V
29	Ignition power supply	ON	—	Approx. 12V	
55	Ground	ON	—	Approx. 0V	
63	Rear defogger relay control signal	ON	Rear defogger switch	ON	Approx. 0V*
				OFF	Approx. 12V

**NOTE:** Refer to "Auto Amplifier Input/Output Signal Specifications".

\*: It changes to approximately 12V when 15 minutes or 30 minutes pass after the ignition switch is turned ON.

# WIPER DEICER

## Component Parts Location

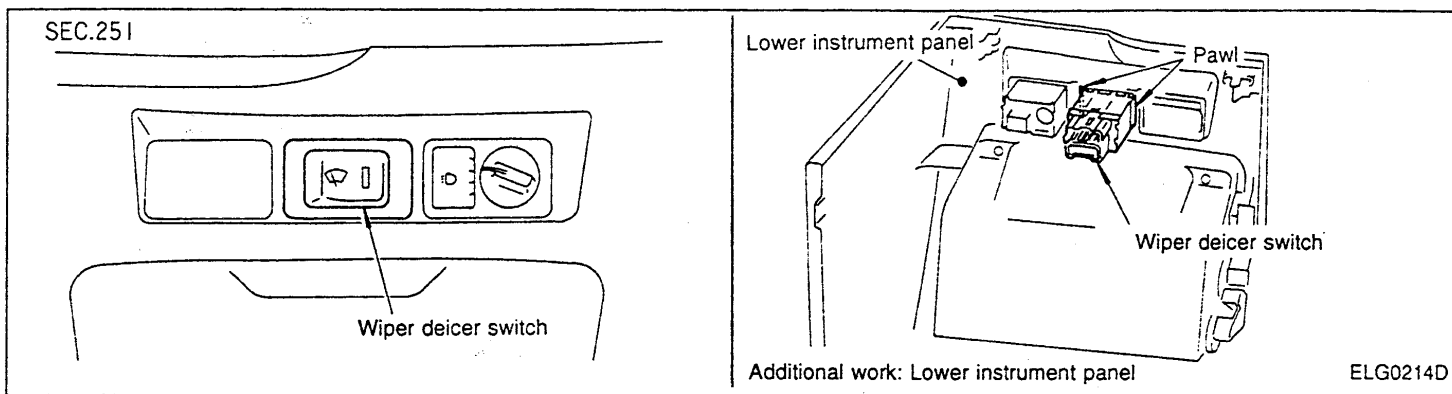

## Circuit Diagram

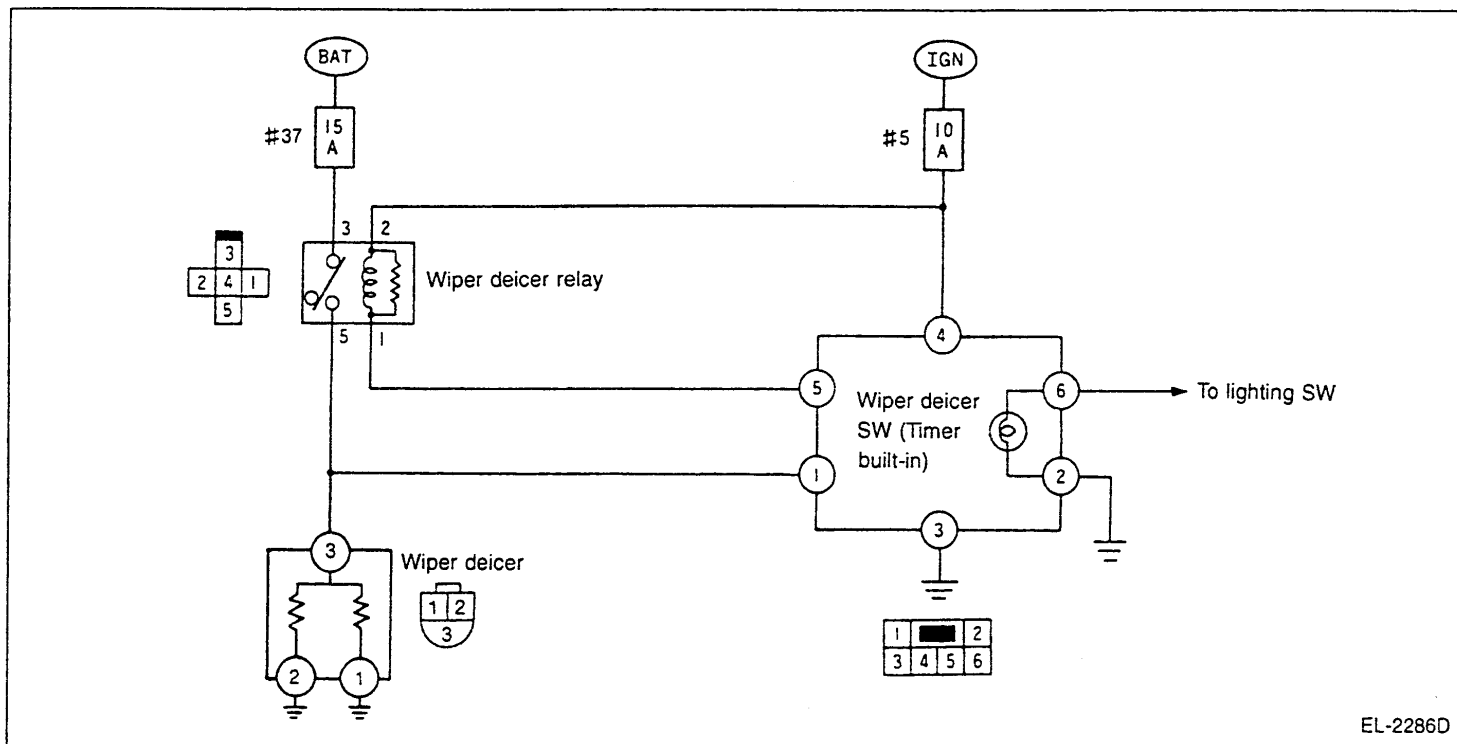

## Wiper Deicer Switch Input/Output Signal Specifications

Terminal No.	Signal name	Measuring condition		Specification	
		Ignition switch	Operation		
1	Indicator power supply	ON	Wiper deicer switch	OFF	Approx. 0V
				ON	Approx. 12V
2	Illumination ground	OFF	—	Approx. 0V	
3	Ground	ON	—	Approx. 0V	
4	Ignition power supply	ON	—	Approx. 12V	
5	Wiper deicer relay control signal	ON	Wiper deicer switch	ON	Approx. 0V*
				OFF	Approx. 12V
6	Illumination power supply	OFF	Lighting switch: 1ST	Approx. 12V	

\*: When the wiper deicer is activated (approx. 15 minutes).



SECTION **SD**

GI  
EC  
AT  
BR  
ST  
RS  
HA  
EL  
**SD**

**CONTENTS**

<input type="text"/> RB20DE (L/B) <input type="text"/>	
ENGINE MECHANICAL .....	2
<input type="text"/> RB25DE <input type="text"/>	
ENGINE MECHANICAL .....	4
<input type="text"/> RB25DET <input type="text"/>	
ENGINE MECHANICAL .....	6
CLUTCH .....	8
<input type="text"/> FS5W71C <input type="text"/>	
MANUAL TRANSMISSION .....	9

<input type="text"/> FS5R30A <input type="text"/>	
MANUAL TRANSMISSION .....	10
AUTOMATIC TRANSMISSION .....	12
TRANSFER .....	18
PROPELLER SHAFT .....	19
FRONT FINAL DRIVE .....	20
REAR FINAL DRIVE .....	22
DRIVE SHAFT .....	24
AXLE & SUSPENSION .....	25
ROAD WHEEL AND TIRE .....	27
BRAKE .....	28
STEERING .....	29
SUPER HICAS .....	30

**STANDARD AND REPAIR LIMIT**

Firing order		1-5-3-6-2-4					
Compression pressure	MPa (kg/cm <sup>2</sup> )/rpm	Standard	1.23 (12.5)/300				
		Limit	0.93 (9.5)/300				
		Limit of variation between cylinders	0.1 (1.0)/300				
Distortion limit	mm	Intake manifold	0.1				
		Intake manifold collector	0.1				
		Exhaust manifold	0.3				
		Cylinder head	0.2				
		Cylinder block	0.1				
Engine oil capacity	ℓ	Without filter	Approx. 3.8				
		With filter	Approx. 4.2				
Spark plug	Maker/Type/Spark plug gap	mm	NGK/PFR5G-11/1.0 - 1.1				
Ignition advance device		Electronically-controlled ignition advance					
Engine idling speed		rpm	650±50 (N or P position for A/T)				
Idle base speed (during no feed back control)		rpm	600 (N or P position for A/T)				
Density of CO/HC at idling speed		%/ppm	Less than 0.1/Less than 50				
Ignition timing (during no feed back control)		BTDC°/rpm	10±2/600				
Valve clearance (INT/EXH)	mm	Hot engine	0.36±0.062/0.53±0.062				
		Cold engine (at ambient temperature)	0.31±0.04/0.50±0.04				
Fuel tank capacity		ℓ	Approx. 65				
Engine coolant total capacity [with reservoir tank (max. level)]		ℓ	Approx. 9.4				
Thermostat opening temperature [start to open - full open]		°C	82 - 95				
Radiator cap opening pressure		MPa (kg/cm <sup>2</sup> )	0.06 - 0.10 (0.6 - 1.0)				
			New	Used	Limit		
Deflection amount of accessory V-belt	Measured with tension gauge	N (kg)	Power steering pump belt		667 - 755 (68 - 77)	559 - 637 (57 - 65)	284 (29)
			A/C compressor belt		667 - 755 (68 - 77)	559 - 637 (57 - 65)	284 (29)
			Fan belt		667 - 755 (68 - 77)	559 - 637 (57 - 65)	284 (29)
Measured by pushing at 98 N (10 kg)	mm	Power steering pump belt		8 - 10	10 - 12	16	
		A/C compressor belt		6 - 8	7 - 9	12	
		Fan belt		3 - 5	4 - 6	7.5	

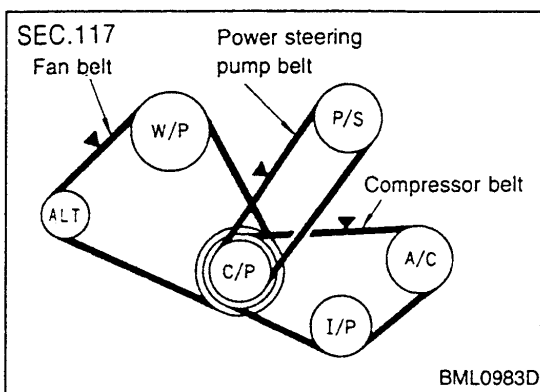

## TIGHTENING TORQUE

Unit: N·m (kg·m)

Engine cover	5.0 - 6.5 (0.51 - 0.66)
* Throttle body	1) 8.8 - 11 (0.9 - 1.1) 2) 18 - 22 (1.8 - 2.2)
Throttle position sensor	2.0 - 2.4 (0.20 - 0.24)
IAA unit (ACC valve)	8.4 - 11 (0.86 - 1.1)
* Intake manifold collector (upper)	18 - 22 (1.8 - 2.2)
* Intake manifold collector	18 - 22 (1.8 - 2.2)
* Intake manifold	18 - 24 (1.8 - 2.4)
Vacuum tank	5.1 - 6.5 (0.52 - 0.66)
Engine coolant temperature sensor	20 - 29 (2.0 - 3.0)
* Fuel tube	1) 9.3 - 11 (0.95 - 1.1) 2) 21 - 26 (2.1 - 2.7)
Pressure regulator	2.9 - 3.8 (0.30 - 0.39)
Fuel damper	2.9 - 3.8 (0.30 - 0.39)
Fuel hose clamp bolt (in engine compartment)	1.0 - 1.5 (0.10 - 0.15)
Exhaust manifold cover	3.9 - 4.9 (0.4 - 0.5)
* Exhaust manifold	27 - 31 (2.8 - 3.2)
Oxygen sensor	40 - 60 (4.1 - 6.1)
Crank pulley	142 - 152 (14.5 - 15.5)
Cam pulley (INT)	108 - 118 (11.0 - 12.0)
Cam pulley (EXH)	14 - 19 (1.4 - 1.9)
Timing belt cover	5.3 - 7.5 (0.54 - 0.76)
Timing belt rear cover	5.3 - 7.5 (0.54 - 0.76)
Tensioner pulley	43 - 58 (4.4 - 5.9)
Idler pulley	43 - 58 (4.4 - 5.9)
Crankshaft position sensor	21 - 26 (2.1 - 2.7)
* Oil pan	6.3 - 8.3 (0.64 - 0.85)
Oil strainer	16 - 21 (1.6 - 2.1)
Oil pan drain plug	29 - 39 (3.0 - 4.0)
Ignition coil	5.1 - 6.5 (0.52 - 0.66)
Spark plug	20 - 29 (2.0 - 3.0)
* Rocker cover	1) 5.5 - 7.5 (0.56 - 0.76) 2) 5.5 - 7.5 (0.56 - 0.76) (Tighten separately in twice.)
* Camshaft bracket	1) 2.0 (0.2) 2) 5.9 (0.6) 3) 9.0 - 12 (0.92 - 1.2)
Camshaft baffle plate	8.1 - 9.2 (0.83 - 0.94)

Unit: N·m (kg·m)

* Cylinder head bolt	1) 29 (3.0) 2) 98 (10.0) 3) 0 (0) 4) 25 - 34 (2.5 - 3.5) 5) 95° - 100° (Angle tightening)
Cylinder head sub bolt	9.0 - 12 (0.92 - 1.2)
VTC solenoid	25 - 34 (2.5 - 3.5)
* Main bearing cap	49 - 59 (5.0 - 6.0)
Connecting rod nut	1) 14 - 16 (1.4 - 1.6) 2) 45° - 50° (Angle tightening)
Flywheel and drive plate	93 - 103 (9.5 - 10.5)
Engine coolant drain plug	34 - 44 (3.5 - 4.5)
Knock sensor	25 - 34 (2.5 - 3.5)
Radiator mounting bracket	3.8 - 4.5 (0.39 - 0.46)
Auxiliary electric fan	5.1 - 6.5 (0.52 - 0.66)
Water pump (M6 bolt)	17 - 21 (1.7 - 2.1)
(M8 bolt)	20 - 23 (2.0 - 2.3)
(M10 bolt)	35 - 47 (3.6 - 4.8)
Water inlet	16 - 21 (1.6 - 2.1)
Oil pump assembly	9.0 - 12 (0.92 - 1.2)
Accelerator cable lock nut	7.8 - 11 (0.8 - 1.1)
Fuel tank strap	26 - 36 (2.7 - 3.7)
Fuel sender unit lock ring	30 - 35 (3.1 - 3.6)
Exhaust manifold to front tube	45 - 60 (4.6 - 6.1)
Front tube to catalytic converter	51 - 65 (5.2 - 6.6)
Catalytic converter to center tube	51 - 65 (5.2 - 6.6)
Center tube to main muffler	30 - 39 (3.1 - 4.0)
Alternator (main)	45 - 60 (4.6 - 6.1)
(stay side)	16 - 21 (1.6 - 2.1)
Starter motor	41 - 52 (4.2 - 5.3)

\*: Tighten as specified tightening order.

1): Tighten separately in several times.

GI

EC

AT

BR

ST

RS

HA

EL

SD

STANDARD AND REPAIR LIMIT

Firing order		1-5-3-6-2-4		
Compression pressure MPa (kg/cm <sup>2</sup> )/rpm	Standard	1.26 (12.8)/300		
	Limit	0.96 (9.8)/300		
	Limit of variation between cylinders	0.1 (1.0)/300		
Distortion limit mm	Intake manifold	0.1		
	Intake manifold collector	0.1		
	Exhaust manifold	0.3		
	Cylinder head	0.2		
	Cylinder block	0.1		
Engine oil capacity ℓ	Without filter	Approx. 3.8		
	With filter	Approx. 4.2		
Spark plug	Maker/Type/Spark plug gap mm	NGK/PFR5G-11/1.0 - 1.1		
Ignition advance device		Electronically-controlled ignition advance		
Engine idling speed	rpm	650±50 (N or P position for A/T)		
Idle base speed (during no feed back control)	rpm	600 (N or P position for A/T)		
Density of CO/HC at idling speed	%/ppm	Less than 0.1/Less than 50		
Ignition timing (during no feed back control)	BTDC°/rpm	15±2/600		
Valve clearance (INT/EXH) mm	Hot engine	0.36±0.062/0.53±0.062		
	Cold engine (at ambient temperature)	0.31±0.04/0.50±0.04		
Fuel tank capacity	ℓ	Approx. 65		
Engine coolant total capacity [with reservoir tank (max. level)]	ℓ	Approx. 9.4		
Thermostat opening temperature [start to open - full open]	°C	82 - 95		
Radiator cap opening pressure	MPa (kg/cm <sup>2</sup> )	0.06 - 0.10 (0.6 - 1.0)		
		New	Used	Limit
Deflection amount of accessory V-belt Measured with tension gauge N (kg)	Power steering pump belt	667 - 755 (68 - 77)	559 - 637 (57 - 65)	284 (29)
	A/C compressor belt	667 - 755 (68 - 77)	559 - 637 (57 - 65)	284 (29)
	Fan belt	667 - 755 (68 - 77)	559 - 637 (57 - 65)	284 (29)
Measured by pushing at 98 N (10 kg) mm	Power steering pump belt	8 - 10	10 - 12	16
	A/C compressor belt	6 - 8	7 - 9	12
	Fan belt	3 - 5	4 - 6	7.5

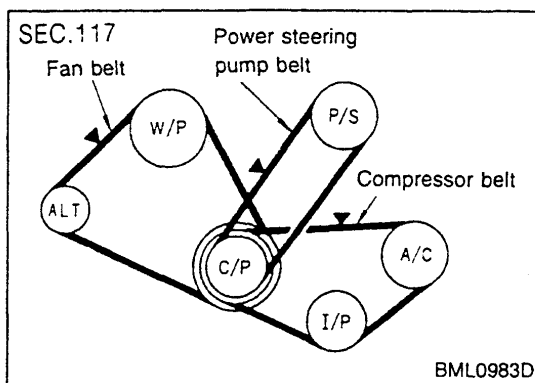

## TIGHTENING TORQUE

Unit: N·m (kg·m)

Engine cover	5.0 - 6.5 (0.51 - 0.66)
* Throttle body	1) 8.8 - 11 (0.9 - 1.1) 2) 18 - 22 (1.8 - 2.2)
Throttle position sensor	2.0 - 2.4 (0.20 - 0.24)
IAA unit (ACC valve)	8.4 - 11 (0.86 - 1.1)
* Intake manifold collector (upper)	18 - 22 (1.8 - 2.2)
* Intake manifold collector	18 - 22 (1.8 - 2.2)
* Intake manifold	18 - 22 (1.8 - 2.2)
Vacuum tank	5.1 - 6.5 (0.52 - 0.66)
Engine coolant temperature sensor	20 - 29 (2.0 - 3.0)
* Fuel tube	1) 9.3 - 11 (0.95 - 1.1) 2) 21 - 26 (2.1 - 2.7)
Pressure regulator	2.9 - 3.8 (0.30 - 0.39)
Fuel damper	2.9 - 3.8 (0.30 - 0.39)
Fuel hose clamp bolt (in engine compartment)	1.0 - 1.5 (0.10 - 0.15)
Exhaust manifold cover	3.9 - 4.9 (0.4 - 0.5)
* Exhaust manifold	27 - 31 (2.8 - 3.2)
Oxygen sensor	40 - 60 (4.1 - 6.1)
Crank pulley	142 - 152 (14.5 - 15.5)
Cam pulley (INT)	108 - 118 (11.0 - 12.0)
Cam pulley (EXH)	14 - 19 (1.4 - 1.9)
Timing belt cover	5.3 - 7.5 (0.54 - 0.76)
Timing belt rear cover	5.3 - 7.5 (0.54 - 0.76)
Tensioner pulley	43 - 58 (4.4 - 5.9)
Idler pulley	43 - 58 (4.4 - 5.9)
Crankshaft position sensor	21 - 26 (2.1 - 2.7)
* Oil pan	6.3 - 8.3 (0.64 - 0.85)
Oil strainer	16 - 21 (1.6 - 2.1)
Oil pan drain plug	29 - 39 (3.0 - 4.0)
Ignition coil	5.1 - 6.5 (0.52 - 0.66)
Spark plug	20 - 29 (2.0 - 3.0)
* Rocker cover	1) 5.5 - 7.5 (0.56 - 0.76) 2) 5.5 - 7.5 (0.56 - 0.76) (Tighten separately in twice.)
* Camshaft bracket	1) 2.0 (0.2) 2) 5.9 (0.6) 3) 9.0 - 12 (0.92 - 1.2)
Camshaft baffle plate	8.1 - 9.2 (0.83 - 0.94)

Unit: N·m (kg·m)

* Cylinder head bolt	1) 29 (3.0) 2) 98 (10.0) 3) 0 (0) 4) 25 - 34 (2.5 - 3.5) 5) 95° - 100° (Angle tightening)
Cylinder head sub bolt	9.0 - 12 (0.92 - 1.2)
VTC solenoid	25 - 34 (2.5 - 3.5)
* Main bearing cap	49 - 59 (5.0 - 6.0)
Connecting rod nut	1) 14 - 16 (1.4 - 1.6) 2) 60° - 65° (Angle tightening)
Flywheel and drive plate	93 - 103 (9.5 - 10.5)
Engine coolant drain plug	34 - 44 (3.5 - 4.5)
Knock sensor	25 - 34 (2.5 - 3.5)
Radiator mounting bracket	3.8 - 4.5 (0.39 - 0.46)
Auxiliary electric fan	5.1 - 6.5 (0.52 - 0.66)
Water pump (M6 bolt)	17 - 21 (1.7 - 2.1)
(M8 bolt)	20 - 23 (2.0 - 2.3)
(M10 bolt)	35 - 47 (3.6 - 4.8)
Water inlet	16 - 21 (1.6 - 2.1)
Oil pump assembly	9.0 - 12 (0.92 - 1.2)
Accelerator cable lock nut	7.8 - 11 (0.8 - 1.1)
Fuel tank strap	26 - 36 (2.7 - 3.7)
Fuel sender unit lock ring	30 - 35 (3.1 - 3.6)
Exhaust manifold to front tube	45 - 60 (4.6 - 6.1)
Front tube to catalytic converter	51 - 65 (5.2 - 6.6)
Catalytic converter to center tube	51 - 65 (5.2 - 6.6)
Center tube to main muffler	30 - 39 (3.1 - 4.0)
Alternator (main)	45 - 60 (4.6 - 6.1)
(stay side)	16 - 21 (1.6 - 2.1)
Starter motor	41 - 52 (4.2 - 5.3)

\*: Tighten as specified tightening order.

1): Tighten separately in several times.

## STANDARD AND REPAIR LIMIT

Firing order		1-5-3-6-2-4				
Compression pressure	MPa (kg/cm <sup>2</sup> )/rpm	Standard	1.20 (12.2)/300			
		Limit	0.90 (9.2)/300			
		Limit of variation between cylinders	0.1 (1.0)/300			
Distortion limit	mm	Intake manifold	0.1			
		Intake manifold collector	0.1			
		Exhaust manifold	0.3			
		Cylinder head	0.2			
		Cylinder block	0.1			
Engine oil capacity	ℓ	Without filter	Approx. 3.9			
		With filter	Approx. 4.3			
Spark plug	Maker/Type/Spark plug gap	mm	NGK/PFR6G-11/1.0 - 1.1			
Ignition advance device		Electronically-controlled ignition advance				
Engine idling speed		rpm	650±50 (N or P position for A/T)			
Idle base speed (during no feed back control)		rpm	600 (N or P position for A/T)			
Density of CO/HC at idling speed		%/ppm	Less than 0.1/Less than 50			
Ignition timing (during no feed back control)		BTDC°/rpm	15±2/600			
Valve clearance (INT/EXH)	mm	Hot engine	0.36±0.062/0.53±0.062			
		Cold engine (at ambient temperature)	0.31±0.04/0.50±0.04			
Fuel tank capacity		ℓ	Approx. 65			
Engine coolant total capacity [with reservoir tank (max. level)]		ℓ	Approx. 9.4			
Thermostat opening temperature [start to open - full open]		°C	82 - 95			
Radiator cap opening pressure		MPa (kg/cm <sup>2</sup> )	0.06 - 0.10 (0.6 - 1.0)			
			New	Used	Limit	
Deflection amount of accessory V-belt	Measured with tension gauge	N (kg)	Power steering pump belt	667 - 755 (68 - 77)	559 - 637 (57 - 65)	284 (29)
			A/C compressor belt	667 - 755 (68 - 77)	559 - 637 (57 - 65)	284 (29)
			Fan belt	667 - 755 (68 - 77)	559 - 637 (57 - 65)	284 (29)
Measured by pushing at 98 N (10 kg)	mm	Power steering pump belt	8 - 10	10 - 12	16	
		A/C compressor belt	6 - 8	7 - 9	12	
		Fan belt	3 - 5	4 - 6	7.5	

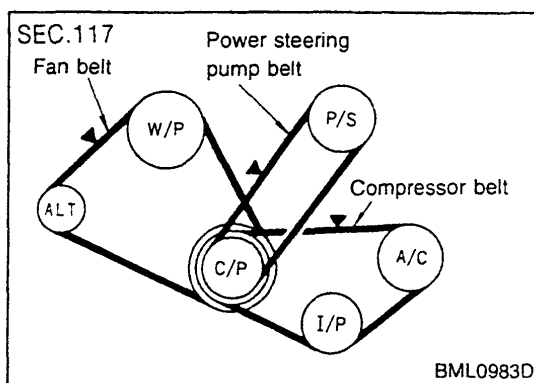

## TIGHTENING TORQUE

Unit: N·m (kg·m)	
Engine cover	5.0 - 6.5 (0.51 - 0.66)
* Throttle body	1) 8.8 - 11 (0.9 - 1.1) 2) 18 - 22 (1.8 - 2.2)
Throttle position sensor	2.0 - 2.4 (0.20 - 0.24)
IAA unit (ACC valve)	8.4 - 11 (0.86 - 1.1)
* Intake manifold collector	18 - 22 (1.8 - 2.2)
* Intake manifold	18 - 22 (1.8 - 2.2)
Engine coolant temperature sensor	20 - 29 (2.0 - 3.0)
* Fuel tube	1) 9.3 - 11 (0.95 - 1.1) 2) 21 - 26 (2.1 - 2.7)
Pressure regulator	2.9 - 3.8 (0.30 - 0.39)
Fuel damper	2.9 - 3.8 (0.30 - 0.39)
Fuel hose clamp bolt (in engine compartment)	1.0 - 1.5 (0.10 - 0.15)
Turbocharger	25 - 39 (2.5 - 4.0)
Oil tube	15 - 20 (1.5 - 2.0)
Water tube (block side)	20 - 31 (2.0 - 3.2)
(turbocharger side)	33 - 41 (3.4 - 4.2)
Oxygen sensor	40 - 60 (4.1 - 6.1)
Exhaust manifold cover	3.9 - 4.9 (0.4 - 0.5)
* Exhaust manifold	27 - 31 (2.8 - 3.2)
Crank pulley	142 - 152 (14.5 - 15.5)
Cam pulley (INT)	108 - 118 (11.0 - 12.0)
Cam pulley (EXH)	14 - 19 (1.4 - 1.9)
Timing belt cover	5.3 - 7.5 (0.54 - 0.76)
Timing belt rear cover	5.3 - 7.5 (0.54 - 0.76)
Tensioner pulley	43 - 58 (4.4 - 5.9)
Idler pulley	43 - 58 (4.4 - 5.9)
Crankshaft position sensor	21 - 26 (2.1 - 2.7)
* Oil pan	6.3 - 8.3 (0.64 - 0.85)
Oil strainer	16 - 21 (1.6 - 2.1)
Oil pan drain plug	29 - 39 (3.0 - 4.0)
Ignition coil	5.1 - 6.5 (0.52 - 0.66)
Spark plug	20 - 29 (2.0 - 3.0)
* Rocker cover	1) 5.5 - 7.5 (0.56 - 0.76) 2) 5.5 - 7.5 (0.56 - 0.76) (Tighten separately in twice.)
* Camshaft bracket	1) 2.0 (0.2) 2) 5.9 (0.6) 3) 9.0 - 12 (0.92 - 1.2)
Camshaft baffle plate	8.1 - 9.2 (0.83 - 0.94)

Unit: N·m (kg·m)	
* Cylinder head bolt	1) 29 (3.0) 2) 98 (10.0) 3) 0 (0) 4) 25 - 34 (2.5 - 3.5) 5) 95° - 100° (Angle tightening)
Cylinder head sub bolt	9.0 - 12 (0.92 - 1.2)
VTC solenoid	25 - 34 (2.5 - 3.5)
* Main bearing cap	49 - 59 (5.0 - 6.0)
Connecting rod nut	1) 14 - 16 (1.4 - 1.6) 2) 60° - 65° (Angle tightening)
Oil jet	30 - 40 (3.1 - 4.1)
Flywheel and drive plate	93 - 103 (9.5 - 10.5)
Engine coolant drain plug	34 - 44 (3.5 - 4.5)
Knock sensor	25 - 34 (2.5 - 3.5)
Radiator mounting bracket	3.8 - 4.5 (0.39 - 0.46)
Auxiliary electric fan	5.1 - 6.5 (0.52 - 0.66)
Water pump (M6 bolt)	17 - 21 (1.7 - 2.1)
(M8 bolt)	20 - 23 (2.0 - 2.3)
(M10 bolt)	35 - 47 (3.6 - 4.8)
Water inlet	16 - 21 (1.6 - 2.1)
Oil pump assembly	9.0 - 12 (0.92 - 1.2)
Accelerator cable lock nut	7.8 - 11 (0.8 - 1.1)
Fuel tank strap	26 - 36 (2.7 - 3.7)
Fuel sender unit lock ring	30 - 35 (3.1 - 3.6)
Exhaust manifold to front tube	45 - 60 (4.6 - 6.1)
Front tube to catalytic converter	51 - 65 (5.2 - 6.6)
Catalytic converter to center tube	51 - 65 (5.2 - 6.6)
Center tube to main muffler	30 - 39 (3.1 - 4.0)
Alternator (main)	45 - 60 (4.6 - 6.1)
(stay side)	16 - 21 (1.6 - 2.1)
Starter motor	41 - 52 (4.2 - 5.3)

\*: Tighten as specified tightening order.

1): Tighten separately in several times.

GI

EC

AT

BR

ST

RS

HA

EL

SD

# CLUTCH

## CLUTCH PEDAL

Engine type		RB20DE	RB25DE	RB25DET
Pedal height	mm	172 - 182		
Pedal height at clutch released	mm	More than 82	More than 81	More than 85
Pedal free play (clevis pin clearance)	mm	9 - 16 (1.0 - 3.0)		

## CLUTCH DISC

Engine type		RB20DE	RB25DE	RB25DET
Size	mm	225 dia.	240 dia.	250 dia.
Wear limit (depth to rivet head)	mm	0.3		
Runout limit / diameter at measurement	mm	Less than 0.7 / 215 dia.	Less than 1.0 / 230 dia.	Less than 0.7 / 240 dia.
Maximum backlash at spline	mm	0.9	1.0	

## CLUTCH COVER

Engine type		RB20DE	RB25DE	RB25DET
Size	mm	225 dia.	240 dia.	250 dia.
Diaphragm spring lever height	mm	33.0 - 35.0	37.5 - 39.5	48.2 - 50.2
Variation in diaphragm spring lever height	mm	Less than 0.7	Less than 0.5	Less than 0.6

## TIGHTENING TORQUE

Unit: N·m (kg·m)

Clutch cover fixing bolt	RB20DE	22 - 29 (2.2 - 3.0)
	RB25DE, RB25DET	35 - 44 (3.5 - 4.5)
Clutch master cylinder fixing bolt		7.9 - 10 (0.8 - 1.1)



**BACKLASH**

Items	Standard mm
Main drive gear	0.05 - 0.10
1st gear	0.05 - 0.20
2nd gear	0.05 - 0.20
3rd gear	0.05 - 0.20
4th gear	—
5th gear	0.05 - 0.20
Reverse idler gear	0.05 - 0.20

**END PLAY**

Items	Standard mm
1st gear	0.31 - 0.41
2nd gear	0.11 - 0.21
3rd gear	0.11 - 0.21
4th gear	—
5th gear	0.24 - 0.41
Reverse idler gear	0.05 - 0.50
Counter gear	0 - 0.16
Main drive gear end play	0 - 0.13
Mainshaft high-synchro side	0 - 0.18
Rear end of mainshaft end bearing	0 - 0.14

**SNAP RING**

Selective parts	Thickness mm	Parts number
Main drive gear	1.87	32204 78001
	1.94	32204 78002
	2.01	32204 78003
Counter drive gear	1.4	32215 E9000
	1.5	32215 E9001
	1.6	32215 E9002
High-synchro side	2.4	32263 V5200
	2.5	32263 V5201
Mainshaft	1.1	32228 20100
	1.2	32228 20101
	1.3	32228 20102
	1.4	32228 20103

**ADJUSTING SHIMS**

Selective parts	Measurement height mm	Thickness mm	Parts number
Counter shaft front bearing	4.52 - 4.71	—	—
	4.42 - 4.51	0.1	32218 V5000
	4.32 - 4.41	0.2	32218 V5001
	4.22 - 4.31	0.3	32218 V5002
	4.12 - 4.21	0.4	32218 V5003
	4.02 - 4.11	0.5	32218 V5004
	3.92 - 4.01	0.6	32218 V5005

**BALK RING CLEARANCE**

Measurement position	Standard mm	Wear limit mm	
1st	1.20 - 1.60	Less than 0.8	
2nd and 3rd	Inner baulk ring clearance "a"	0.70 - 0.90	Less than 0.2
	Outer baulk ring clearance "b"	0.60 - 1.10	Less than 0.2
<p style="text-align: center;">MTA0004D</p>			
4th and 5th	1.20 - 1.60	Less than 0.8	
Reverse gear	1.10 - 1.55	Less than 0.7	

**TIGHTENING TORQUE**

Unit: N·m (kg·m)

Transmission to engine mounting bolt	T/M side to engine side	40 - 49 (4.0 - 5.0)
	Engine side to T/M side	30 - 39 (3.0 - 4.0)

GI  
EC  
AT  
BR  
ST  
RS  
HA  
EL  
SD

**END PLAY**

Items	Standard mm
1st gear	0.23 - 0.33
2nd gear	0.23 - 0.33
3rd gear	0.06 - 0.16
4th gear	—
5th gear	0.23 - 0.33
Reverse gear	0.33 - 0.43
Reverse idler gear	0.30 - 0.53
Counter gear	0.10 - 0.25
Main drive gear end play	0 - 0.10
Mainshaft (front) end play	0 - 0.10
Mainshaft (rear) end play	0 - 0.10
Counter gear (front) end play	0.10 - 0.25
Counter gear (rear) end play	0 - 0.10

**SNAP RING AND C-RING**

Selective parts	Thickness mm	Parts number
Main drive gear	1.89	32204 01G60
	1.95	32204 01G61
	1.99	32204 01G62
	2.03	32204 01G63
	2.07	32204 01G64
	2.11	32204 01G65
Mainshaft (front)	1.99	32204 01G62
	2.03	32204 01G63
	2.07	32204 01G64
	2.11	32204 01G65
	2.15	32204 01G66
	2.19	32204 01G67
Mainshaft (rear)	2.63	32348 01G15
	2.70	32348 01G00
	2.77	32348 01G01
	2.84	32348 01G02
	2.91	32348 01G03
	2.98	32348 01G04
	3.05	32348 01G05
	3.12	32348 01G06
	3.19	32348 01G07
	3.26	32348 01G08
	3.33	32348 01G09
	3.40	32348 01G10
	3.47	32348 01G11
	3.54	32348 01G12
3.61	32348 01G13	
3.68	32348 01G14	
Counter gear (rear)	1.32	32236 01G00
	1.38	32236 01G01
	1.44	32236 01G02
	1.50	32236 01G03
	1.56	32236 01G04
	1.62	32236 01G05
	1.68	32236 01G06
1.74	32236 01G07	

**THRUST WASHER**

Selective parts	Thickness mm	Parts number
Counter gear (front)	0.80	32218 01G00
	0.88	32218 01G11
	0.96	32218 01G12
	1.04	32218 01G13
	1.12	32218 01G14
	1.20	32218 01G04
	1.28	32218 01G15
	1.36	32218 01G16
Reverse idler	1.44	32218 01G17
	1.97	32284 01G10
	2.07	32284 01G11

**BAULK RING CLEARANCE**

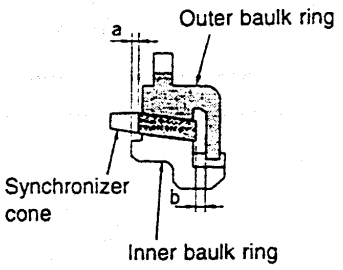
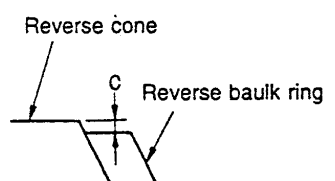
Measurement position	Standard mm	Wear limit mm
1st, 2nd and 3rd (double cone)		
Inner baulk ring clearance "a"	0.70 - 0.90	Less than 0.2
Outer baulk ring clearance "b"	0.60 - 1.10	Less than 0.2
 <p>Outer baulk ring</p> <p>Synchronizer cone</p> <p>Inner baulk ring</p> <p>MTA0004D</p>		
4th and 5th	1.05 - 1.30	Less than 0.7
Reverse gear		
Reverse baulk ring clearance "c"	-0.10 to 0.35	Less than 0.7
 <p>Reverse cone</p> <p>Reverse baulk ring</p> <p>MTA0046D</p>		

GI  
EC  
AT  
BR  
ST  
RS  
HA  
EL

SD

**TIGHTENING TORQUE**

Unit: N·m (kg·m)

Transmission to engine mounting bolt	T/M side to engine side	40 - 49 (4.0 - 5.0)
	Engine side to T/M side	30 - 39 (3.0 - 4.0)

# AUTOMATIC TRANSMISSION

## SHIFT SPEED

Engine type (model code)		RB20DE (4AX03)					
Throttle position	Shift pattern	Vehicle speed km/h					
		D <sub>1</sub> →D <sub>2</sub>	D <sub>2</sub> →D <sub>3</sub>	D <sub>3</sub> →D <sub>4</sub>	D <sub>4</sub> →D <sub>3</sub>	D <sub>3</sub> →D <sub>2</sub>	D <sub>2</sub> →D <sub>1</sub>
Full throttle	Normal	46 - 50	91 - 99	149 - 159	144 - 154	86 - 94	41 - 45
	Power	46 - 50	91 - 99	149 - 159	144 - 154	86 - 94	41 - 45
Half throttle	Normal	31 - 35	62 - 68	101 - 109	71 - 79	41 - 45	6 - 10
	Power	43 - 47	84 - 90	135 - 143	83 - 91	45 - 51	6 - 10

Engine type (model code)		RB25DE (4AX01)					
Throttle position	Shift pattern	Vehicle speed km/h					
		D <sub>1</sub> →D <sub>2</sub>	D <sub>2</sub> →D <sub>3</sub>	D <sub>3</sub> →D <sub>4</sub>	D <sub>4</sub> →D <sub>3</sub>	D <sub>3</sub> →D <sub>2</sub>	D <sub>2</sub> →D <sub>1</sub>
Full throttle	Normal	50 - 54	101 - 109	157 - 167	151 - 161	96 - 104	40 - 44
	Power	50 - 54	101 - 109	157 - 167	151 - 161	96 - 104	40 - 44
Half throttle	Normal	32 - 36	61 - 67	104 - 112	80 - 88	37 - 43	6 - 10
	Power	42 - 46	85 - 91	135 - 143	87 - 95	45 - 51	6 - 10

Engine type (model code)		RB25DET (4AX00)					
Throttle position	Shift pattern	Vehicle speed km/h					
		D <sub>1</sub> →D <sub>2</sub>	D <sub>2</sub> →D <sub>3</sub>	D <sub>3</sub> →D <sub>4</sub>	D <sub>4</sub> →D <sub>3</sub>	D <sub>3</sub> →D <sub>2</sub>	D <sub>2</sub> →D <sub>1</sub>
Full throttle	Normal	45 - 49	103 - 111	167 - 177	161 - 171	98 - 106	40 - 44
	Power	45 - 49	103 - 111	167 - 177	161 - 171	98 - 106	40 - 44
Half throttle	Normal	31 - 35	74 - 80	111 - 119	63 - 71	32 - 38	6 - 10
	Power	39 - 43	84 - 90	133 - 141	98 - 106	50 - 56	6 - 10

# AUTOMATIC TRANSMISSION

## LOCK-UP SPEED

Engine type (model code)		RB20DE (4AX03)	RB25DE (4AX01)	RB25DET (4AX00)	
Vehicle speed in D <sub>3</sub> position	Lock-up ON	Closed throttle	31 - 39	34 - 42	—
		Half throttle	—	—	—
	Lock-up OFF	Closed throttle	23 - 31	25 - 33	59 - 67
		Half throttle	101 - 109	104 - 112	121 - 129
Vehicle speed in D <sub>4</sub> position	Lock-up ON	Closed throttle	44 - 52	48 - 56	55 - 63
		Half throttle	120 - 128	118 - 126	128 - 136
	Lock-up OFF	Closed throttle	35 - 43	38 - 46	52 - 60
		Half throttle	110 - 118	107 - 115	103 - 111

Closed throttle: Throttle opening of less than 1/8 with the closed throttle position switch off position

Half throttle: Throttle opening of 4/8

## STALL SPEED

Engine type (model code)	Stall engine speed rpm
RB20DE (4AX03)	2,300 - 2,500
RB25DE (4AX01)	2,350 - 2,550
RB25DET (4AX00)	2,920 - 3,170

## LINE PRESSURE

Engine speed	Line pressure MPa (kg/cm <sup>2</sup> )	
	R position	D, 2, and 1 positions (4AT) D, 3, and 2 positions (M-AT)
At idle engine speed	0.58 - 0.62 (5.9 - 6.3)	0.47 - 0.51 (4.8 - 5.2)
At stall engine speed	1.71 - 1.78 (17.4 - 18.2)	1.22 - 1.29 (12.4 - 13.2)

GI  
EC  
AT  
BR  
ST  
RS  
HA  
EL

SD

# AUTOMATIC TRANSMISSION

## CONTROL VALVE SPECIFICATIONS

Valve location	Valve designation		Total length mm	Parts number	
Upper body	L1	Torque converter regulator valve	27.5	31780 41X01	
	L2	Pressure modifier valve	43.5	31751 41X02	
	L3	Pressure regulator valve	68.0	31741 80X00	
	L4	Accumulator control valve	4AX03 model	55.5	31772 4AX00
			Except 4AX03 model		31772 4AX02
		Throttle accumulator piston		19.5	31675 41X07
	L5	Shift valve B		56.0	31766 4AX00
	L6	Shift valve A		75.0	31766 51X03
	L7	Overrun clutch control valve	4AX03 model	63.5	31766 51X04
			Except 4AX03 model	65.0	31766 4AX02
L8	Overrun clutch reducing valve		54.5	31772 41X06	
L9	Pilot valve		38.5	31772 41X01	
L10	Torque converter clutch control valve		58.0	31832 4AX01	
Lower body	L11	Shuttle shift valve S	4AX03 model	57.0	31766 51X05
			Except 4AX03 model	67.0	31766 4AX01
	L13	1 reducing valve		37.5	31772 41X12
	L14	3-2 timing valve	4AX03 model	37.5	31772 4AX01
			Except 4AX03 model	41.0	31772 71X00
	L15	Servo charger valve		66.0	31772 41X03
L16	Lock-up regulator valve		38.5	31772 21X00	

## CONTROL VALVE SPRING SPECIFICATIONS

Unit: mm

Valve spring location	Valve spring designation		Free length "ℓ"	Outer diameter "D"	Wire diameter "d"	Winding direction	Parts number	
Upper body	L1	Torque converter regulator valve spring		36.0	9.0	1.4	Right	31742 4AX00
	L2	Pressure modifier valve spring		31.95	6.8	0.8	↑	31742 41X19
	L3	Pressure regulator valve spring		31.8	15.0	1.3	↑	31742 4AX01
	L4	Throttle accumulator piston spring A		30.5	9.8	1.3	↑	31742 41X15
	L5	Shift valve B spring		23.5	11.0	0.8	↑	31742 4AX02
	L6	Shift valve A spring		25.0	7.0	0.65	↑	31762 41X01
	L7	Overrun clutch control valve spring	4AX03 model	23.6	7.0	0.6	↑	31762 41X03
			Except 4AX03 model	38.3	8.0	0.55	↑	31762 4AX00
	L8	Overrun clutch reducing valve spring	4AX03 model	32.5	7.0	0.85	↑	31742 41X63
			Except 4AX03 model	35.5	7.0	0.9	↑	31742 41X65
L9	Pilot valve spring		26.5	9.0	1.1	↑	31742 4AX03	
L10	Torque converter clutch control valve spring		46.5	6.5	0.8	↑	31742 4AX04	
Lower body	L11	Shuttle shift valve S spring	4AX03 model	54.0	5.65	0.75	↑	31762 4AX01
			Except 4AX03 model	25.0	7.0	0.65	↑	31762 41X01
	L13	1 reducing valve spring	4AX00 model	22.6	6.7	0.7	↑	31742 4AX06
			Except 4AX00 model	25.4	6.75	0.75	↑	31756 41X05
	L14	3-2 timing valve spring		23.0	6.7	0.7	↑	31742 41X06
	L15	Servo charger valve spring		23.0	6.7	0.7	↑	31742 41X06
L16	Lock-up regulator valve spring		33.89	6.95	0.55	↑	31742 4AX05	

# AUTOMATIC TRANSMISSION

## ACCUMULATOR

### Accumulator spring

Spring designation		Free length mm	Parts number
Accumulator spring A		43.0	31605 41X02
Accumulator spring B	4AX03 model	66.0	31605 41X10
	Except 4AX03 model		31605 4AX03
Accumulator spring C		45.0	31605 4AX00
Accumulator spring D		58.4	31605 41X06

### Accumulator O-ring

Accumulator		A	B	C	D
Large O-ring	mm	45	50	50	45
Small O-ring	mm	29	45	34	29

## BAND SERVO PISTON

### Band servo piston spring

Model code	4AX00, 4AX01		4AX03	
	Spring designation	Free length mm	Parts number	Free length mm
Band servo piston spring A	47.6	31605 41X14	47.6	31605 41X18
Band servo piston spring B	—	—	—	—
Band servo piston spring C	29.7	31605 41X01	29.7	31605 41X01

## CLUTCH AND BRAKE

Designation		Reverse clutch				High clutch			
Model code		4AX00		4AX01, 4AX03		4AX00		4AX01	
Drive plate	Number of plates	2		2		7		5	
	Parts number	31532 41X73		31532 41X24		31532 41X04		31532 41X11	
	Thickness mm	2.0		2.0		1.6		1.6	
	Wear limit mm	1.8		1.8		1.4		1.4	
Driven plate	Number of plates	2		2		7		5	
	Parts number	31536 41X20		31536 41X14		31536 41X19		31536 41X19	
	Thickness mm	2.8		2.0		2.0		2.0	
Clearance	mm	0.5 - 0.8		0.5 - 0.8		1.8 - 2.2		1.8 - 2.2	
Retaining plate	Thickness mm	Parts number	Thickness mm	Parts number	Thickness mm	Parts number	Thickness mm	Parts number	
	4.6	31537 42X20	4.8	31537 42X02	3.6	31537 41X61	3.4	31537 41X71	
	4.8	31537 42X21	5.0	31537 42X03	3.8	31537 41X62	3.6	31537 41X61	
	5.0	31537 42X22	5.2	31537 42X04	4.0	31537 41X63	3.8	31537 41X62	
	5.2	31537 42X23	5.4	31537 42X05	4.2	31537 41X64	4.0	31537 41X63	
	5.4	31537 42X24	5.6	31537 42X06	4.4	31537 41X65	4.2	31537 41X64	
					4.6	31537 41X66	4.4	31537 41X65	
					4.8	31537 41X67	4.6	31537 41X66	
					5.0	31537 41X68	4.8	31537 41X67	

# AUTOMATIC TRANSMISSION

Designation		High clutch		Forward clutch			
Model code		4AX03		4AX00		4AX01, 4AX03	
Drive plate	Number of plates	4		7		6	
	Parts number	31532 41X11		31532 41X63		31532 41X63	
	Thickness mm	1.6		2.0		2.0	
	Wear limit mm	1.4		1.8		1.8	
Driven plate	Number of plates	7		7		6	
	Parts number	31536 41X21		31536 41X13		31536 41X13	
	Thickness mm	2.0		2.0		2.0	
Clearance mm	1.8 - 2.2		0.35 - 0.75		0.35 - 0.75		
Retaining plate	Thickness mm	Parts number	Thickness mm	Parts number	Thickness mm	Parts number	
	3.4	31537 41X71	2.4	31537 4AX12	5.2	31537 4AX00	
	3.6	31537 41X61	5.2	31537 4AX00	5.4	31537 4AX01	
	3.8	31537 41X62	5.4	31537 4AX01	5.6	31537 4AX02	
	4.0	31537 41X63	5.6	31537 4AX02	5.8	31537 4AX03	
	4.2	31537 41X64	5.8	31537 4AX03	6.0	31537 4AX04	
			6.0	31537 4AX04	6.2	31537 4AX05	
		6.2	31537 4AX05	6.4	31537 4AX06		
		6.4	31537 4AX06				

Designation		Overrun clutch		Low & reverse brake			
Model code		4AX00, 4AX01, 4AX03		4AX00		4AX01, 4AX03	
Drive plate	Number of plates	3		7		5	
	Parts number	31532 41X62		31532 41X69		31532 41X69	
	Thickness mm	2.0		1.6		1.6	
	Wear limit mm	1.8		1.4		1.4	
Driven plate	Number of plates	5		7		7	
	Parts number	31536 41X10		31666 41X02		31666 41X02	
	Thickness mm	2.0		2.0		2.0	
Clearance mm	1.0 - 1.4		0.5 - 0.8		0.5 - 0.8		
Retaining plate	Thickness mm	Parts number	Thickness mm	Parts number	Thickness mm	Parts number	
	4.2	31537 43X00	6.6	31667 41X17	7.2	31667 41X13	
	4.4	31537 43X01	6.8	31667 41X11	7.4	31667 41X14	
	4.6	31537 43X02	7.0	31667 41X12	7.6	31667 41X07	
	4.8	31537 43X03	7.2	31667 41X13	7.8	31667 41X08	
	5.0	31537 43X04	7.4	31667 41X14	8.0	31667 41X00	
			7.6	31667 41X07	8.2	31667 41X01	
			7.8	31667 41X08	8.4	31667 41X02	
			8.0	31667 41X00	8.6	31667 41X03	
			8.2	31667 41X01	8.8	31667 41X04	
			8.4	31667 41X02	9.0	31667 41X05	
			8.6	31667 41X03	9.2	31667 41X06	
			8.8	31667 41X04			
		9.0	31667 41X05				



# AUTOMATIC TRANSMISSION

## OIL PUMP AND LOW ONE-WAY CLUTCH

Oil pump clearance	mm	Outer gear to cresendo	0.15 - 0.22
		Outer gear to housing	0.11 - 0.18
		Inner gear and outer gear to housing	0.03 - 0.05
Oil pump cover to seal ring clearance	mm	Standard	0.10 - 0.25
		Limit	0.25
Low one-way clutch inner race to seal ring clearance	mm	Standard	0.10 - 0.25
		Limit	0.25

## TOTAL END PLAY

Total end play	mm	0.25 - 0.55	
Bearing race		Thickness mm	Parts number
		0.8	31435 41X01
		1.0	31435 41X02
		1.2	31435 41X03
		1.4	31435 41X04
		1.6	31435 41X05
		1.8	31435 41X06
		2.0	31435 41X07

## REVERSE CLUTCH END PLAY

Reverse clutch drum end play	mm	0.55 - 0.90	
Oil pump thrust washer		Thickness mm	Parts number
		0.9	31528 21X01
		1.1	31528 21X02
		1.3	31528 21X03
		1.5	31528 21X04
		1.7	31528 21X05
		1.9	31528 21X06

## ADJUSTMENT OF TANDEM BRAKE BAND TENSION

Anchor end pin tightening torque	N·m (kg·m)	4.0 - 5.8 (0.4 - 0.6)
Number of turns of anchor end pin back-off		2.375 - 2.625
Lock nut tightening torque	N·m (kg·m)	41 - 50 (4.1 - 5.2)

## TIGHTENING TORQUE

Unit: N·m (kg·m)

Transmission to engine mounting bolt	T/M side to engine side	40 - 49 (4.0 - 5.0)
	Engine side to T/M side	30 - 39 (3.0 - 4.0)

# TRANSFER

## END PLAY

Designation	Standard mm
Clutch hub	0.2 - 0.35
Multiple disc clutch	0.2 - 0.5

## CLUTCH HUB BEARING ADJUSTING SHIM

Thickness mm	Parts number	Thickness mm	Parts number
0.40	33112 05U04	0.80	33112 05U02
0.50	33112 05U05	0.90	33112 05U03
0.60	33112 05U00	1.00	33112 05U06
0.70	33112 05U01		

## RETAINER PLATE

Thickness mm	Parts number	Thickness mm	Parts number
4.8	31537 1P400	6.0	31537 1P406
5.0	31537 1P401	6.2	31537 1P407
5.2	31537 1P402	6.4	31537 1P408
5.4	31537 1P403	6.6	31537 1P409
5.6	31537 1P404	6.8	31537 1P410
5.8	31537 1P405	7.0	31537 1P411

## CLUTCH SPECIFICATIONS

Drive plate	Number of plates	7
	Parts number	31532 05U00
	Thickness mm	2.0
	Wear limit mm	1.8
Driven plate	Number of plates	12
	Parts number	31536 1P400
	Thickness mm	2.0

# PROPELLER SHAFT

## RUNOUT

Type	Journal bearing end play mm	Amount of runout mm
2S56A 3S63C-T 3S71C-T 3F80A-2VL107	0	Less than 0.6

## TIGHTENING TORQUE

Unit: N·m (kg·m)

Center bearing bracket to underbody	42 - 48 (4.2 - 4.9)
Propeller shaft flange yoke to companion flange	55 - 64 (5.6 - 6.6)

GI

EC

AT

FA

BR

RS

HA

EL

**SD**

# FRONT FINAL DRIVE

## DRIVE GEAR RUNOUT

Type	Amount of runout at reverse side of drive gear mm
F160	Less than 0.05

## ADJUSTMENT OF SIDE GEAR CLEARANCE

Type	Clearance at reverse side of side gear mm
F160	Less than 0.15, and side gear must be rotated freely.

## Thrust washer for adjustment of clearance at reverse side of side gear

Thickness mm	Parts number	Thickness mm	Parts number	Thickness mm	Parts number	Thickness mm	Parts number
0.68	38424 W1010	0.77	38424 W1013	0.86	38424 W1016	0.95	38424 W1019
0.71	38424 W1011	0.80	38424 W1014	0.89	38424 W1017	0.98	38424 W1020
0.74	38424 W1012	0.83	38424 W1015	0.92	38424 W1018	1.01	38424 W1021

## ADJUSTMENT OF DRIVE PINION HEIGHT

### Adjusting washer for adjustment of drive pinion height

Thickness mm	Parts number	Thickness mm	Parts number	Thickness mm	Parts number	Thickness mm	Parts number
3.09	38154 U1500	3.24	38154 U1505	3.39	38154 U1510	3.54	38154 U1515
3.12	38154 U1501	3.27	38154 U1506	3.42	38154 U1511	3.57	38154 U1516
3.15	38154 U1502	3.30	38154 U1507	3.45	38154 U1512	3.60	38154 U1517
3.18	38154 U1503	3.33	38154 U1508	3.48	38154 U1513	3.63	38154 U1518
3.21	38154 U1504	3.36	38154 U1509	3.51	38154 U1514	3.66	38154 U1519

## ADJUSTMENT OF DRIVE PINION PRE-LOAD

Type	Drive pinion pre-load N·m (kg·m)
F160	0.8 - 1.0 (0.08 - 0.11)

### Adjusting washer for adjustment of drive pinion pre-load

Thickness mm	Parts number	Thickness mm	Parts number	Thickness mm	Parts number	Thickness mm	Parts number
2.31	38141 09400	2.39	38137 09400	2.47	38133 09400	2.55	38129 09400
2.33	38140 09400	2.41	38136 09400	2.49	38132 09400	2.57	38128 09400
2.35	38139 09400	2.43	38135 09400	2.51	38131 09400	2.59	38127 09400
2.37	38138 09400	2.45	38134 09400	2.53	38130 09400		

### Adjusting spacer for adjustment of drive pinion pre-load

Thickness mm	Parts number	Thickness mm	Parts number	Thickness mm	Parts number
56.2	38130 21000	56.6	38132 21000	57.0	38134 21000
56.4	38131 21000	56.8	38133 21000	57.2	38135 21000

# FRONT FINAL DRIVE

## ADJUSTMENT OF SIDE BEARING PRE-LOAD

Adjusting washer for adjustment of side bearing pre-load

Side retainer side

Thickness mm	Parts number	Thickness mm	Parts number	Thickness mm	Parts number	Thickness mm	Parts number
0.35	38453 03V60	0.60	38453 03V65	0.85	38453 03V70	1.10	38453 03V75
0.40	38453 03V61	0.65	38453 03V66	0.90	38453 03V71	1.15	38453 03V76
0.45	38453 03V62	0.70	38453 03V67	0.95	38453 03V72		
0.50	38453 03V63	0.75	38453 03V68	1.00	38453 03V73		
0.55	38453 03V64	0.80	38453 03V69	1.05	38453 03V74		

Carrier case side

Thickness mm	Parts number	Thickness mm	Parts number	Thickness mm	Parts number	Thickness mm	Parts number
1.95	38453 03V00	2.15	38453 03V04	2.35	38453 03V08	2.55	38453 03V12
2.00	38453 03V01	2.20	38453 03V05	2.40	38453 03V09	2.60	38453 03V13
2.05	38453 03V02	2.25	38453 03V06	2.45	38453 03V10	2.65	38453 03V14
2.10	38453 03V03	2.30	38453 03V07	2.50	38453 03V11		

## ADJUSTMENT OF TOTAL PRE-LOAD

Type	F160		
Total pre-load with oil seal installed	N·m (kg·m)	1.6 - 2.1 (0.16 - 0.22)	
Drive gear backlash	mm	0.10 - 0.15	

## ADJUSTMENT OF SIDE SHAFT END PLAY

Type	F160		
Side shaft end play	mm	0 - 0.1	

Adjusting shim for adjustment of side shaft end play

Thickness mm	Parts number	Thickness mm	Parts number
0.1	38233 03V01	0.4	38233 03V04
0.2	38233 03V02	0.5	38233 03V05
0.3	38233 03V03		

# REAR FINAL DRIVE

## DRIVE GEAR RUNOUT

Type	Amount of runout at reverse side of drive gear mm
R200 (Strengthened), R200V (Strengthened)	Less than 0.05

## ADJUSTMENT OF SIDE GEAR CLEARANCE

Type	Clearance at reverse side of side gear mm
R200 (Strengthened)	Less than 0.15, and side gear must be rotated freely.
R200V (Strengthened)	0.03 - 0.09

## Thrust washer for adjustment of clearance at reverse side of side gear

Type	R200 (Strengthened, 2-pinion)		R200 (Strengthened, 4-pinion)		R200V (Strengthened)	
	Thickness mm	Parts number	Thickness mm	Parts number	Thickness mm	Parts number
Thrust washer	0.75 - 0.78	38424 N3110	0.75 - 0.80	38424 10V00	0.80	38424 40F60
	0.78 - 0.81	38424 N3111	0.80 - 0.85	38424 10V01	0.83	38424 40F61
	0.81 - 0.84	38424 N3112	0.85 - 0.90	38424 10V02	0.86	38424 40F62
	0.84 - 0.87	38424 N3113	0.90 - 0.95	38424 10V03	0.89	38424 40F63
	0.87 - 0.90	38424 N3114			0.92	38424 40F64
	0.90 - 0.93	38424 N3115			0.95	38424 40F65
	0.93 - 0.96	38424 N3116			0.98	38424 40F66
					1.01	38424 40F67
					1.04	38424 40F68
					1.07	38424 40F69
					1.10	38424 40F70
					1.13	38424 40F71
					1.16	38424 40F72
					1.19	38424 40F73
					1.22	38424 40F74
					1.25	38424 40F75
					1.28	38424 40F76
					1.31	38424 40F77
				1.34	38424 40F78	
				1.37	38424 40F79	
				1.40	38424 40F80	
				1.43	38424 40F81	
				1.46	38424 40F82	
				1.49	38424 40F83	

## ADJUSTMENT OF DRIVE PINION HEIGHT

### Adjusting washer for adjustment of drive pinion height

Type	R200 (Strengthened), R200V (Strengthened)							
	Thickness mm	Parts number	Thickness mm	Parts number	Thickness mm	Parts number	Thickness mm	Parts number
Adjusting washer	3.09	38154 P6017	3.24	38154 P6022	3.39	38154 P6027	3.54	38154 P6032
	3.12	38154 P6018	3.27	38154 P6023	3.42	38154 P6028	3.57	38154 P6033
	3.15	38154 P6019	3.30	38154 P6024	3.45	38154 P6029	3.60	38154 P6034
	3.18	38154 P6020	3.33	38154 P6025	3.48	38154 P6030	3.63	38154 P6035
	3.21	38154 P6021	3.36	38154 P6026	3.51	38154 P6031	3.66	38154 P6036

# REAR FINAL DRIVE

## ADJUSTMENT OF DRIVE PINION PRE-LOAD

Type	R200 (Strengthened), R200V (Strengthened)	
Drive pinion pre-load	N-m (kg-m)	1.1 - 1.6 (0.11 - 0.17)

### Adjusting washer for adjustment of drive pinion pre-load

Type	R200 (Strengthened), R200V (Strengthened)			
	Thickness mm	Parts number	Thickness mm	Parts number
Adjusting washer	3.81	38125 61001	3.97	38133 61001
	3.83	38126 61001	3.99	38134 61001
	3.85	38127 61001	4.01	38135 61001
	3.87	38128 61001	4.03	38136 61001
	3.89	38129 61001	4.05	38137 61001
	3.91	38130 61001	4.07	38138 61001
	3.93	38131 61001	4.09	38139 61001
	3.95	38132 61001		

### Adjusting spacer for adjustment of drive pinion pre-load

Type	R200 (Strengthened), R200V (Strengthened)	
	Thickness mm	Parts number
Adjusting spacer	45.6	38165 10V05
	45.9	38165 10V06
	46.2	38165 10V07
	46.5	38165 10V00
	46.8	38165 10V01

## ADJUSTMENT OF SIDE BEARING PRE-LOAD

Type	R200 (Strengthened), R200V (Strengthened)	
Side bearing pre-load	N-m (kg-m)	0.3 - 1.4 (0.03 - 0.15)

### Adjusting washer for adjustment of side bearing pre-load

Type	R200 (Strengthened), R200V (Strengthened)			
	Thickness mm	Parts number	Thickness mm	Parts number
Adjusting washer	2.00	38453 N3100	2.35	38453 N3107
	2.05	38453 N3101	2.40	38453 N3108
	2.10	38453 N3102	2.45	38453 N3109
	2.15	38453 N3103	2.50	38453 N3110
	2.20	38453 N3104	2.55	38453 N3111
	2.25	38453 N3105	2.60	38453 N3112
	2.30	38453 N3106	2.65	38453 N3113

## ADJUSTMENT OF TOTAL PRE-LOAD

Type	R200 (Strengthened), R200V (Strengthened)			
Total pre-load with oil seal installed	N-m (kg-m)	1.4 - 3.1 (0.14 - 0.32)		
Drive gear backlash	mm	0.1 - 0.15		
Drive gear backlash	mm	Final gear reduction ratio	4.083, 4.363	0.1 - 0.15
			4.111	0.13 - 0.18

# DRIVE SHAFT

## FRONT

### Z80T70C

Joint type		Final drive side	T70C
		Wheel side	Z80
Amount of grease		Final drive side	110 - 120
		Wheel side	75 - 85
Boot length at installed		Final drive side	95.5 - 97.5
		Wheel side	90.5 - 92.5
Spider assembly (final drive side)	Stamped number	Parts number	Type
	00	39720 51E00	T70C
	01	39720 51E01	
	02	39720 51E02	
	03	39720 51E03	

### Z80T82F

Joint type		Final drive side	T82F
		Wheel side	Z80
Amount of grease		Final drive side	95 - 105
		Wheel side	75 - 85
Boot length at installed		Final drive side	95 - 97
		Wheel side	90.5 - 92.5
Spider assembly (final drive side)	Stamped number	Parts number	Type
	00	39720 10V10	T82F
	01	39720 10V11	
	02	39720 10V12	

## REAR

### T82CT82F

Joint type		Final drive side	T82F
		Wheel side	T82C
Amount of grease		Final drive side	102 - 107
		Wheel side	115 - 125
Boot length at installed		Final drive side	95 - 97
		Wheel side	
Spider assembly (final drive and wheel sides)	Stamped number	Parts number	Type
	00	39720 10V10	T82C T82F
	01	39720 10V11	
	02	39720 10V12	

### Z100D90F

Joint type		Final drive side	D90F
		Wheel side	Z100
Amount of grease		Final drive side	165 - 175
		Wheel side	113 - 123
Boot length at installed		Final drive side	92.9 - 94.9
		Wheel side	96.0 - 98.0

## TIGHTENING TORQUE

Unit: N·m (kg·m)

Front	Drive shaft to side flange (left side)		28 - 37 (2.8 - 3.8)
	Drive shaft nut		236 - 313 (24.0 - 32.0)
Rear	Drive shaft to side flange	T82CT82F	35 - 44 (3.5 - 4.5)
		Z100D90F	64 - 78 (6.5 - 8.0)
	Drive shaft nut		206 - 274 (21.0 - 28.0)



# AXLE & SUSPENSION

## WHEEL ALIGNMENT

Front	Camber		-0°45'±45'
	Caster		6°35'±45'
	King pin inclination		12°50'±45'
	Toe-in	mm	0 to In 2
	Amount of side slip (Reference)	mm	In 5 to Out 5
Rear	Camber		-0°55'±30'
	Toe-in	mm	0 to Out 5.2
	Amount of side slip (Reference)(Only for HICAS)	mm	In 5 to Out 5

## WHEEL BEARING

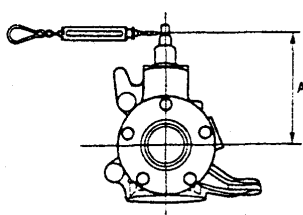
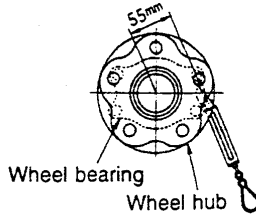
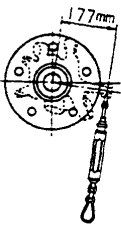
Location	Front axle	Rear axle	
Applied model	2WD	Without SUPER HICAS	With SUPER HICAS
Rotating torque N-m (kg-m)	Less than 2.45 (0.25) (NSK make) Less than 3.33 (0.34) (NTN make)	0.30 - 1.17 (0.03 - 0.12) (NSK make) 0.520 - 1.882 (0.053 - 0.192) (NTN make)	0.520 - 1.882 (0.053 - 0.192)
Spring scale measurement N (kg)	Less than 15.9 (1.63) (NSK make) Less than 21.6 (2.21) (NTN make)	5.0 - 21 (0.5 - 2.2) (NSK make) 2.95 - 10.5 (0.30 - 1.08) (NTN make)	2.95 - 10.5 (0.30 - 1.08)
Spring scale set position	Length "A" mm		
	153		
			
	FAC1161D	RAC0997D	RAC0998D
End play	mm	0	

## BALL JOINT

Oscillating torque	N-m (kg-m)	0.50 - 3.40 (0.05 - 0.35)
Spring scale measurement (at cotter pin hole)	N (kg)	7.95 - 55.3 (0.81 - 5.64)
Sliding torque	N-m (kg-m)	0.50 - 3.40 (0.05 - 0.35)
End play	mm	0

# AXLE & SUSPENSION

## TIGHTENING TORQUE

Unit: N·m (kg·m)

Front	Wheel hub lock nut		206 - 284 (21.0 - 29.0)
	Transverse link to suspension member		108 - 127 (11.0 - 13.0)
	Transverse link to steering knuckle		71 - 86 (7.2 - 8.8)
	Steering knuckle to third link		98.1 - 117 (10.0 - 12.0)
	Third link to upper link (front and rear)		89.0 - 107 (9.0 - 11.0)
	Stabilizer to connecting rod		47 - 51 (4.7 - 5.3)
	Stabilizer connecting rod to mounting bracket		42 - 47 (4.2 - 4.8)
	Stabilizer clamp fixing bolt		108 - 127 (11.0 - 13.0)
	Stabilizer clamp fixing nut		40 - 49 (4.0 - 5.0)
	Shock absorber assembly to third link		89.0 - 107 (9.0 - 11.0)
	Shock absorber assembly to underbody		40 - 53 (4.0 - 5.5)
	Shock absorber piston rod lock nut		18 - 23 (1.8 - 2.4)
Rear	Wheel hub lock nut		206 - 274 (21.0 - 28.0)
	Lower arm to suspension member		78.0 - 98.0 (7.90 - 10.0)
	Lower arm to axle housing		71 - 86 (7.2 - 8.8)
	Lower arm connecting rod		8.9 - 11 (0.9 - 1.2)
	Lateral link to suspension member		69 - 88 (7.0 - 9.0)
	Lateral link to axle housing		78.0 - 98.0 (7.90 - 10.0)
	Front upper link fixing nut		
	Rear upper link	Bolt	77.5 - 98.0 (7.90 - 10.0)
		Nut	69 - 88 (7.0 - 9.0)
	Connecting rod to stabilizer		8.9 - 11 (0.9 - 1.2)
	Stabilizer clamp		44 - 54 (4.4 - 5.6)
	Shock absorber assembly to axle housing	Without SUPER HICAS	99.0 - 117 (10.0 - 12.0)
		With SUPER HICAS	88.3 - 107 (9.0 - 10.0)
	Shock absorber assembly to underbody		16 - 18 (1.6 - 1.9)
	Shock absorber piston rod lock nut		18 - 23 (1.8 - 2.4)

# ROAD WHEEL AND TIRE

## ROAD WHEEL

Wheel type		Aluminum	Steel
Runout limit mm	Lateral	Less than 0.3	Less than 0.8
	Vertical	Less than 0.3	Less than 0.5
Permissible amount of residual imbalance g	Dynamic (measured at lug)	Less than 10 (one side)	
	Static (measured at lug)	Less than 20	
Wheel nut tightening torque N-m (kg-m)		103 - 122 (10.5 - 12.5)	

## TIGHTENING TORQUE

Unit: N-m (kg-m)

Wheel nut	103 - 122 (10.5 - 12.5)
-----------	-------------------------

## TIRE

Tire size	Tire air pressure kPa (kg/cm <sup>2</sup> )	
	Front wheel	Rear wheel
205/60R15 91H	200 (2.0)	200 (2.0)
205/55R16 89V	220 (2.2)	220 (2.2)
205/45ZR17	220 (2.2)	220 (2.2)
T125/70D16	420 (4.2)	420 (4.2)
T125/90D16	420 (4.2)	420 (4.2)
T135/70D17	420 (4.2)	420 (4.2)

GI

EC

AT

FA

BR

RS

HA

EL

SI

# BRAKE

## BRAKING FORCE

Total braking force of rear wheels	More than 10% of axle weight
Variation between right and left of each wheel	Less than 8% of axle weight
Total braking force	More than 50% of vehicle weight at inspected

Note: The braking force when both front wheels are locked up can be considered to meet the total braking force.

## BRAKE PEDAL

Free play (at pedal top surface) mm	3 - 11
Brake pedal height (from dash panel top surface) mm	M/T: 163 - 173 A/T: 170 - 180
Depressed pedal height under force of 490 N (50 kg) (from dash panel top surface) mm	M/T: More than 85 A/T: More than 90
Clearance between the edge of stop lamp switch screw and pedal stopper mm	0.3 - 1.0

## CHECK VALVE

Vacuum leakage [at vacuum of 66.7 kPa (-500 mmHg)]	Within 1.3 kPa (10 mmHg) of vacuum for 15 seconds
--	---

## BRAKE BOOSTER

Vacuum leakage [at vacuum of 66.7 kPa (-500 mmHg)]	Within 3.3 kPa (25 mmHg) of vacuum for 15 seconds
Input rod standard length at installed mm	140

## FRONT DISC BRAKE

Brake type		AD25VB	CL25VD	OPZ25VC
Brake pad	Standard thickness (New) mm	10.0		
	Wear limit of thickness mm	2.0		
Disc rotor	Standard thickness (New) mm	22	26	30
	Wear limit of thickness mm	20	24	28
	Runout limit mm	Less than 0.07		

## REAR DISC BRAKE

Brake type		AD11VC	OPZ11V
Brake pad	Standard thickness (New) mm	9.3	11.5
	Wear limit of thickness mm	2.0	
Disc rotor	Standard thickness (New) mm	16	18
	Wear limit of thickness mm	14	16
	Runout limit mm	Less than 0.07	

## PARKING BRAKE

Type		DS17HD
Brake lining	Standard thickness (New) mm	3.0
	Wear limit of thickness mm	1.5
Drum	Standard inner diameter (New) mm	172 dia.
	Wear limit of inner diameter mm	173 dia.
Operating stroke [under force of 196 N (20 kg)]		5 - 7 notches
Maximum stroke		19 notches
Number of notches when brake warning lamp turns on		Within 1 notch

## TIGHTENING TORQUE

Unit: N·m (kg·m)

Master cylinder fixing nut	12 - 14 (1.2 - 1.5)
Front caliper mounting bolt	152 - 154 (15.5 - 15.8)
Brake tube flare nut	15 - 17 (1.5 - 1.8)

# STEERING

## STEERING WHEEL

Steering wheel end play	mm	0
Steering wheel free play	mm	0 - 35
Amount of steering gear housing movement	mm	Within ±2

## STEERING ANGLE

Inner wheel	42°
Outer wheel	33°

## STEERING COLUMN

Steering column length "L"	mm	610
----------------------------	----	-----

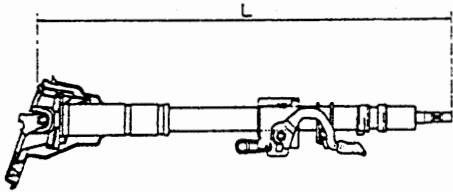

STC0720D

## STEERING LINKAGE

Steering gear type		PR26AD PR26AF PR25J
Tie-rod ball joint outer socket	Oscillating torque N-m (kg-m)	0.30 - 2.94 (0.03 - 0.30)
	Spring scale measurement (at stud bolt hole) N (kg)	6.48 - 64.6 (0.66 - 6.59)
	Sliding torque N-m (kg-m)	0.30 - 2.94 (0.03 - 0.30)
	End play mm	Less than 0.5
Tie-rod ball joint inner socket	Oscillating torque N-m (kg-m)	1.0 - 7.8 (0.1 - 0.8)
	Spring scale measurement (at arrow position in figure below) N (kg)	19.0 - 152 (1.90 - 15.5)
	End play mm	Less than 0.2
Tie-rod length "L"	mm	173.3

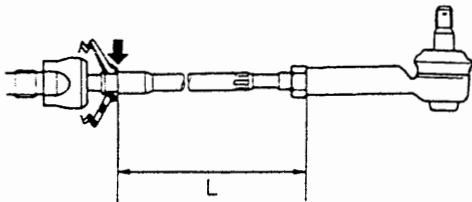

STC0973D

## STEERING GEAR

Steering gear type	PR25J, PR26AD, PR26AF	
Rack neutral position "L"	mm	68.5

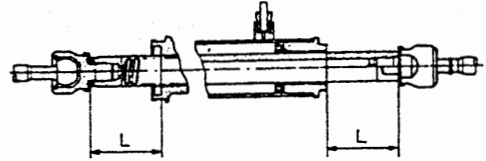

STC0101D

Retainer adjustment	Screw lock nut tightening torque N-m (kg-m)	40 - 58 (4.0 - 6.0)	
	Primary tightening torque N-m (kg-m)	5.0 - 5.8 (0.5 - 0.6)	
	Re-tightening torque after loosening once N-m (kg-m)	5.0 - 5.8 (0.5 - 0.6)	
	Adjusting screw back-off	60° - 80°	
Rack sliding force	Range within ±11.5 mm from neutral position (at power ON)	Area mean value N (kg)	187 - 245 (19.0 - 25.0)
		Range of variations N (kg)	Less than 98.0 (10.0)
	Full range (at power OFF)	Peak value N (kg)	Less than 294 (30.0)
		Range of variations N (kg)	Less than 147 (15.0)

## OIL PUMP

Maximum oil pump pressure MPa (kg/cm <sup>2</sup> )	8.82 <sup>+0.4</sup> <sub>-0.2</sub> (90) (Without HICAS) 7.84 <sup>+0.4</sup> <sub>-0.2</sub> (80) (With HICAS)
--	---

## STEERING FLUID

Fluid capacity	ℓ	Approx. 1.0
----------------	---	-------------

## TIGHTENING TORQUE

Unit: N-m (kg-m)

Steering wheel nut	30 - 39 (3.0 - 4.0)	
Steering gear to suspension member	89 - 91 (9.0 - 9.3)	
Steering gear to steering column	24 - 29 (2.4 - 3.0)	
Outer socket to steering knuckle	30 - 39 (3.0 - 4.0)	
Tie-rod lock nut	79 - 98 (8.0 - 10.0)	
Oil pump fixing bolt	Large	32 - 42 (3.2 - 4.3)
	Small	14 - 17 (1.4 - 1.8)
Hydraulic tube (high pressure side) to oil pump	50 - 68 (5.0 - 7.0)	
Hydraulic tube to steering gear	High pressure side	15 - 24 (1.5 - 2.5)
	Low pressure side	28 - 39 (2.8 - 4.0)

GI  
EC  
AT  
BR  
ST  
RS  
HA  
EL  
SD

# SUPER HICAS

## POWER CYLINDER

Power cylinder ball joint	Oscillating torque N-m (kg-m)	0.98 - 7.80 (0.1 - 0.8)
	End play mm	0

## POWER CYLINDER LOWER LINK

Power cylinder lower link length	mm	290.4±1.0
----------------------------------	----	-----------

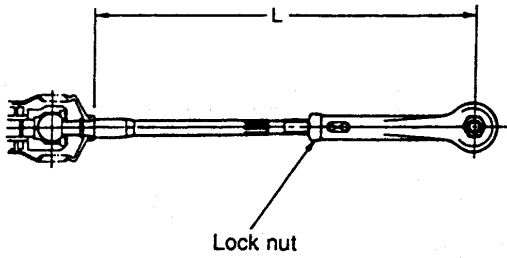

STC0240D

Clearance at power cylinder stroke	mm	3.6±0.1
------------------------------------	----	---------

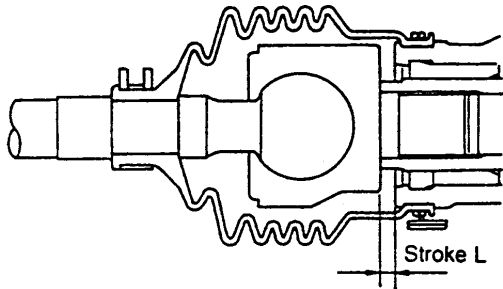

STC0602D

## TIGHTENING TORQUE

Unit: N-m (kg-m)

HICAS actuator assembly fixing bolt	84.4 - 107 (8.60 - 11.0)
Outer link to axle housing	46 - 59 (4.6 - 6.1)